

Dental Unit
GALLANT AUTONOME PRO (model: AU/AL)

OPERATING MANUEL

VERSION 1_ENG_2022



GALIT

Ukraine 47711, Ternopil region, Baykivtsi village, 15 Kvitnya str., 6E
tel:+420775471378

E-mail export@galit.te.ua,

www.galit-dental.com

List of revisions of changes

Reasons for the changes

Rev	Date of revision	Reason of the changes

List of the change pages

Page № / Revision	Information about document changes	Page №	Information about document changes

Make sure you are using the latest version of the document.

Contact your distributor or manufacturer for the latest version.

Introduction

When purchasing the unit, make sure that there is a stamp of the trading company, the date of sale and the signature of the seller in section 11 of this manual for operation and in the coupons for warranty repairs. Check the completeness of the dental unit according to section 2.4 of this operating manual.

REMEMBER! In the absence of appropriate markings, the warranty period starts from the date of manufacture of the dental unit.

These operating instructions are an integral part of your new dental unit. Always keep it close to the unit so you or your technician can access it quickly and easily.

Read this operating manual and make sure you understand it completely before you start working with the dental unit. This operating manual cannot cover all aspects of use, but it can help to avoid mistakes when using your dental unit.

The information contained in this operating manual is correct and new at the time of printing. The information in the operating instructions is provided to facilitate operation of the dental unit. Always follow the recommendations, they will help make the operation of your dental unit economical and efficient. Our dental units are constantly improved, their characteristics are improved, the design is updated, therefore the drawings and designations in this operating manual may slightly differ from your dental unit.



Translation of the instructions was made with appropriate competence and in good faith. However, we cannot take responsibility for translation errors. In case of inaccuracies in the translation, the Ukrainian version of the Installation Instructions and Operating Instructions is considered as the main one.

If any damage or problems occur when using the dental unit, contact the service department of the company that sold the unit to you.

If some repairs are necessary, use only original spare parts to ensure that your dental unit works efficiently throughout its lifetime.

All products are tested and guaranteed for 12 months from the date of sale. This guarantee is provided to all customers who have fulfilled contractual and administrative obligations, installed and use the dental unit in accordance with the operating instructions. Under this warranty, the MANUFACTURER will repair or replace free of charge all components that are found to be defective due to the manufacturer's fault or fail during the warranty period.

The MANUFACTURER's technical assistance service is the only authority to determine whether a malfunction is covered by the warranty. The guarantee does not cover the labour costs of the employees of the Technical Assistance Service, which must be reimbursed. The warranty does not take into account the MANUFACTURER's responsibility for direct or indirect loss or damage caused to people or objects as a result of improper use or maintenance of the dental unit, and the warranty applies only to materials and installation. Furthermore, the warranty does not cover the costs incurred by the MANUFACTURER's personnel for transportation, inspection, replacement or re-installation, unless the malfunctions are the result of defects in materials or assembly. All costs will be deducted from the user.

Equipment Classification	
	<p>The following classification methods correspond to IEC/EN 60601-1:</p> <ul style="list-style-type: none"> • According to the directive on medical devices 93/42/EEC, the dental unit corresponds to Class II a. • In accordance with the requirements of IEC/EN 60601-1, the dental unit is Class I equipment. • According to CISPR 11, the dental unit is ISM of group 1, Class B equipment.
 Marking UA.TR.099	National sign of compliance with technical regulations with the identification number of the designated conformity assessment body.
Marking CE	
	<p>This product meets the regulatory requirements of the European Union Directive 93/42/EEC on medical devices.</p> <p>Compliance with this Directive is evidenced by the CE sticker on the product.</p> <p>Location of the CE sticker is indicated in section 1.1 of the operating manual.</p>



The dental unit does not belong to measuring equipment for medical purposes and does not require periodic metrological attestation.

Відповідність міжнародним стандартам / Compliance with the international standards		
Стандарт/Standard	Українська назва/Ukrainian name	English title
93/42/EEC	Директива 93/42/ЄЕС від 14.06.1993 Щодо питання медичного обладнання	COUNCIL DIRECTIVE 93/42/EEC of 14 June 1993 concerning medical devices
EN 60601-1	Вироби медичні електричні. Частина 1. Загальні вимоги щодо безпеки та основних технічних характеристик	Medical electrical equipment. General requirements for basic safety and essential performance
EN 60601 -1-2	Вироби медичні електричні. Частина 1-2. Загальні вимоги щодо безпеки та основних робочих характеристик. Додатковий стандарт. Електромагнітна сумісність. Вимоги та випробування	Medical Electrical Equipment – Part 1-2: General Requirements for Basic Safety and Essential Performance – Collateral Standard: Electromagnetic Disturbances – Requirements and Test.
IEC 80601-2-60	Обладнання медичне електричне. Частина 2-60.	Medical electrical equipment - Part 2-60: Particular requirements for basic safety and essential performance of dental equipment
EN ISO 7494-1	Стоматологія. Установки стоматологічні. Частина 1. Загальні вимоги та методи випробування	Dentistry - Dental units - Part 1: General requirements and test methods
EN ISO 7494-2	Стоматологія. Установки стоматологічні. Частина 2. Водопостачання та подавання повітря	Dentistry - Dental units - Part 2: Air, water, suction and wastewater systems
ISO 10993-1	Біологічне оцінювання медичних виробів. Частина 1. Оцінювання та тестування в рамках процесу управління ризиками.	Biological evaluation of medical devices - Part 1: Evaluation and testing within a risk management process

The European Representative Office

The European representative office is registered at the address:

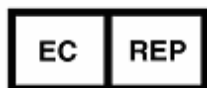

Company Name: **Galdent CZ s.r.o.**
 Address: K.Vapence 448, 41503 Teplice, Czech Republic
 Company number: 103510996
 Easy number: 00007069449932
 National identification number: 28741536
 Registration number: C 29946

Certificates

No.: CE 703906

Service representatives in Europe (phone numbers, address):

1.1 Identification name plate

An identification name plate with the inscription of general data is placed on the adapter between the patient chair and the dental unit .



Fig.1.1.1 Identification plate for dental units with upper delivery of instruments



Fig.1.1.2 Identification plate for dental units with lower delivery of instruments

Serial Number (SN): **XXXX MM YY** **XXXX** - № of the dental unit
MM – month of manufacture
YY – year of manufacture

When requesting information, services, or replacement parts, always indicate the model, type, and serial number of your dental unit. This information is indicated on the identification name plate and in the warranty coupon for the dental unit.

Symbol

	Manufacturer.
	This product meets the regulatory requirements of the European Union Directive 93/42/EEC on medical devices.
	ATTENTION! Pay special attention to items marked with this sign. These paragraphs describe actions that, if not followed, could result in personal injury or danger to life, or damage to the equipment, if this operating manual is not followed.
	Working part of type B*. Protection class I. <i>* type of user part of dental instruments (B or BF) see operating instructions for the instrument</i>
	BE SURE TO REFER TO THE INSTRUCTIONS OR OPERATING MANUAL FOR THIS PRODUCT BEFORE USING THE PRODUCT <i>(Instructions for use, operating manuals, accompanying documents).</i>
	Manufacturing country. Year of manufacture.
	Disposal of electronic equipment in accordance with Directive 2002/96/EC.
	This product is a medical product.
	An authorized representative who distributes the medical product in the region.
REF	Number according to Catalogue

1.2 Content

Introduction.....	3
1.1 Identification name plate.....	5
1.2 Content.....	6
1.3 Safety measures.....	8
2 Description of the dental unit.....	11
2.1 Product information.....	11
2.2 Description of the component parts of the dental unit.....	12
2.3 Doctor Table versions.....	13
2.4 Technical Characteristics.....	14
2.5 Set of Delivery.....	15
3 Dental unit Switching On.....	Помилка! Закладку не визначено.
3.1 Checking the dental unit before starting work.....	Помилка! Закладку не визначено.
4 Pressure switch unit.....	17
4.1 Electromagnetic compressor motor starter.....	17
5 Doctor table.....	18
5.1 Doctor table control panel.....	19
5.2 Adjustment of operating modes of instruments on the doctor table.....	20
5.2.1 Dental syringe.....	22
5.2.1.1 Dental syringe LUZZANI.....	22
5.2.1 3-way dental syringe DCI.....	23
5.2.2 Pneumatic turbine.....	24
5.2.3 Electric micromotor.....	26
5.2.3.1 Electric micromotor BIEN AIR.....	26
5.2.3.2 Electric micromotor NSK.....	27
5.2.4 Piezoelectric scaler.....	28
5.2.5 Curing lamp.....	32
5.2.5 Coagulator.....	33
5.3 Version of dental unit "GALLANT AUTONOME PRO" with ENDO option.....	34
5.3.1 Adjusting the frequency of rotation of the micromotor at the II - IV workplace in normal mode.....	36
5.3.2 Adjusting the rotation frequency of the micromotor in the ENDO mode.....	38
5.3.3 Adjusting the torque of the micromotor at the III workplace in the ENDO mode.....	40
6 Assistant table.....	41
6.1 Assistant table control panel.....	41
6.2 Adjusting the working modes of instruments on the assistant table.....	42
6.3 Programming the working positions of the dental chair.....	42
7 Water Unit.....	43
7.1 Functions of filling the cup and rinsing the cuspidor bowl.....	43
7.2 Programming the time of filling the cup and rinsing the cuspidor bowl.....	44
7.3 Memorization of the "spray" and "illumination" modes for I-IV instruments.....	46
7.4 Adjustment of water-air mixture (SPRAY).....	47
7.5 Distilled Water System.....	48
7.6. Adjustment of tension of the instrument delivery levers.....	49
8 Maintenance.....	50
8.1 Recommended products for care, cleaning and disinfection.....	50
8.2 Care of instruments.....	53
8.3 Lamp (dental).....	54
8.3.1 Lamp (dental) MAIA.....	54
8.3.2 Lamp (dental) EVA.....	55
8.4 Cleaning the cuspidor filter.....	57
8.5 Cleaning the exhaust air filter of pneumatic outlets.....	57
8.6 Filling container for filling the cup and rinsing the cuspidor bowl.....	58
8.7 Replacing the bacterial filter.....	59
8.8 Replacement of the autonomous container for secretions.....	60
8.8.1 Operation with filling the cup and rinsing the cuspidor bowl.....	60
8.9 Separator.....	61
8.9.1 Separator "CS1".....	61
8.9.2 Maintenance of separator CS1 of the aspiration system with a collector of solid particles.....	62
8.9.3 Separator of "Cattani" company.....	63
8.9.4 Separator "CAS1".....	64
8.10 Draining condensate from the tank.....	66

8.11 Maintenance of the aspiration system	67
8.11.1 Cleaning the filter of the aspiration unit	69
8.12 Thermal switch of the fan of the compressor compartment	70
8.13 Replacement of fuse links	71
8.14 Recommended maintenance frequency	74
8.15 Technical malfunctions and methods of their elimination	74
8.16 Disinfection. Flushing the internal channels of the hoses of the dental unit	75
9 Electromagnetic compatibility (EMC) (MEK 60601-1-2)	77
10 Disposal	81
Appendix A1. Overall dimensions of the autonomous unit " GALLANT AUTONOME (model: AU)"	82
Appendix A2. Overall dimensions of the autonomous unit "GALLANT AUTONOME (model: AL)".	83
Appendix B. Checking the parameters of dental equipment.....	84
Appendix B. Dental unit "GALLANT AUTONOME PRO". Pneumatic diagram.....	86
11. General Warranty Conditions	

1.3 Safety Measures

In terms of safety, the product meets the requirements of IEC/EN 60601-1 and is Class I Type B* equipment.

* type of user part of dental instruments (B or BF) see operating manual for the instrument.

- Installation of the dental unit must be performed by personnel who have the right to do so and in accordance with the "Installation Instructions".
- The dental unit must be connected to a network with protective earthing.
- Operation of dental equipment (dental chair, lamp, dental unit) without reliable grounding is strictly prohibited.
- It is strictly forbidden to carry out troubleshooting in the dental unit connected to the power network.



- It is prohibited to use the device to persons who have not read this operating manual in detail.
- Follow the operating manual for proper use.
- Do not use the device if there are signs of damage. In case of malfunctions, call an authorized technician.
- Replace damaged parts and components only with original spare parts approved for replacement by the company GALIT.
- Always turn off the main power switch of the dental unit after finishing work.

General Safety Instructions

Intended use	<p>This dental unit is used for therapy, diagnosis and treatment of teeth by trained personnel.</p> <p>This product is not intended for use in explosive atmospheres.</p>
Installation performed by the user on site	<p>Installation of the dental unit must be performed according to the requirements of the manufacturer. A detailed description is presented in the installation instructions.</p>
Care and repair	<p>As a manufacturer of dental equipment, in order to ensure the operational reliability and safety of the product, we attach great importance to the fact that maintenance and repairs are performed only by us or by personnel who have received from us the exclusive right to do so, and in the event of failure of parts that affect the safety of work product, they were replaced only with original spare parts.</p> <p>When carrying out such work, it is recommended to obtain from the manufacturer a document indicating the type and scope of work, if necessary, with information about the change of nominal parameters or working range, and with the date, information about the manufacturer, and signature.</p>
Changes to the product	<p>Changes to the product that may affect the safety of the user, patient or other persons are strictly prohibited in accordance with the law!</p> <p>To ensure operational reliability and safety, this product may be operated only with original components manufactured by Galit or with components from other manufacturers authorized by Galit. The user bears all responsibility for the use of unauthorized components (parts).</p> <p>All products connected to the dental unit must comply with the current regulations:</p> <p>IEC 60950 for data processing and transmission systems (for example, PCs), as well as IEC 60601-1 for medical and technical equipment.</p>
Combination with other devices	<p>When connecting the unit to other equipment (e.g. a PC), as well as changing the electrical system, it is the user's responsibility to ensure that the requirements of IEC 60601-1-1 (Regulations for the safe operation of medical electrical systems) regarding patient safety are fully complied with, service personnel and the environment.</p> <p>If in doubt, consult the manufacturer of the dental unit.</p>
Electromagnetic compatibility (EMC)	<p>Dental unit "GALLANT OMNIPRATIQUE" meets requirements of IEC60601-1-2 standard.</p> <p>Dental unit "GALLANT OMNIPRATIQUE" meets requirements of electromagnetic compatibility group 1 class B according to DSTU CISPR 11.</p> <ul style="list-style-type: none">• Group 1 – medical equipment that intentionally generates or uses radio frequency energy with conductive communication necessary for the internal functioning of the equipment itself.• Equipment of B class – is the equipment suitable for domestic use and units that are directly connected to the low-voltage power supply network that supplies buildings used for domestic purposes. <p>Class B equipment must comply with Class B standards.</p>

Electromagnetic compatibility (EMC)	<p>Medical electrical equipment must meet all safety requirements for EMC.</p> <p>The equipment must be installed and operated in accordance with the instructions given in the document "Electromagnetic Compatibility (EMC) (MEK 60601-1-2)".</p> <p>Portable and mobile RF communication devices can affect electro-medical equipment. It is necessary to prohibit the use of radio telephones on the territory of clinics and medical practices.</p>
Quality of water/air supplied	<p>Air and water supply must meet the requirements specified in the instructions. Use only clean water.</p>
Requirements for water characteristics	<p>The user of the dental facility is responsible for the quality of the water supplied and, if necessary, must take alternative measures to comply with water requirements.</p>
Suction system	<p>The suction of aluminium oxides or other metals from the jet devices through the separation automation and amalgam separator built into the dental unit is prohibited! This leads to extreme wear and clogging of suction and drainage channels.</p> <p>When using metal-oxide jet devices, a separate suction device must be used. Dental units with central wet suction are fundamentally suitable for suction of the above-mentioned materials. Strictly follow the instructions of the manufacturer of your suction system. There are still no restrictions for the use of jet devices in combination with "GALLANT OMNIPRATIQUE" dental units. But at the end of the work, it is necessary to ensure sufficient washing with water.</p>
Dental chair	<p>Consider the maximum load on the dental chair, which is equal to 135 kg according to EN ISO 6875 (tested with a four-fold safety margin).</p>
Maintenance of the dental unit	<p>In order to ensure the normal functioning of the unit, it is necessary to carry out regular maintenance and preventive work at the established frequency to ensure operational reliability and safety of work.</p> <p>In order to ensure the operational safety and suitability of the dental unit, to prevent damage caused by natural wear and tear, it is necessary to regularly inspect the installation by employees of the technical support company. In addition, safety control must be performed. Please contact the manufacturer's service center for a maintenance proposal.</p>
Disassembly and reassembly	<p>When disassembling and reassembling the product, you must follow the instructions given in the installation instructions to ensure the operability and stability of the product.</p>
Утилізація 	<p>According to directive 2002/96/EC, to prevent environmental pollution and injury during disposal, please follow the disposal laws.</p> <p>Disposal recommendations are described in the Disposal section.</p>

2 Description of the Dental Unit

The dental unit "GALLANT Autonome PRO" is a complex medical product, which consists of the main elements: patient chair, doctor table, assistant table, water unit, operating lamp, foot control.

Functionally, the following operations can be performed on the "GALLANT Autonome PRO" dental unit:

- adjustment of the rotation frequency of the micromotor from 3,700 to 42,000 rpm. in normal mode and from 550 rpm up to 2900 rpm. in ENDO mode;
- creation of rotating motion of a pneumatic turbine with a rotation frequency of up to 310,000 rpm;
- supply of liquid from the "distilled water" system to the multifunctional dental syringe;
- filling a cup;
- rinsing the cuspidor bowl;
- control of the ejector saliva aspirator;
- turning on and off the lamp;
- adjustment of scaler power at vibration frequency in the range (22-30) kHz.

Upon request, the Manufacturer will provide the necessary wiring diagrams, component specifications, setup instructions, and other information necessary for Service Personnel to replace those parts identified by the Manufacturer as Serviceable.

2.1 Product Information

Intended use

The dental unit "GALLANT Autonome PRO" (hereinafter referred to as the unit) is intended for the provision of dental care in polyclinics, hospitals and other medical facilities.

Installation in medical facilities: During development and manufacture of the dental unit, all special requirements for medical products were taken into account. When installing equipment in medical facilities during mechanical and electrical installation, it is necessary to comply with requirements of **EEC Directive 93/42** on medical devices, **standards IEC 60601-1, IEC 60601-1-1, IEC 60601-1-2**.

Inappropriate use

Any other use of the product, not provided for in this operating manual, is considered improper use. The manufacturer is not responsible for any damage caused as a result. All risks in this case are borne by the user.

2.2 Description of the Dental Unit Component Parts

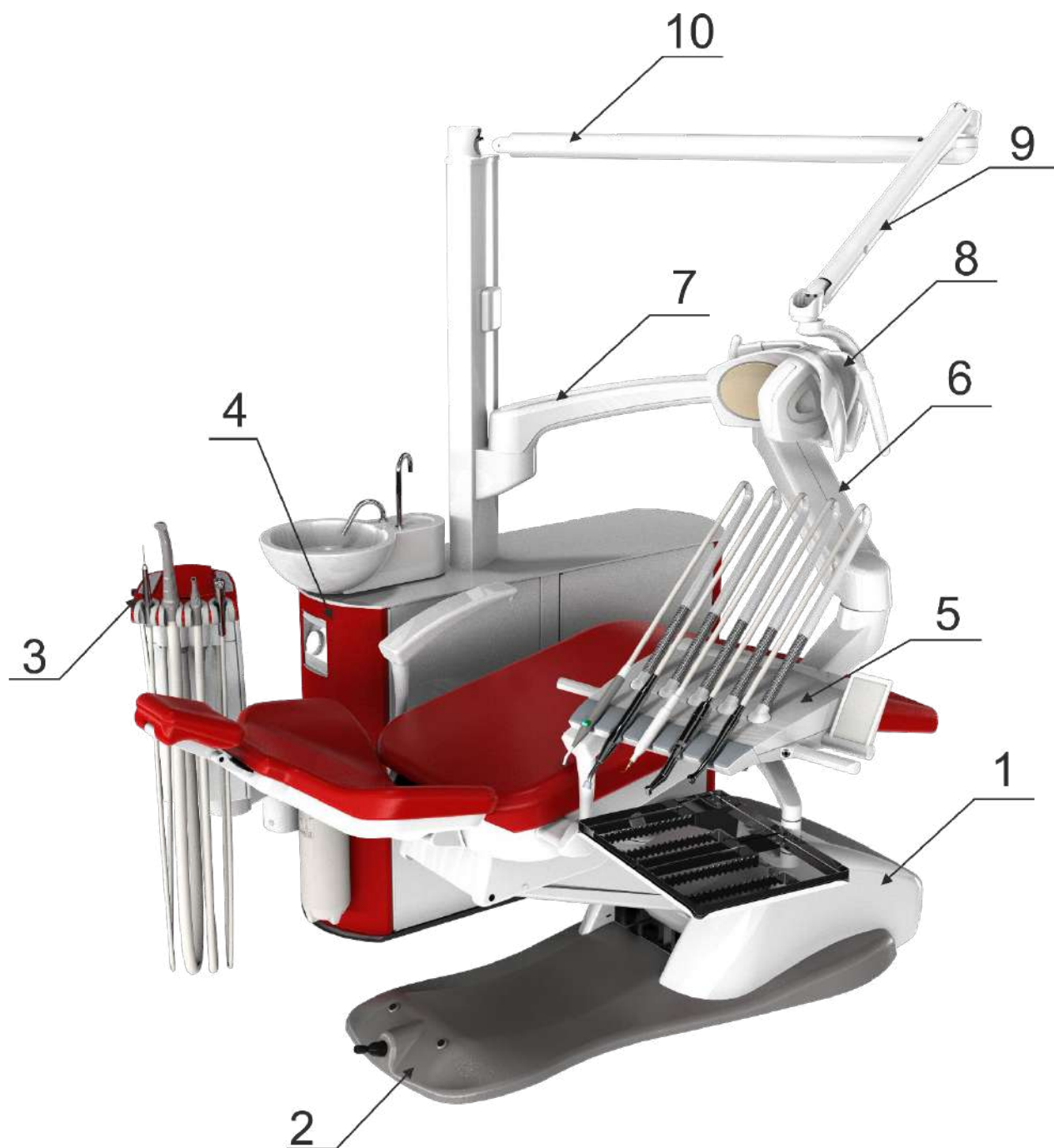

Nº	Name
1	Dental chair
2	Foot control to control chair
3	Assistant table
4	Water unit
5	Doctor table
6	Pantograph arm
7	Doctor table rotary arm
8	Dental lamp
9	Pantograph arm of dental lamp
10	Rotary arm of dental lamp

Figure 2.2.1

2.3 Doctor Table versions

The doctor instrument table on the rotary arm with upper (Figure 2.3.1.) or lower (Figure 2.3.2.) delivery of hoses includes:

- 3-way syringe;
- turbine pneumatic outlet with illumination;
- electric micromotor;
- negatoscope;
- control panel to control dental unit and patient chair.



“GALLANT U”
with upper delivery of instrument hoses
(Figure 2.3.1.).

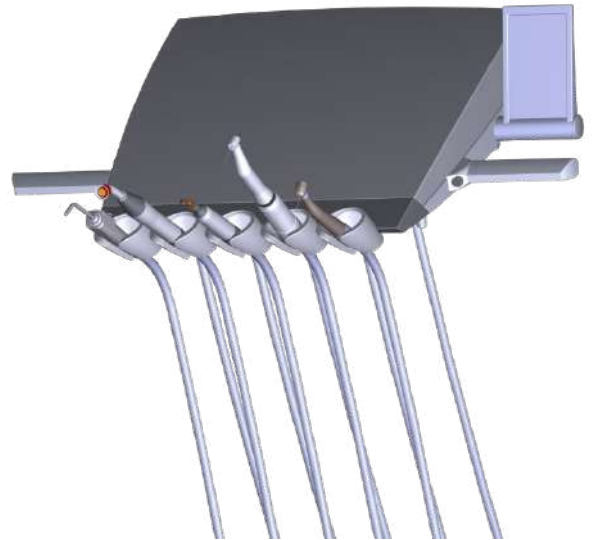



“GALLANT L”
with lower delivery of instrument hoses
(Figure 2.3.2.).

2.4 Technical Characteristics

Supply voltage	220 V, 50 Hz
Water consumption	No more than 60 ml/min. From the distilled water system *
Compressed air supply (5 bar)	60 l/min.
Compressed air mains pressure	3,5-5,5 kg/cm ²
Maximum current consumption	До 14А
Average power consumption:	
doctor table	75 VA
compressor DK-50 DS	370 VA
suction aggregate V250	415 VA
chair	850 VA
lamp	90 VA
in standby mode	20 VA
in operating mode	200 VA
Maximum power consumption	1350 VA
Maximum load on the instrument table	2kg
Noise level when the compressor is on, dB**	59
Noise level when the aggregate is turned on, dB**	60-62
Noise level when the compressor and aggregate are on, dB **	60-63
Compressor working pressure, bar	7,5
Tank volume, l	3
Maximum suction flow, l/min	1100
Suction maximum level (hPa)	127
Noise level of suction unit, dB	≤64
Container for clean water, l	4
Container for secretions, l	5
Weight	160 - 175 kg*

*Note depending on the configuration of the unit.

** according to EN 60601-1 (Rev3) standard. According to EN ISO 1680 Guide for the measurement of noise generated by rotating electrical machines; measured in a soundproof room. Higher values can be found in soundproof rooms.

Conditions of transportation and storage	Ambient temperature:	-40°C – +70°C
	Relative air humidity:	10% – 100%
	Atmospheric pressure:	500 –1060 hPa
Operating conditions	Ambient temperature:	+10°C – + 40°C
	Relative air humidity:	30% – 75%
	Atmospheric pressure:	700–1060 hPa
Protection class	Protection class I product	
Degree of protection against electric shock:	Type B user part	
Degree of protection against water ingress according to IEC 60529 (dental unit)	IPX0 Normal product (no protection)	
Degree of protection against water ingress according to IEC 60529 (foot control)	IPX1	
Operating mode	Continuous mode with repeated short-term load according to work of the dentist.	
	Stationary installed product.	
Year of manufacture	 (on the identification name plate of the dental unit)	20XX

2.5 Set of Delivery

1	Dental unit "GALLANT AUTONOME PRO"	SN:	1 pc.	<input type="checkbox"/>
2	Operating Manual to "GALLANT AUTONOME PRO" dental unit		1 pc.	<input type="checkbox"/>
3	Installation Manual to "GALLANT AUTONOME PRO" dental unit		1 pc.	<input type="checkbox"/>
4	Kit of mounting parts (located in the box of mounting and spare parts)		1 pc.	<input type="checkbox"/>
5	Patient Chair		1 pc.	<input type="checkbox"/>
6	Operating Manual to Patient Chair		1 pc.	<input type="checkbox"/>
7	Lamp EDI/MAIA/ALYA/EVA		1 pc.	<input type="checkbox"/>
8	Operating Manual to Lamp		1pc.	<input type="checkbox"/>
9	Foot Control		1 pc.	<input type="checkbox"/>
10	Accessories that are part of dental unit with relevant instructions for operation. <i>Specify the model.</i>	SN:		
	1) micromotor		1 pc.	<input type="checkbox"/>
	2) micromotor		1 pc.	<input type="checkbox"/>
	3) micromotor		1 pc.	<input type="checkbox"/>
	4) syringe		1 pc.	<input type="checkbox"/>
	5) syringe		1 pc.	<input type="checkbox"/>
	6) curing lamp		1 pc.	<input type="checkbox"/>
	7) scaler		1 pc.	<input type="checkbox"/>
	8) separator		1 pc.	<input type="checkbox"/>
	9) water unit heater		1 pc.	<input type="checkbox"/>
	10) doctor table heater		1 pc.	<input type="checkbox"/>
	11) monitor		1 pc.	<input type="checkbox"/>
	12) camera		1 pc.	<input type="checkbox"/>
	13) cuspidor valve		1 pc.	<input type="checkbox"/>
	14) compressor		1 pc.	<input type="checkbox"/>
	15) suction aggregate		1 pc.	<input type="checkbox"/>
	16)			<input type="checkbox"/>
	17)			<input type="checkbox"/>
	18)			<input type="checkbox"/>
	19)			<input type="checkbox"/>
	20)			<input type="checkbox"/>
11	Set of certificates and licences		1 pc.	<input type="checkbox"/>



3 Dental Unit Switching On

1. Connect the plug of the power cable of the unit to a power outlet (~220 V, 50 Hz) with a grounding contact.
2. Turn on the protective circuit breaker FA1 by pressing ON button. Turn on the machine at the first startup of the unit.
3. Turn on the main switch of the unit. The light indicator of this switch signals the supply voltage.



Рисунок 3.1

3.1 Checking the dental unit before starting operation

1. Check the lamp operation.
2. Check operation of cup filling and bowl rinsing:
 - when briefly pressing the **button to fill the cup**  on the doctor table control panel (Figure 5.1.1) or on the assistant table control panel (for versions with the assistant control panel) - water enters the cup during 3 sec. If you press the control panel button again earlier than 3 sec. , supply of water to the cup stops;
 - when briefly pressing the **button to rinse bowl**  on the doctor table control panel (Figure 5.1.1) or on the assistant table control panel (for versions with the assistant control panel) – the bowl is being rinsing during (10-12) seconds. If you press the control panel button again earlier than (10-12) seconds, the bowl rinsing stops.
3. Check operation of the saliva extractor: The saliva extractor starts working after removing it from the holder.
4. Check operation of the instruments of the doctor table (see section 5 of the Instructions): for pneumatic instruments and instruments with cooling, adjust additional working pressures and flows of water-air cooling mixtures.
5. Check operation of the high-speed suction system (for versions with a high-speed suction system): the suction aggregate must start after removing the suction hose from the holder and stop after inserting the hose into the assistant control panel holder.

4 Pressure Switch Unit

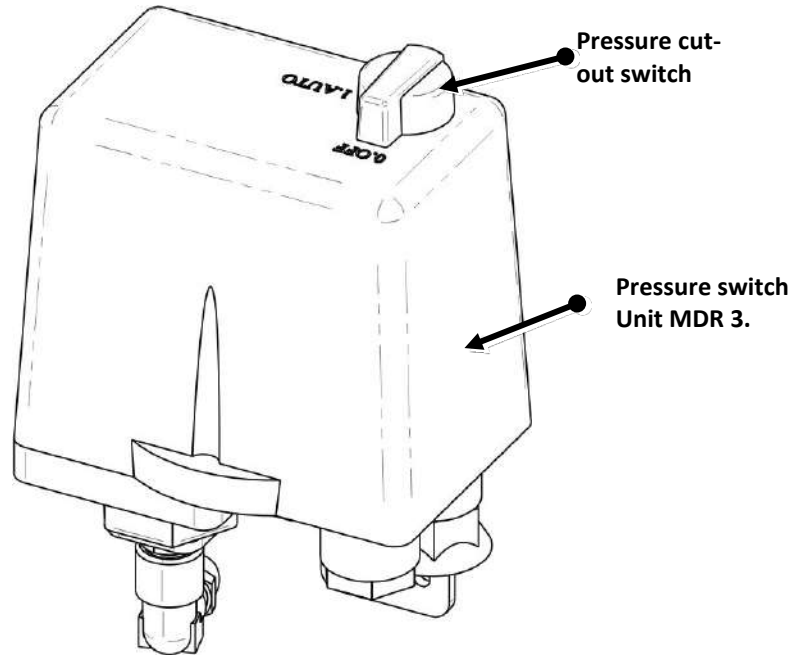

Figure 4.1.

4.1 Electromagnetic compressor motor starter

The electromagnetic starter **KM1** is designed to turn on or off the electrical equipment of the entire installation. The element switches the mains voltage 220V, 50Hz to the main electrical component of the unit, such as compressor, suction aggregate, water unit controller, doctor table and assistant table. The control winding of the starter is activated when the main switch of the unit, located on the front panel of the water unit, is switched.

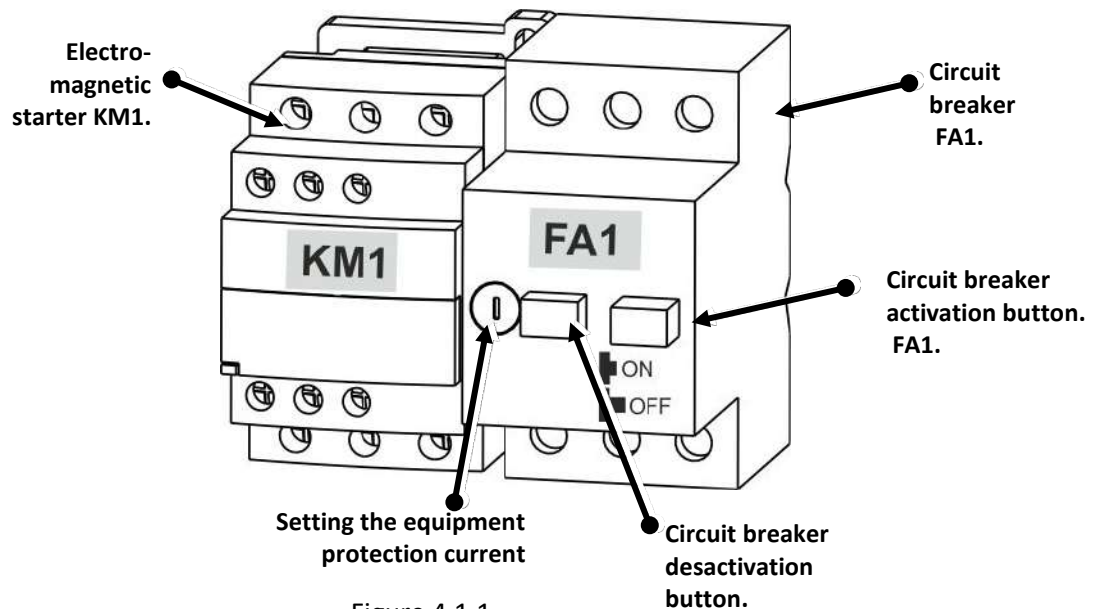

Figure 4.1.1

KM1 - electromagnetic compressor motor starter.

FA1 – circuit breaker. Set to the protection current -8A.

Protective circuit breaker **FA1** performs the function of protecting the electrical equipment of the unit in overload mode or in emergency mode, as well as protecting both the unit and external networks from possible consequences of emergency operation.



If the FA1 circuit breaker is activated, the service technician must find and eliminate the malfunction of the equipment. It is strictly forbidden for the user to start the unit forcibly until troubleshooting!

5 Doctor Table

Depending on the order, the doctor instrument table on the rotary arm can be with upper or lower delivery of hoses with the possibility of installing 5 different instruments. In the standard version, the doctor table is equipped with:

- DCI 3-way dental syringe;
- electric micromotor MC2 (BIEN AIR);
- one turbine pneumatic outlet for connecting the turbine handpiece;
- control panel to control operation of instruments and functions of the patient chair;
- negatoscope.

5.1 Doctor Table Control Panel

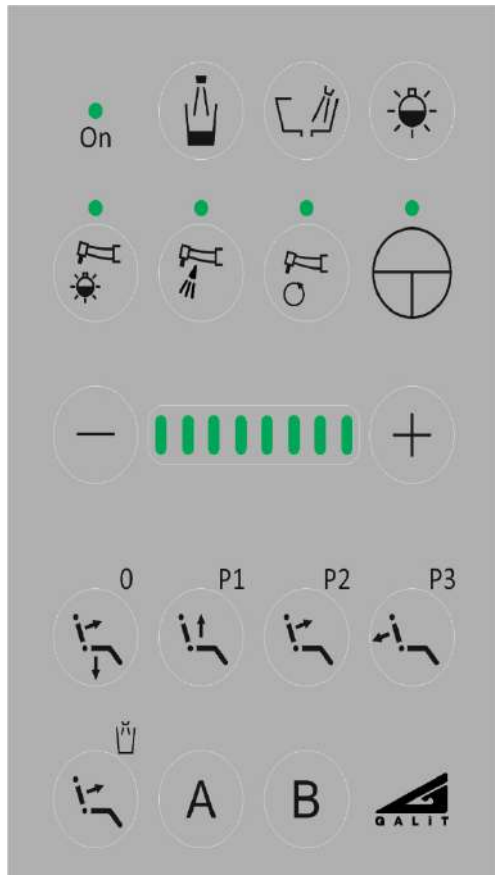

Figure 5.1.1 Doctor table control panel
GALLANT

On

The table power-on indicator.
The indicator lights up - the table is on.



The button for filling the cup with cold water (not used).



Cuspidor bowl rinsing button (not used).



Light On/Off button (not used).



On/Off device illumination button
Indicator is On – illumination is On.



Water On/Off button in online mode for cooling devices. The indicator is on - cooling is on.



The button to change direction of rotation of the electric micromotor.
Indicator is On – reverse is On.



ENDO mode On/Off button
Indicator is On – ENDO mode is ON. Button is not illuminated – Normal mode.



Decrease.



Indicators of gradation of power level or rotation frequency
(increase goes from right to left).



Increase

*** Note. When working with the scaler, the mentioned instruments power level is controlled by buttons**



Quick pressing - the chair moves into position «0».

Holding down the button - the seat of the chair moves down.



Patient chair is moving up/down.



The backrest is moving up.



The backrest is moving down.



A quick press - the backrest of the chair moves up to the position for rinsing the oral cavity.



The same as



The same as

5.2 Adjustment of operating modes of instruments on doctor table



Section 5.2. "Adjusting the operating modes of instruments in the doctor table" describes only general rules for using operating instruments and general rules for adjusting these instruments.

Detailed instructions for operation and maintenance of operating instruments, as well as the delivery set, are presented in the operating documentation for these instruments

The instruments, except for the dental syringe and some models of curing lamps, are controlled by a pneumatic foot control through a microcontroller board, which is located in the doctor table.

The microcontroller controls the switching on / off of the instruments, the rotating movement of the micromotor in normal mode and ENDO mode, supply of spray and illumination, operation of the diathermocoagulator and scaler, if there are such in the doctor table.

The internal software of the microcontroller is oriented to any customer with an arbitrary set of instruments and their placement on the doctor table. In particular, micromotors can be placed on the second, third or fourth workplace with the maximum permissible supply voltage from the range of 24V, 30V. It is also possible to place scalers from different manufacturers with different requirements for output power regulation, etc.

Correspondence between the internal software of the microcontroller and the set of instruments and their placement is established when ordering a dental unit and is performed only at the "Galit" enterprise.

All operational final settings of the power level, rotation frequency, and indications performed by the doctor during work are stored in the microcontroller's memory. When the power is switched on again, all the last settings are saved.

The system of priority selection of instruments prevents the simultaneous operation of several instruments. Control is carried out by the first removed instrument

The pneumatic pedal makes it possible to start pneumatic instruments and adjust their speed.



ATTENTION! Before removing the instruments from the doctor table, make sure that the instrument control pedal is not pressed - otherwise the instrument will start operating automatically and can cause personnel injury.

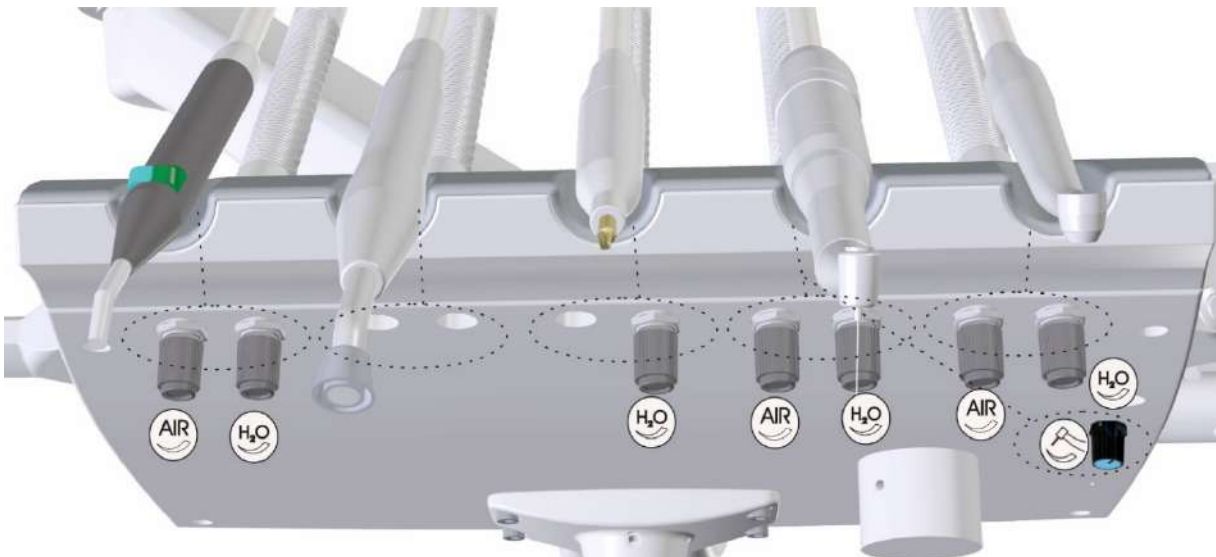











Figure 5.2.1. Placement of the controls of working instruments on the doctor table upper delivery of hoses

Adjustment of the operating modes of the instruments is carried out with a help of the controls, which are located under the doctor table (below). Each instrument has its own adjustment block, which is located under the corresponding instrument. Operational adjustments are on the same axis as the instrument.

Table 5.2.1 shows options for adjustment blocks of operating instruments.

Table 5.2.1

Marking	Block of adjustment of electric micromotor	Block of adjustment of pneumatic outlet	Block of adjustment of scaler	Block of adjustment of curing lamp	Block of adjustment of 3-way syringe
					
	X	operating pressure (2,5 ±0,3 bar) *	X	X	X
	air flow in the water-air cooling mixture	air flow in the water-air cooling mixture	X	X	Air flow
	water flow in the water-air cooling mixture	water flow in the water-air cooling mixture	water flow for cooling		Water flow
	X	X	power of the scaler is regulated by buttons  , on the doctor table control panel	X	X
ENDO/ PERIO/ SCALING	X	X	operating mode switch	X	X

*** Note:**

operating pressure for the pneumatic turbine is set on the manometer according to the technical requirements for a specific model of the turbine.

5.2.1 Dental Syringe

5.2.1.1 Dental Syringe LUZZANI



Figure 5.2.1.1.1.

1. Procedure for the syringe operation:

- Take off the syringe from the instrument table;
- To get **water**, press the left button on the syringe body. To get **air**, press the right button on the syringe body. To obtain **water-air mixture (spray)**, press two buttons on the syringe body at the same time;
- To change the angle of the nose inclination, turn the nose of the syringe to the required position.

2. The mode of operation of the dental syringe is a repeatedly - short-term mode.

3. Syringe maintenance:

Clean the nose of the syringe with a mandrel.

Carry out **Disinfection** of the external surfaces, buttons, body, with a soft cloth moistened with a disinfectant solution.

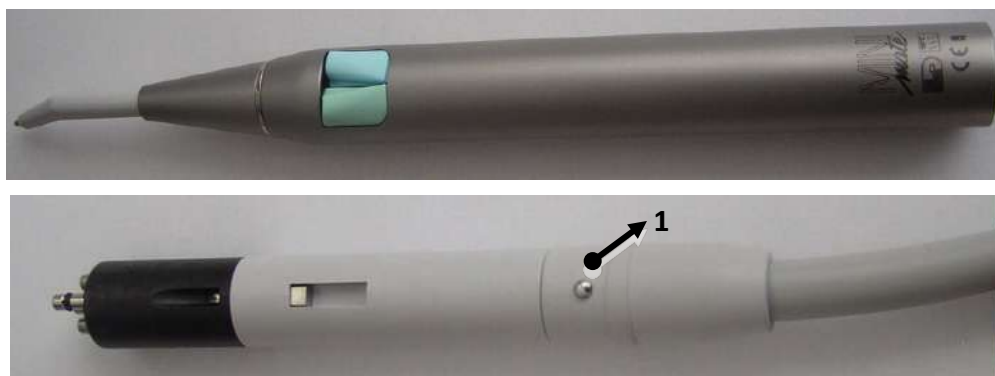

Figure 5.2.1.1.2.

Sterilization: press the button (position 1 Figure 5.2.1.1.2.), remove the tip with the body without disassembling the syringe nose, place in an autoclave at a temperature of +1350C, sterilize for 20 minutes.

Technical characteristics of the syringe:

Max. Water inlet pressure	Bar	2,5
Max. Air inlet pressure	Bar	4,5
Air flow rate	NI / min	10
Water flow rate	cm2 /min	110



Detailed instructions for the operation and maintenance of the dental syringe and the delivery set are provided in the operational documentation for the syringe.

5.2.1 3-Way Dental Syringe DCI

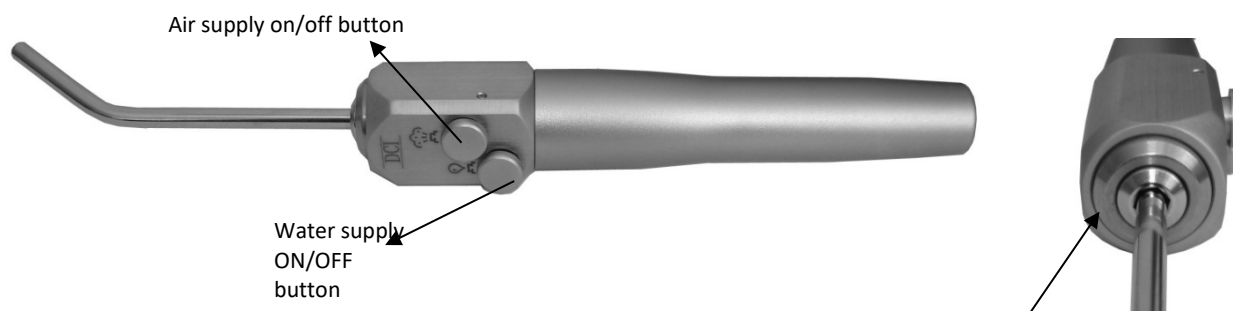



Figure 5.2.1.1.1

1. Procedure of the syringe operation:

- Take off the syringe from the instrument table;

- To get **water**, press the left button  on the syringe body.

To get **air**, press the right button  on the syringe body.

To get **water-air mixture (spray)**, press two buttons on the syringe body at the same time;

- To change the angle of the nose inclination, turn the nose of the syringe to the required position.

2. The mode of operation of the dental syringe is a repeatedly - short-term mode.

3. Syringe maintenance:

Clean the nose of the syringe with a mandrel.

Carry out **Disinfection** of the external surfaces, buttons, body, with a soft cloth moistened with a disinfectant solution.

Sterilization of the syringe nose should be carried out in an autoclave at a temperature of +135°C for 20 minutes. To remove and then install the nose in the syringe body, you need to press the ring according to figure 5.2.1.1.



Detailed instructions for the operation and maintenance of the dental syringe and the delivery set are provided in the operational documentation for the syringe.

5.2.2 Pneumatic Turbine

1. Connection of pneumatic outlet

The pneumatic outlet of the unit has a four-channel hose with a connection to a turbine, pneumatic motor or pneumatic scaler.

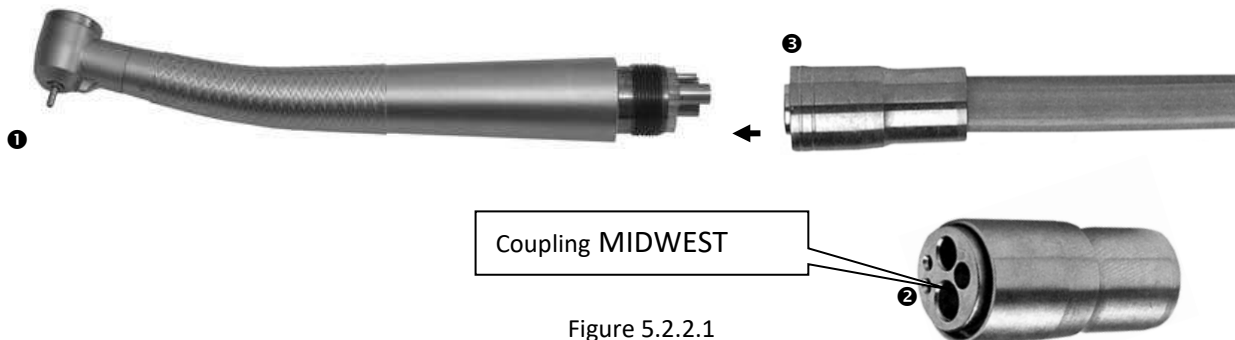

2. Preparation for work:

Connect the turbine ① to the pneumatic outlet ② and screw the nut ③.



CAUTION!

It is strictly forbidden to switch on the turbine without an instrument installed in the handpiece!

3. Procedure of the turbine operation:

- Take off the turbine from the doctor table and press the foot control;
- Set operating pressure by the control  located on bottom of the doctor table opposite the pneumatic outlet according to the doctor table pressure gauge index or with help of control pressure gauge REF 1600242-001 "Bien Air".



ATTENTION!

Operating pressure of the pneumatic outlet is set separately for each specific model of the pneumatic turbine according to its technical requirements.

- Set proportion of water-air mixture for cooling with controls  and  on bottom of the doctor table opposite the pneumatic outlet.

4. Procedure for adjusting pressure of the pneumatic turbine according to the control manometer.

- Take off the instrument;
- Connect the control manometer according Figure 5.2.2.2 or Figure 5.2.2.3;
- Press the pneumatic foot control to the stop, which corresponds to the maximum speed of rotation of the turbine **(for a pneumatic foot control)**;
- Set the foot control lever to the extreme right position, which corresponds to the maximum speed of the turbine **(for a multi-function foot control)**;
- Set needed pressure by control  on bottom of the doctor table opposite the pneumatic outlet.

5. Mode of Operation.

Turbine operation mode in accordance with the operational documentation.

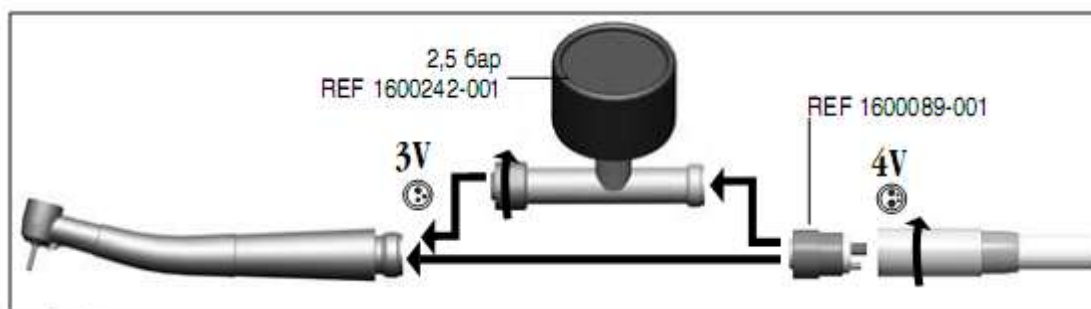

Figure 5.2.2.2

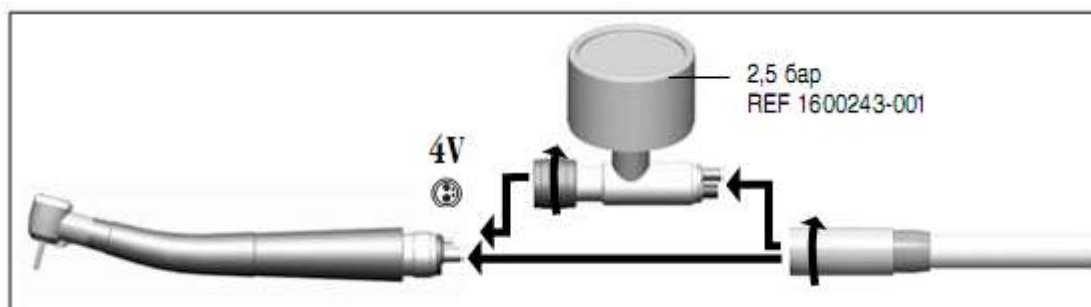

Figure 5.2.2.3

Figure 5.2.2.2. and Figure 5.2.2.3. — Connection diagrams of the control manometer.

Note. The measurement error of the manometer of the doctor table due to the length of the hose does not exceed 0.3 bar.

6. Turbine maintenance:



WARNING! The durability of the turbine tips depends on the fulfillment of the lubrication requirements, as well as on compliance with the recommended operating pressure.

Detailed instructions for the operation and maintenance of the pneumatic turbine and the delivery set are given in the operational documentation for the turbine.

5.2.3 Electric Micromotor

5.2.3.1 Electric Micromotor BIEN AIR



ATTENTION! It is strictly prohibited to switch on the electric micromotor without an instrument installed in the handpiece!



1. To start the micromotor, take off the instrument from the holder and press the foot control. The micromotor will rotate clockwise.

Speed of rotation of the micromotor is set by the speed control  of block of adjustment of electric micromotor (Table 5.2.1.) or the slider of the multi-functional foot control.

2. To reverse direction of rotation, release the foot control and then press the reverse activation button  on the doctor table control panel.



ATTENTION! Direction of rotation is changed only when the instrument comes to a complete stop.

3. In micromotors with water-air mixture supply for cooling, proportion of water-air mixture is set by controls  and  of the electrical micromotor adjustment block.

For micromotors with light, switch on the light by means of the button for switching on the light of the instruments  on the doctor table control panel.

To ensure reliable operation of the micromotor, use only dry compressed air.

4. Cooling of the micromotor.

Cooling of the micromotor is set at the manufacturer enterprise. When replacing the micromotor, the cooling is adjusted and checked. The check is carried out using an air flow meter (flow meter for motor, N107.24.08, order code 1600307-001, "Bien Air", Switzerland).



Detailed instructions for the operation and maintenance of the electric micromotor and the delivery set are given in the operational documentation for the micromotor.

Micromotors of company **BIEN AIR**, models **MC2** and **MC3** have ENDO function.

5.2.3.2 Electric Micromotor NSK





ATTENTION! It is strictly forbidden to switch on the electric micromotor without an instrument installed in the handpiece!

1 To start the micromotor, remove the instrument from the holder and press the foot control. The micromotor will rotate clockwise. The speed of rotation of the micromotor is set by the speed regulator  of the electrical motor adjustment block (Table 5.2.1.) or by the multifunctional foot control slider.

2 To change the direction of rotation, release the pedal and then press the reverse button  on the doctor table control panel.



ATTENTION! Direction of rotation is changed only when the instrument comes to a complete stop.

3 In micromotors with water-air mixture supply for cooling, the proportion of water-air mixture is set by regulators  and  of the electrical micromotor adjustment block.

For micromotors with lighting - switch on the light with the button for switching on the light of the instruments  on the doctor table control panel.

To ensure reliable operation of the micromotor, use only dry compressed air.

4 **Cleaning**

Manual: Rinse the external surface of the micromotor in running water (<38°C, demineralized water is recommended).

Disinfection

Manual: Wipe the outer surface of the micromotor with a cleaning or disinfecting solution.

Lubrication

NSK surgical micromotors are maintenance-free. Do not lubricate the micromotors.

Sterilization

The micromotor can be repeatedly sterilized in an autoclave at a maximum temperature of 135°C (together with the cap for autoclaving and the cover of the micromotor).

Table 5.2.3.2.1 Technical Specifications.

Motor type	NLX nano	NLX plus	M40XS
Maximum power	19V/5A	25V/5A	24V/5A
Speed	1.000-40.000 rpm/min	100-40.000 rpm/min	60-40.000 rpm/min
Torque	max. 3,4 N·cm	max. 4,0 N·cm	max. 3,4 N·cm
Overall dimensions	70mm x 22mm	77mm x 22mm	91mm x 21mm
Water spray	>65 ml/min	>65 ml/min	>65 ml/min



Detailed instructions for the operation and maintenance of the electric micromotor and the delivery set are given in the operational documentation for the micromotor.

5.2.4 Piezoelectric scaler

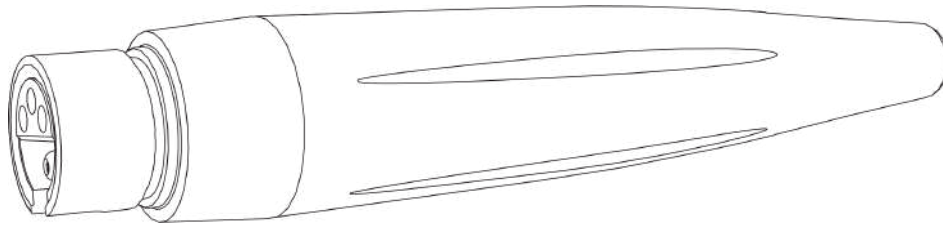

Scaler handpiece

Figure 5.2.4.1

ATTENTION! Do not disconnect the handpiece or handpiece hose while the unit is on.



ATTENTION! The scaler unit does not require additional maintenance, but the components (handpiece cable, tip, files, etc.) should be checked before and after work to detect any damage or insulation defects. Eliminate all malfunctions before starting work.

ATTENTION! The vents of the dental unit must be kept clean to ensure optimal working conditions for the piezoelectric scaler.

1. Preparation for work:

- wear safety glasses and gloves;
- pull out the handpiece, torque wrench and inserts;
- screw the insert into the handpiece, first by hand, and then with a torque wrench (Figure 5.2.4.2 and Figure 5.2.4.3);

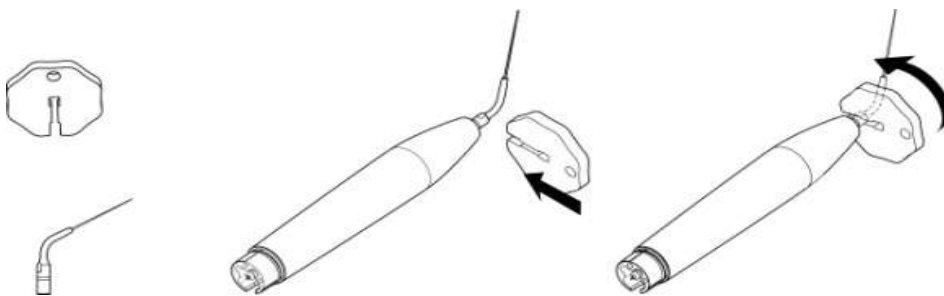

Figure 5.2.4.2

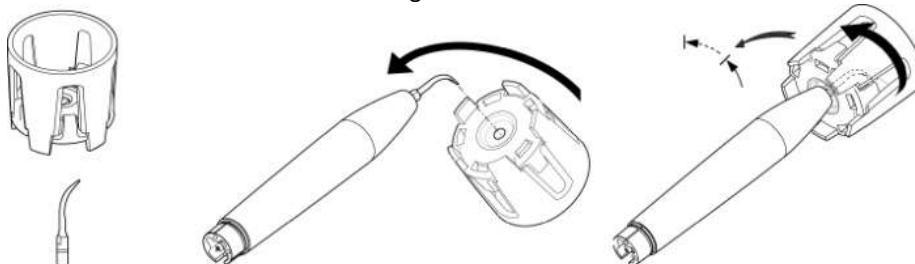

Figure 5.2.4.3



Attention! The handpiece or file must be securely fastened in the holder without excessive pressure. Do not use a flat wrench to secure the handpiece or file as this may damage the handpiece, insert or file.

- connect the handpiece to the hose (Figure 5.2.4.4), when doing so:
 - it is forbidden to rotate the handpiece connector relative to the hose;
 - it is forbidden to wind the hose of the handpiece on medical devices;
 - it is necessary to make sure that the hose does not twist and that no one steps on it;
 - ensure that when performing dental procedures, the hose is in the access zone and is not excessively stretched;
 - make sure that there are no traces of moisture at the junction of the handpiece and the hose;

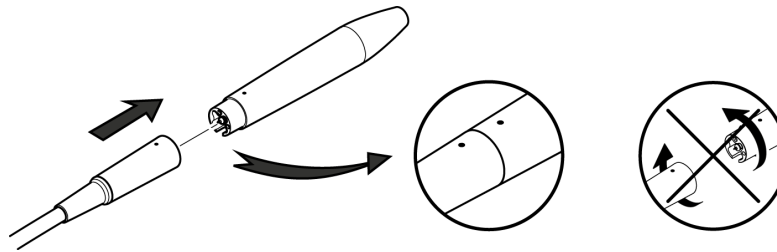

Figure 5.2.4.4

To increase the efficiency of the gasket and eliminate leakage, lubricate the gasket of the irrigation system, which is located on the back side of the handpiece on the metal axis, with a silicone paste. It is not recommended to use a spray for lubricating dental instruments.

- take the handpiece of the scaler in your hand and switch on the device;
- check the operation parameters of the irrigation system;

Irrigation may not be used if the following conditions are met:

- the scaler insert is intended for use without irrigation;
- additional devices are used to improve visibility (microscope or magnifying glass);
- work is done in four hands (doctor + assistant);
- place of intervention is always in the field of vision, which reduces risks of overheating;
- any manipulation should last no more than 1 minute;
- local irrigation is used;
- air drying is carried out.



ATTENTION! Doctor must constantly monitor the process - the lack of irrigation should not create risks for the patient.

2. Intended use:

- take off the scaler from the doctor table;

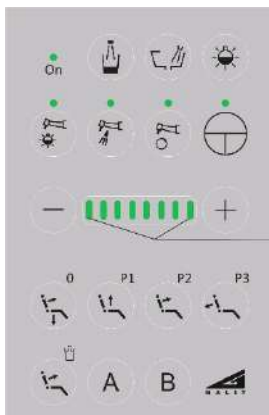





Figure 5.2.4.5

- select the necessary scaler operation mode (PERIO/SCALING) on the control panel of the doctor table (Figure 5.2.4.5). (Inserts or files for the scaler must be selected according to the mode of operation of the scaler).

- by buttons  ,  on the doctor table control panel set a required power for the selected operation;

- if none of the power indicators on the doctor table control panel lights up, the scaler is ready to work in **PERIO** mode;

- **I-VIII indicators** determine the power range for the mode **SCALING** (Figure 5.2.4.5);

- if necessary, adjust with a knob  intensity of water supply (irrigation) for the instrument;
- press the foot control.

ATTENTION! During start of the scaler at the moment of pressing the foot control, it is strictly forbidden to apply any effort to the handpiece of the scaler. Failure to comply with this requirement may result in damage to the handpiece.



ATTENTION! The doctor must hold the active part of the device - the handpiece - in his hand throughout the duration of the medical procedure.

3. Cleaning, disinfection and sterilization of the handpiece, inserts and files:

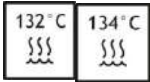

- components and handpieces must be cleaned, disinfected and sterilized before each use;

- during cleaning and disinfection operations, the device must be switched off;
- do not immerse the scaler handpiece in water;
- avoid using cleaning and disinfecting agents containing abrasive cleaning agents and flammable components;
- do not spray the cleaning agent directly on the medical device. **Do not wipe contacts.**

4. Cleaning of the irrigation system:

After installation and before starting use, at the end of the working day or if the scaler has not been used for a long time, it is necessary to clean the irrigation system. To do this, switch on the scaler at the minimum power, but with the maximum use of the irrigation spray for 2 minutes.



Be sure to read the operating documentation provided by the scaler manufacturer before starting work, which contains detailed instructions for operation and maintenance, cleaning, disinfection and sterilization of the device.



ATTENTION! The scaler can contain ENDO mode.

To ensure operation of the ENDO mode; a three-position switch is installed in the dental unit.





Рисунок 5.2.4.6

- select a necessary mode of operation of the scaler (**PERIO/ENDO/SCALING**) on the control panel of doctor table (Figure 5.2.4.6). (Inserts or files for the scaler must be chosen according to the mode of operation of the scaler).

- by buttons  ,  on the doctor table control panel set a needed power for the selected operation;
- *if none of the power indicators* on the doctor table control panel lights up, the scaler is ready to work in **PERIO** mode;
- *I-II indicators* determine power range for **ENDO** mode;
- *III-VIII indicators* determine power range for **SCALING** mode (Figure 5.2.4.6);

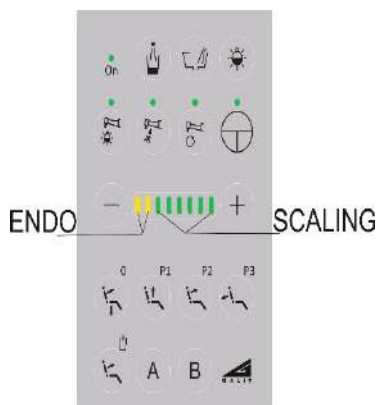
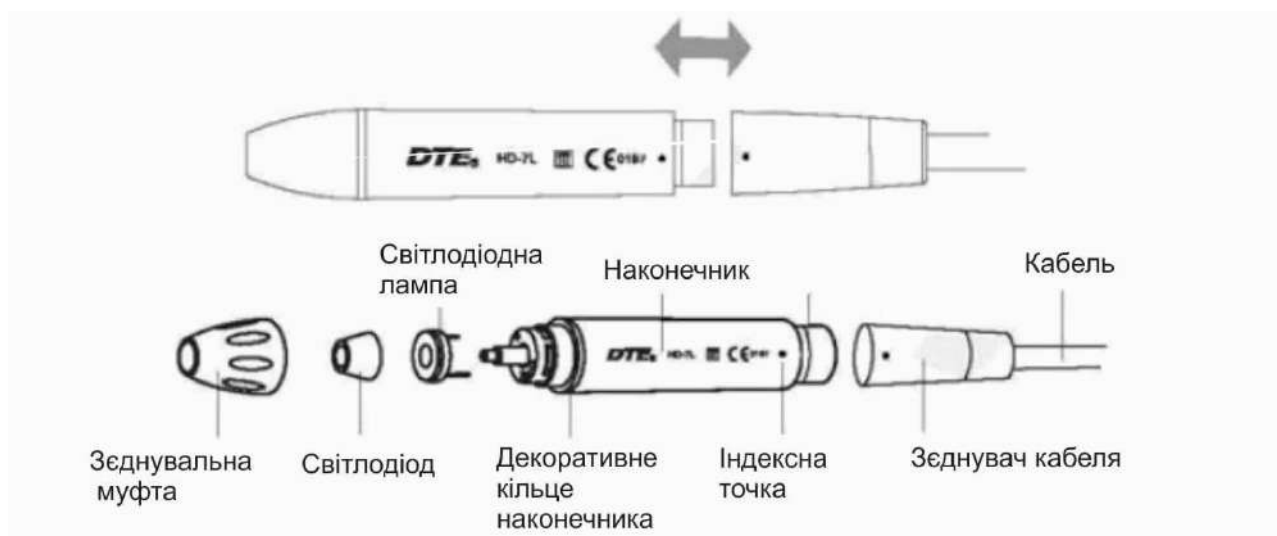
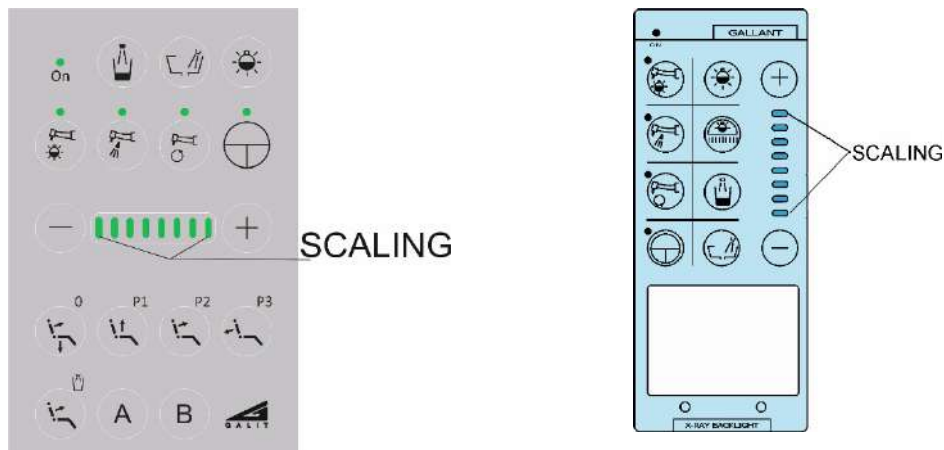

Figure 5.2.4.7 – structure of the LED scaler

Adjustment of the scaler power.

The maximum possible power of the scaler is selected on the control panel.



Multifunction foot control.

The slider on the multi-function foot control adjusts power of the scaler operating mode in the range specified on the control panel.

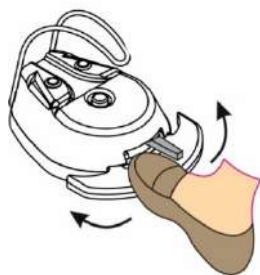

Pneumatic foot control.

The potentiometer located on the doctor table regulates power of the scaler in the range specified on the control panel.

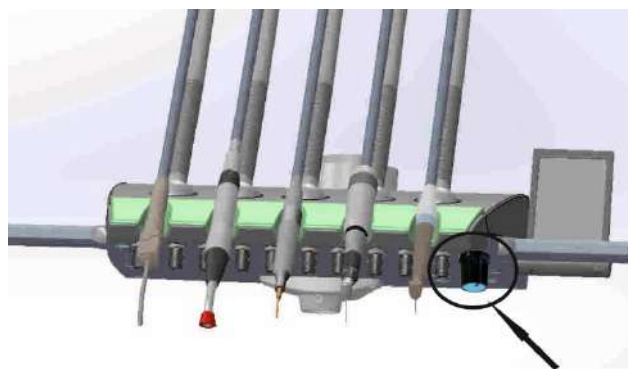

5.2.5 Curing Lamp

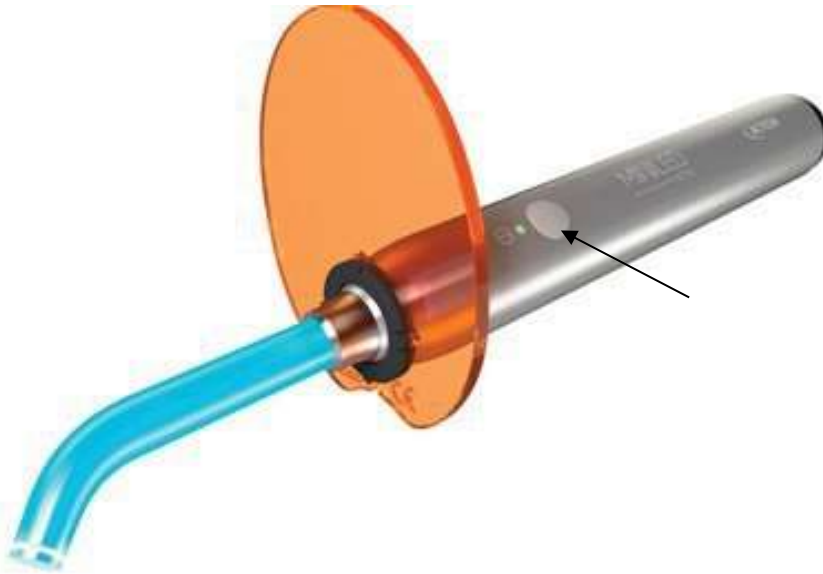

Figc.5.2.5.1. Curing Lamp

To start work, it is necessary to take off the lamp from the holder.

- The curing lamp is turned on and off by pressing the button on the lamp body.
- The lamp switches off if it is not used for 3 minutes. Press On/Off button to start a new cycle.
- The polymerization cycle can be stopped at any time by pressing On/Off button. The lamp switches off if it is not used for 3 minutes. Press On/Off button to start a new cycle.



- The patient and doctor must use special protective glasses.
- Do not expose people with high sensitivity to light to the lamp.
- Do not direct the beam into the eyes.
- The device may interfere with sensitive devices.
- Do not allow composite residue to stick to the optical fibre.
- Do not use the device in a flammable atmosphere.

Recommendations for disinfection and sterilization.

- All work on disinfection and sterilization should be carried out only when the lamp is switched off.
- Never spray any liquid directly on the equipment
- Before starting work, the fibre and the light hood must be cleaned and sterile.
- Do not use abrasive products and products with aggressive impurities.



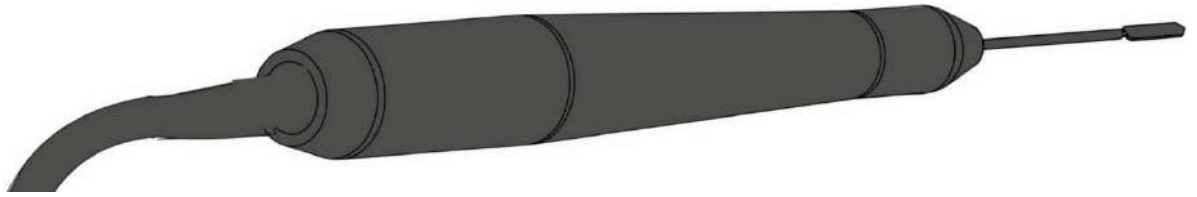

Detailed instructions for operation and maintenance, cleaning, disinfection and sterilization are provided in the operating documentation for curing lamps.

5.2.5 Coagulator



Coagulator operation procedure:

1. Placing coagulator on the doctor table

- Select a required mode of operation with the "COAGULATION/CUTTING" ("КОАГУЛЯЦІЯ/РІЗАННЯ") switch, which is located at the bottom of the doctor table.
- Take off the coagulator from the doctor table.
- Press the foot control.
- By buttons  ,  on the doctor table set the required power for the selected gradation "CUTTING" or "COAGULATION". If there are no buttons on the control panel of doctor table, then set the power with the regulator at the bottom of the doctor table, which is on the same axis as the instrument.



ATTENTION! Do not touch metal objects with the cutting element while the coagulator is working. This may cause the coagulator to malfunction.

2. . Placing the coagulator on the assistant table

- Select the required mode of operation with the "COAGULATION/CUTTING" ("КОАГУЛЯЦІЯ/РІЗАННЯ") switch, which is located at the bottom of the assistant table.
- Take off the coagulator from the assistant table.
- Press the foot control.
- Set the required power with the regulator located on the bottom of the assistant table.



Detailed instructions on the operation and maintenance of the coagulator and the delivery set are provided in the operating documentation for the coagulator.

5.3 Version of “GALLANT AUTONOME PRO” dental unit with ENDO option

Dental unit “GALLANT AUTONOME PRO” with ENDO option has more advanced functionality compared to other versions and is intended, first of all, for work in the field of endodontics.

The following functions are additional (to the main ones in the standard version):

- 1) smooth and stepwise adjustment of frequency of rotation of the micromotor in normal mode.
The maximum value of the rotation frequency by gradations for this mode is given in table 5.3.1;
- 2) smooth and stepwise adjustment of frequency of rotation of the micromotor in the ENDO mode.
The maximum value of the rotation frequency by gradations for this mode is given in table 5.3.1;

TABLE 5.3.1. Measurement of the maximum rotation frequency of the micromotor MC2, "Bien Air", in the nominal mode and in the ENDO mode.

Gradation	Revolutions per minute, $\pm 20\%$ approximate	
	Normal mode	ENDO mode
0	-	550*
I	3700	870*
II	8700	1200*
III	14300	1450*
IV	19700	1630*
V	25050	2100*
VI	30700	2250*
VII	36200	2500*
VIII	42000	2900*

* **Note** Reference data.

- 1) operative selection of torque of forward motion, at which the micromotor stops and switches to reverse motion. It is possible to choose one of eight fixed torque values according to Table 5.3.2. This function can be used only in ENDO mode;

Table 5.3.2 Selection of the maximum torque for collector micromotors MC2, ISOLITE, MC3 “Bien Air” in ENDO mode.

Gradation	Torque, N·cm
I	0,3
II	0,6
III	0,9
IV	1,2
V	1,5
VI	1,8
VII	2,1
VIII	2,3

- 2) presence of positive feedback in the micromotor control circuit. The control scheme is built on the basis of a digital pulse width modulator (PWM), which allows you to maintain the frequency rotation unchanged when increasing / decreasing the load;
- 3) 8-stage adjustment of the output power of the piezoelectric scaler and (or) diathermocoagulator;
- 4) illumination of instruments with a delay on switching off (8÷10) sec;
- 5) memorization of all final settings of rotation frequency, torque, power level when power is switched off;
- 6) visual display of the established modes of the dental unit as a whole, as well as indication of gradations of rotation frequency, torque and power level;
- 7) sound confirmation of pressing a button on the control panel;
- 8) automatic zeroing in the event of failure of the display on the doctor's unit remote control or failure of the doctor table controller.

5.3.1 Adjusting the frequency of micromotor rotation at II - IV workplace in normal mode

1. Switch on the power of the dental unit according to location of the main power switch of the unit. At the same time, the normal operating mode is set on the doctor table (see Figure 4.3.1.1).

2. Take off the micromotor from the II - IV workplace of the doctor table.

3. By means of buttons \oplus and \ominus the doctor table control panel set a maximum speed of the micromotor.

Button \oplus increases the rotation frequency, and button \ominus decreases the rotation frequency.

Each indicator of doctor table displays a certain gradation and corresponds to the specified frequency of rotation of the micromotor.

For example, I-gradation – one indicator is on - revolutions of the micromotor ~ 3700 rpm.

VIII-gradation – eight indicators are on - revolutions of the micromotor ~ 42000 rpm.

4.a – for pneumatic foot control

Set a knob of one or the both potentiometers  of doctor table to the extreme right position corresponding to maximum rotation frequency of the micromotor and smoothly change the rotation frequency from zero to the maximum value for this value gradation.

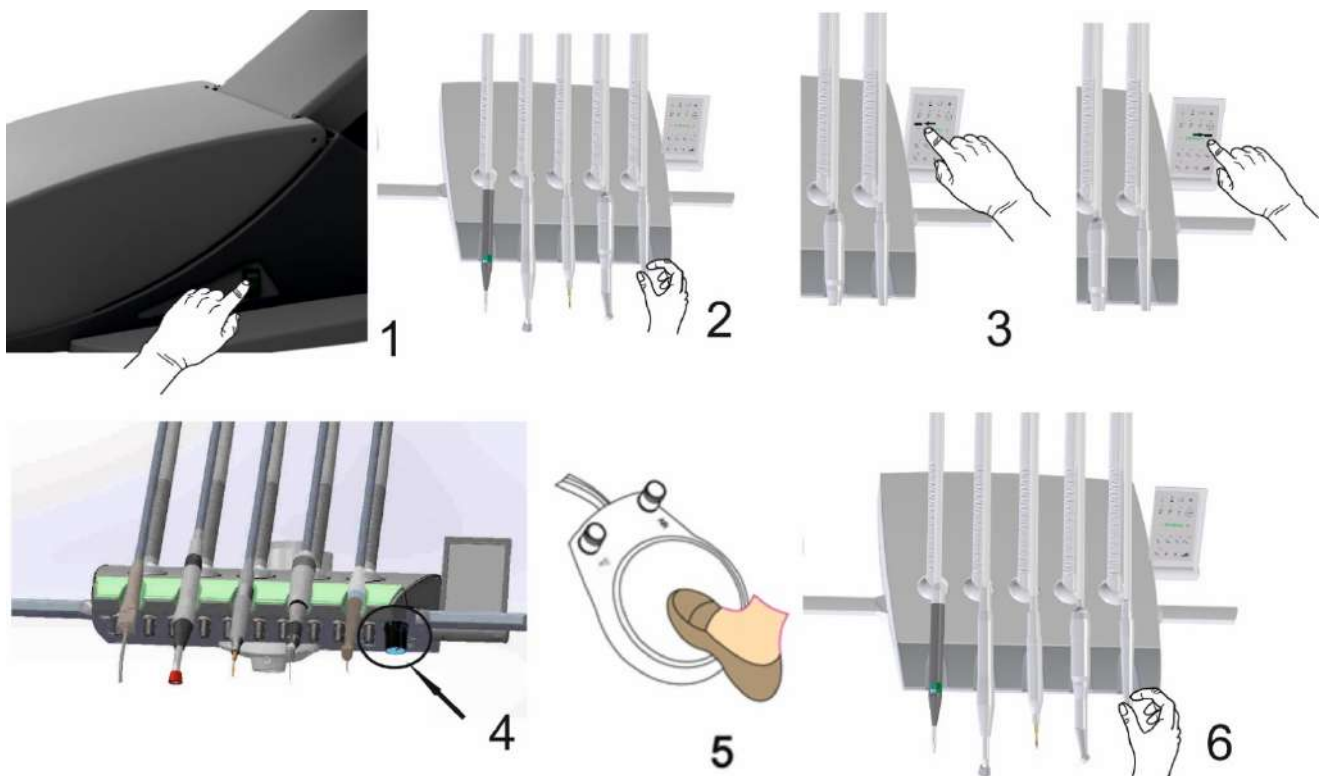

Figure 5.3.1.1 Setting the frequency of rotation of the micromotor in normal mode (pneumatic pedal).

4.6 – for multifunctional foot control

Set the foot control slider to the extreme right position corresponding to the maximum rotation frequency of the micromotor and smoothly change the rotation frequency from zero to the maximum value for this gradation.

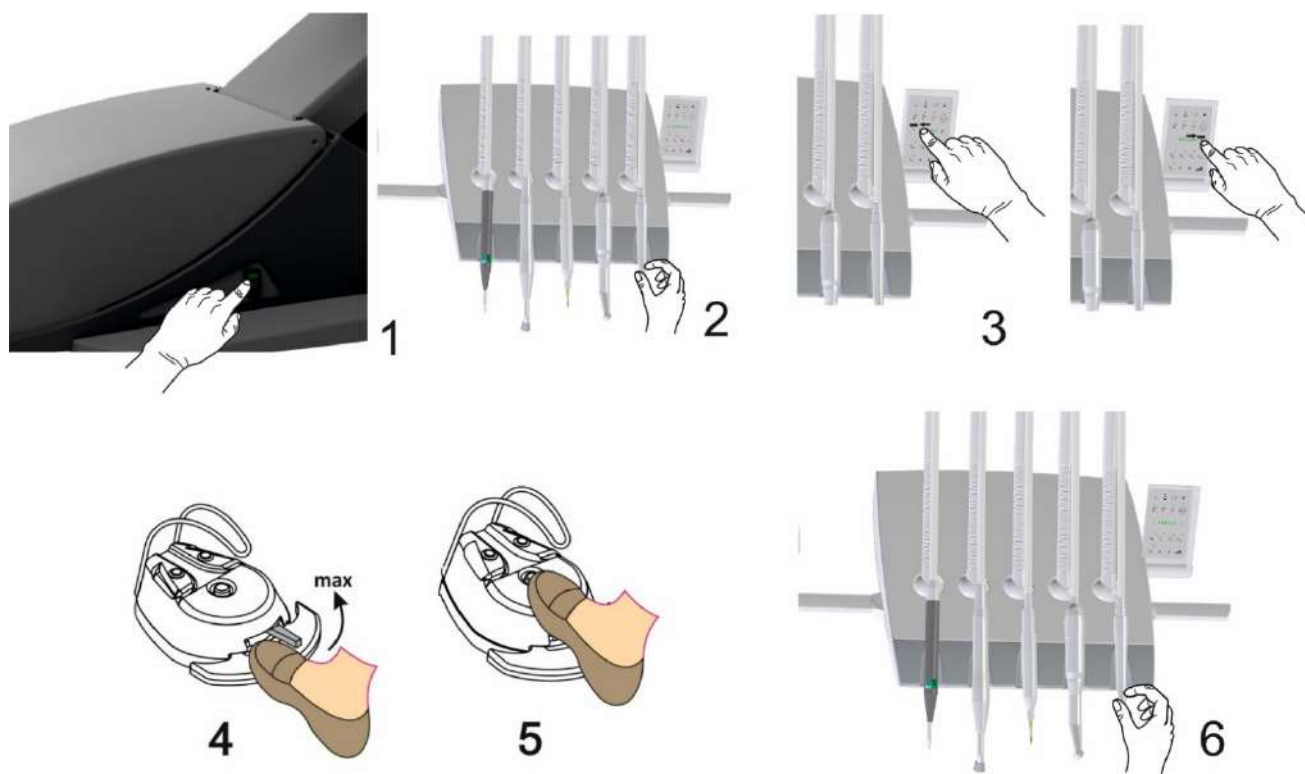

Figure 5.3.1.2 Adjusting the frequency of rotation of the micromotor in normal mode (multifunction pedal).

5. Press the foot control and check the set rotation speed of the micromotor.
6. To memorize the set rotation frequency and the corresponding indication, put the instrument down.

5.3.2 Adjusting the rotation frequency of the micromotor in ENDO mode

1. Take off the micromotor from the third workplace of the doctor table (see Figure 5.3.2.1).
2. Press the button to switch on ENDO mode, while the indicator flashes, which means that this mode is set.
3. By means of buttons \oplus and \ominus on the doctor table control panel set frequency of rotation of the micromotor. Button \oplus increases the rotation frequency, and button \ominus decreases the rotation frequency. Each indicator of doctor table displays a certain gradation and corresponds to the specified frequency of rotation of the micromotor.

For example, I-gradation – one indicator is on - revolutions of the micromotor \sim 870 rpm.
VIII-gradation – eight indicators are on - revolutions of the micromotor \sim 2900 rpm.

4.a – for pneumatic foot control

4. Set a knob of one or the both potentiometers  of doctor table to the extreme right position corresponding to maximum rotation frequency of the micromotor and smoothly change the rotation frequency from zero to the maximum value for this value gradation.

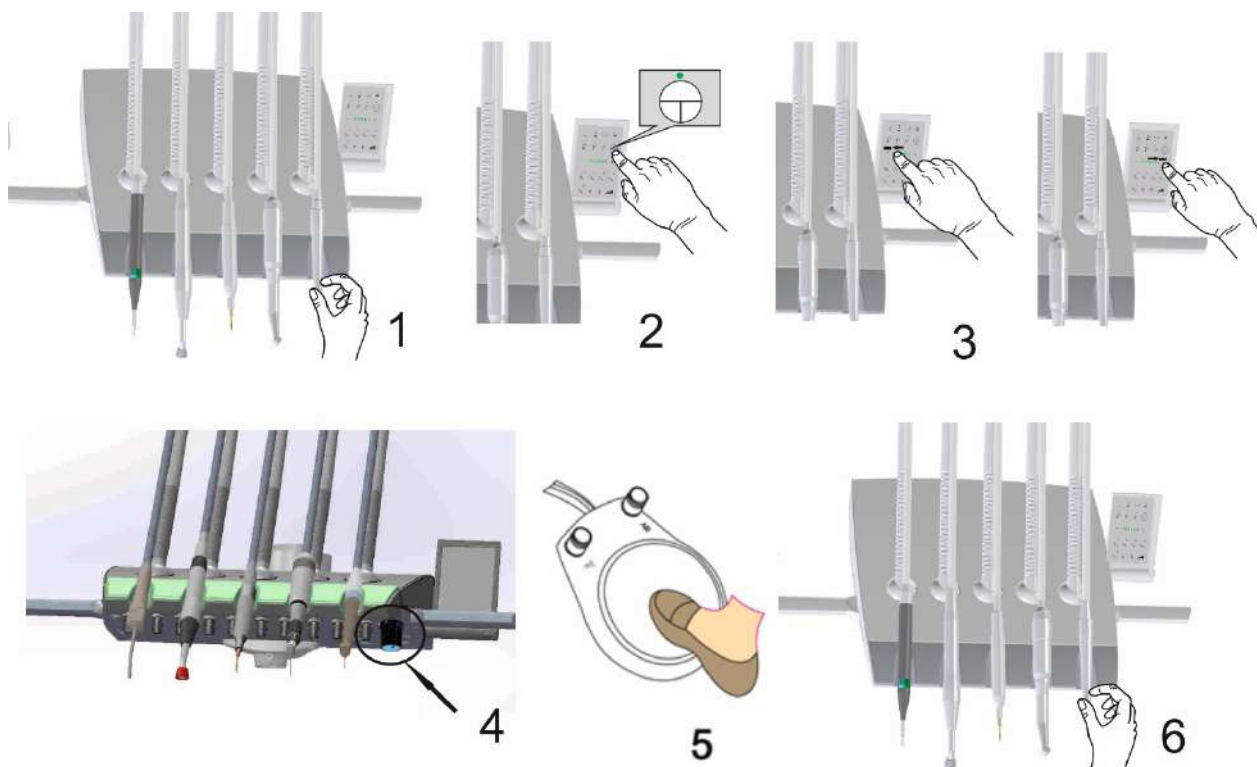

Figure 5.3.2.1 Adjusting the frequency of rotation of the micromotor in the ENDO mode (pneumatic pedal).

4.6 – for multifunction foot control

Set the foot control slider to the extreme right position corresponding to the maximum rotation frequency of the micromotor and smoothly change the rotation frequency from zero to the maximum value for this gradation.





Рисунок 5.3.2.2 Setting the frequency of rotation of the micromotor in the ENDO mode (multifunction pedal).

5. Press the foot control and check the set rotation speed of the micromotor.

6. To memorize the set rotation frequency and the corresponding indication, put the instrument down.

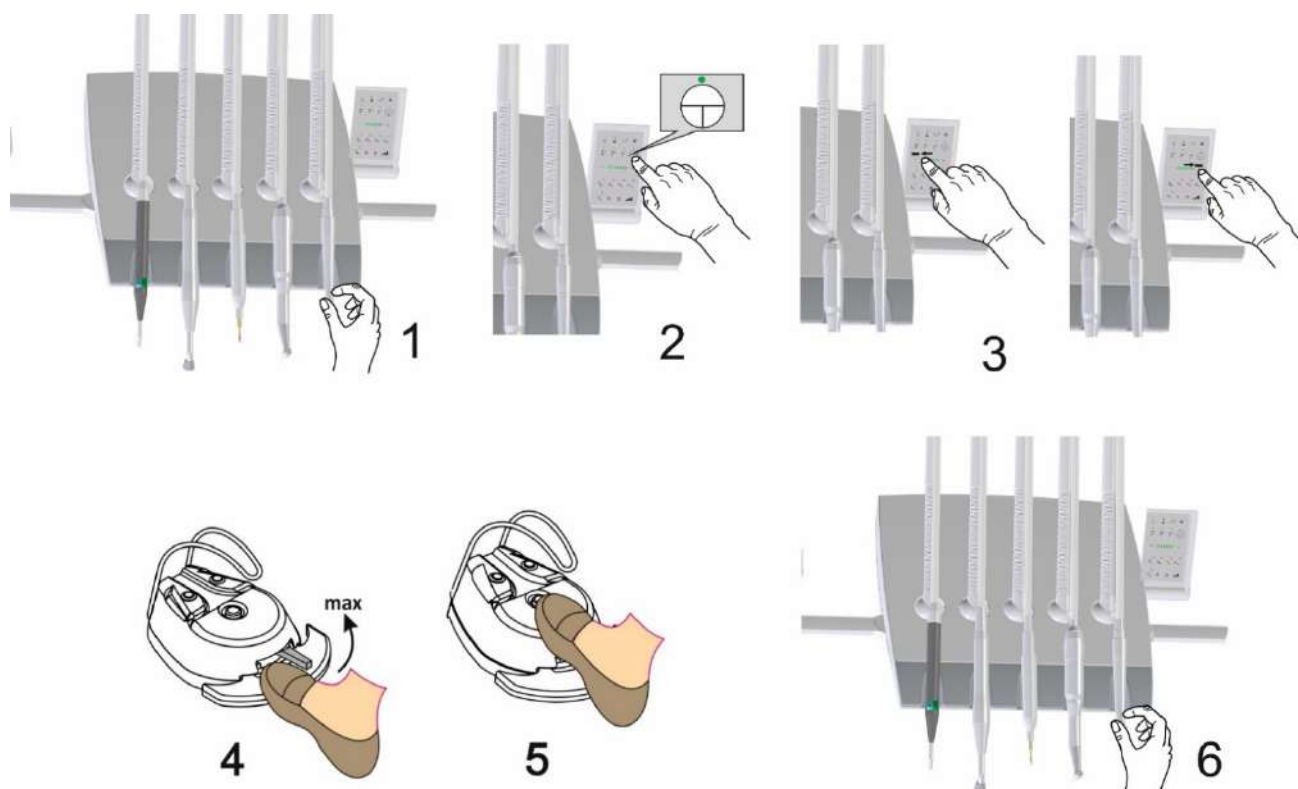
7. ENDO mode is turned off by pressing the button  again.

***Note.**

1. The second micromotor does not work in ENDO mode.
2. Micromotors MX, MX2 in the OPTIMA MX INT or OPTIMA MX2 INT set are adjustable from the OPTIMA control panel.
3. Micromotors MX2, MCX without the OPTIMA control panel in ENDO mode also do not work.

5.3.3 Adjusting the torque of the micromotor at the III workplace in ENDO mode

1. Press the button to switch on ENDO mode, while the indicator flashes, which means that this mode has been set (see Figure 5.3.3.1).

2. Press the ENDO button again for about 5 seconds and wait for the 8 vertically placed LEDs to blink.

***Note.** If the minimum torque is set, none of the 8 LEDs will blink.

3. By means of buttons \oplus and \ominus on the control panel select a torque value, at which the endofile, encountering a stronger obstacle under real conditions and reaching the selected force, will cause the micromotor to switch from direct to reverse motion.

Removing the obstacle automatically returns the micromotor to direct motion.

Button \oplus increases the torque, and button \ominus decreases the torque.

For normal mode, the maximum torque is 2.3 N·cm.

For the ENDO mode, each indicator of the doctor table displays a certain gradation and corresponds to a fixed torque value.

For example, I-gradation - one indicator lights up - torque \sim 0.3 N·cm.

VIII-gradation - eight indicators light up - torque \sim 2.3 N·cm.

***Note.** Any other operations at the dental unit are not possible at this time. The micromotor also does not rotate.

4. Press the ENDO button again to memorize the torque value. At the same time, the normal mode of operation of the dental facility is established. The ENDO indicator does not flash.

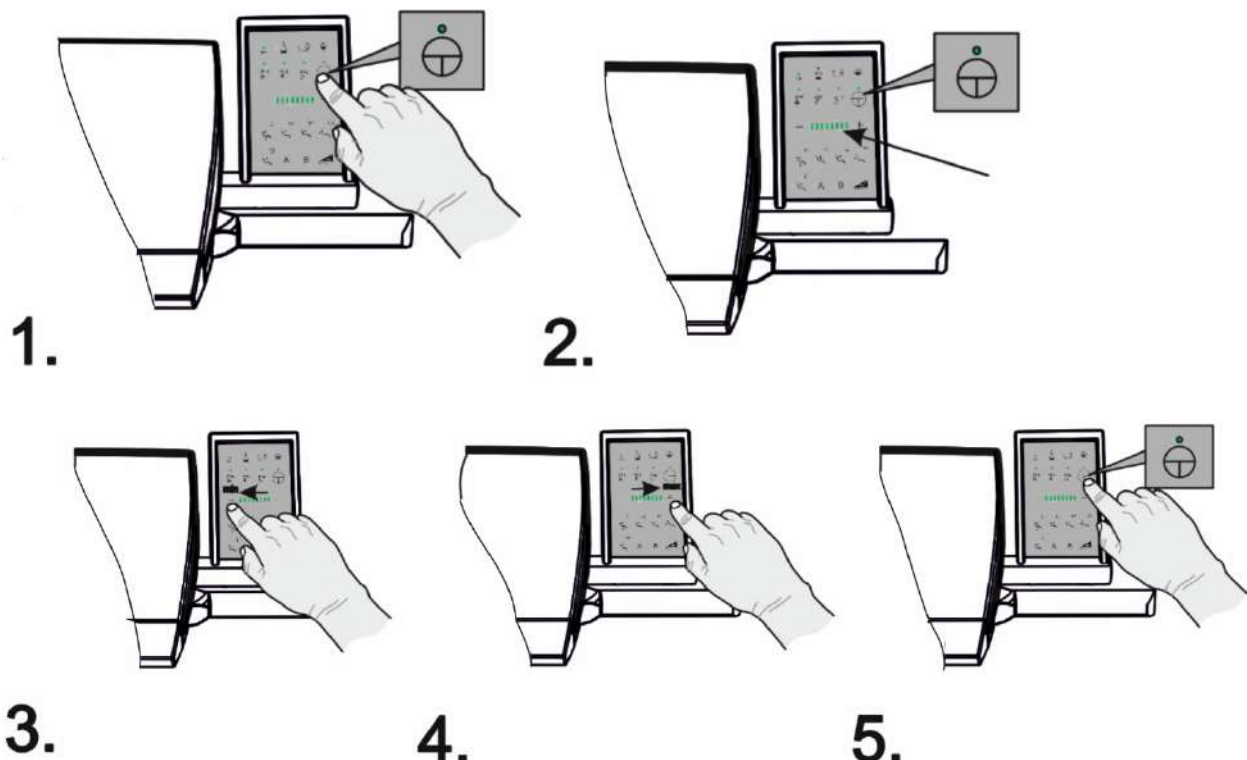

Figure 5.3.3.1 Adjusting the torque of the micromotor in ENDO mode

6 Assistant Table

On the assistant table there are: water and air saliva ejectors, syringe, curing lamp.

To turn on the saliva ejector, you need to take off the instrument from the holder. Disposable saliva ejector tips are not included in the set.

The dust and saliva suction unit works only with the high-speed suction aggregate.

For productive operation of the water saliva ejector, the pressure in the water supply network is not less than 3 bar.



Figure 6.1.

6.1 Assistant table control panel

<p>Left part</p>	<p>Right part</p>	<p>P Button for programming positions P1, P2, P3.</p> <hr/> <p> When pressed for a long time - raising the backrest of the chair to the position for rinsing the oral cavity. With repeated long pressing, the backrest returns to its previous position.</p> <hr/> <p> Button for filling a cup with water</p> <hr/> <p> Cuspidor bowl rinsing button</p> <hr/> <p>P1 With a short press, the chair is automatically moved to the programmed position P1. When pressed for a long time, the chair moves up.</p> <hr/> <p>P2 With a short press, the chair is automatically moved to the programmed position P2. With a long press, the backrest of the patient chair is raised.</p> <hr/> <p>P3 With a short press, the chair is automatically moved to the programmed position P3. With a long press, the backrest of the patient chair is lowered</p> <hr/> <p>0 With a short press - installation of the chair in "0" position. When pressed for a long time - moving the chair down.</p>
------------------	-------------------	--

Figure 6.1.1.

6.2 Adjusting the working modes of instruments on the assistant table

If there are working tools on the assistant table (diathermocoagulator, photopolymer lamp, scaler, etc.), the working modes for them are set similarly to clause 5.2. "Regulation of the working modes of instruments on the doctor table".

6.3 Programming working positions of the dental chair

1. Move chair to the zero position by briefly pressing button .
2. Select the desired position of the chair, which must be assigned, for example, to the P1 program.
3. After that, while holding down the P button, briefly press the P1 button. A sound signal will confirm that the working position is entered into the memory.
4. In the future, by briefly pressing the P1 button, the chair will automatically move to the programmed position.
5. The working positions for buttons P2, P3 are programmed in the same way.
6. Functions of the buttons on the remote control of the assistant table correspond to the functions on the joystick of the patient chair. The P button on the control panel of the assistant table corresponds to the M button on the side of the chair (see Figure 6.2.1)

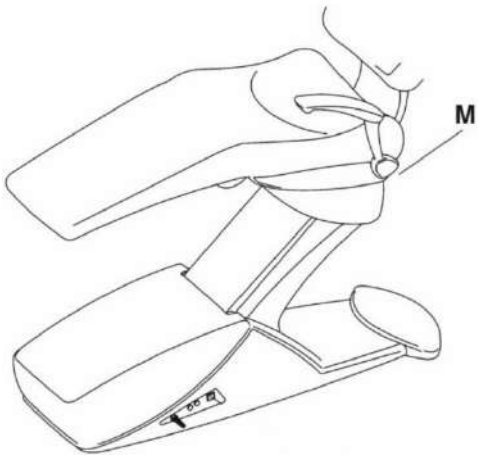

Figure 6.3.1a- ECO NEXT.

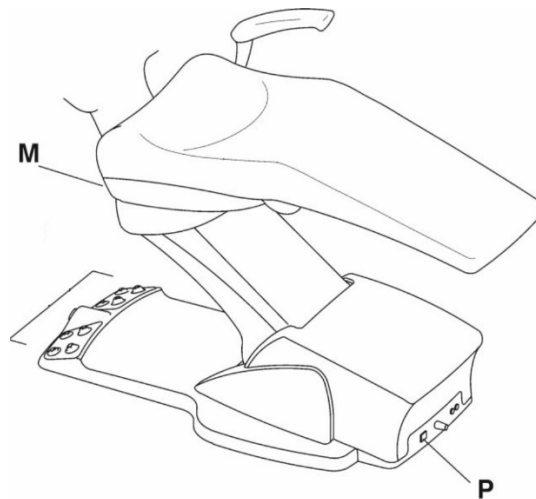

Figure 6.3.16- ECO 19.

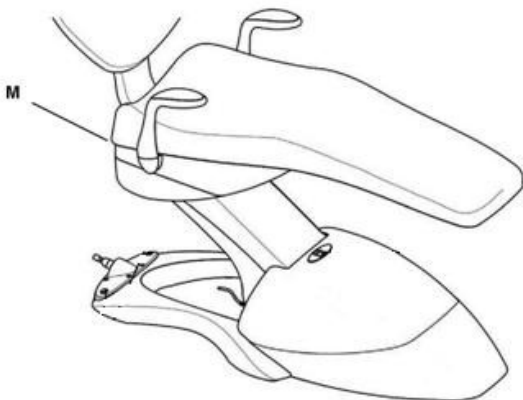

Figure 6.3.1b- STING

***Note.** Programs P1, P2, P3 work only with STING, ECO NEXT, ECO 19 chairs (with programs) and other chairs in which the T2000 control board is installed.

7 Water Unit

7.1 Functions of filling the cup and rinsing the cuspidor bowl

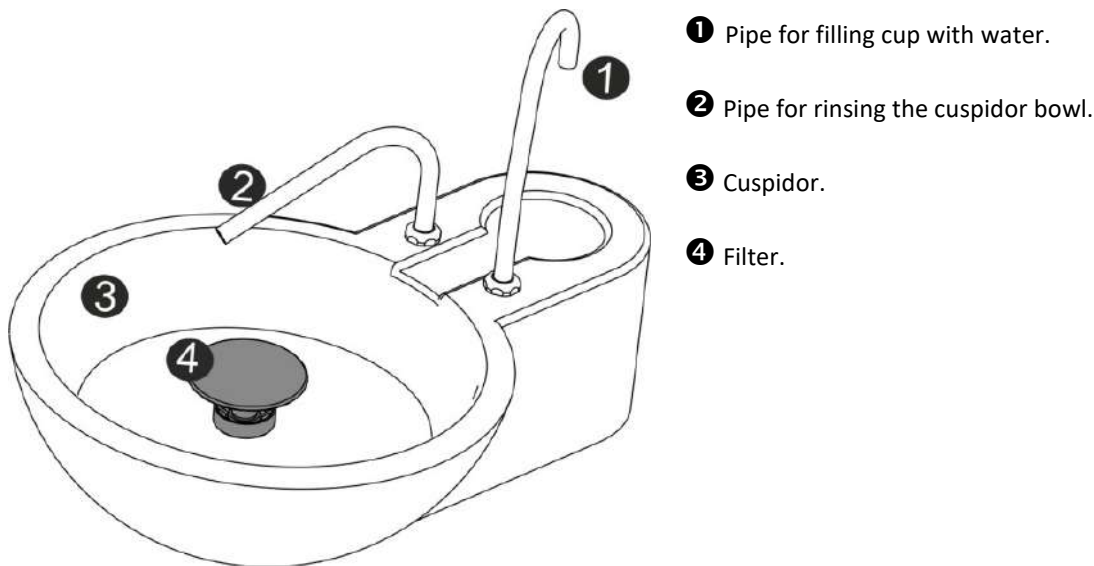



Figure 7.1.1.



ATTENTION! Cuspidor turning blocks the chair movement

Functions of filling the cup with water and rinsing the cuspidor bowl are activated by pressing the corresponding buttons on the control panel of doctor or assistant:

- when pressing the **cup filling button**  on the control panel of doctor table or on the assistant table control panel (for versions with the assistant table control panel) - water enters the cup within 3 seconds or as long as the control button is pressed. If you press the control panel button again before 3 seconds, water supply to the cup stops;
- **in case of need, the cup filling time can be increased (see Section 7.2 Programming the glass filling time);**
 - when pressing the **bowl rinsing button**  on the control panel of doctor table or on the assistant table control panel (for versions with the assistant table control panel) – the bowl is being rinsed for approximately 10÷12 seconds. or as long as the control button is pressed. If you press the remote control button again before (10-12) seconds, the bowl rinse stops.
- **In case of need, the cuspidor rinsing time can be increased (see Section 7.2 Programming the cuspidor rinsing time).**



Do not pour liquids into the cuspidor when the unit is switched off.

7.2 Programming time of filling cup and rinsing cuspidor

Cup filling programming time

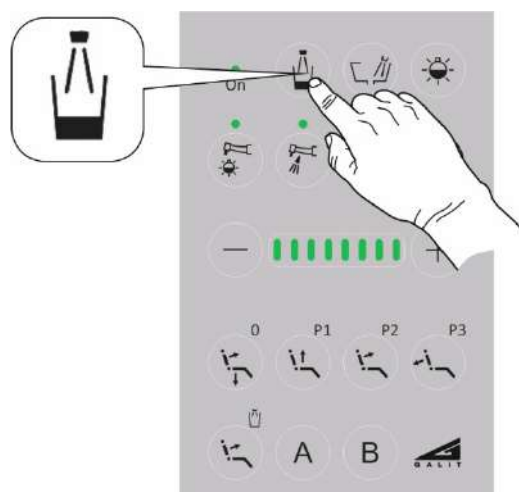

1. Time of filling the cup is remembered when the cup button is pressed for a long time (more than 3 sec).



>3 sec.

2. When pressing the button for a short time (less than 3 seconds), the cup activates the last memorized time value.
By default, time for filling the cup is **3 seconds**.



<3 sec.

3. If the button is briefly pressed again before the memorized time, filling stops.

4. All settings are saved in the energy independent memory of the microcontroller after the unit is turned off.

Програмування часу змиву плювальниці

5. Rinsing time of the cuspidor is memorized when the rinsing button is pressed for a long time (more than 3 seconds).



>3 sec.

6. When the button is pressed for a short time (less than 3 seconds), the last memorized time value is activated.
By default, the time for rinsing the cuspidor is **10 seconds**.



<3 sec.

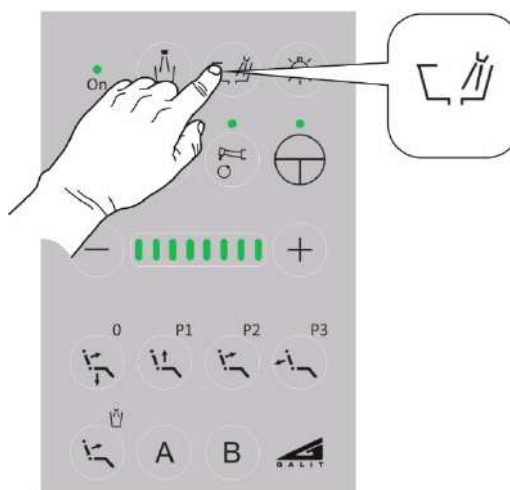

7. If the button is briefly pressed again before the memorized time, rinsing stops.

8. All settings are saved in the energy independent memory of the microcontroller after the unit is turned off.

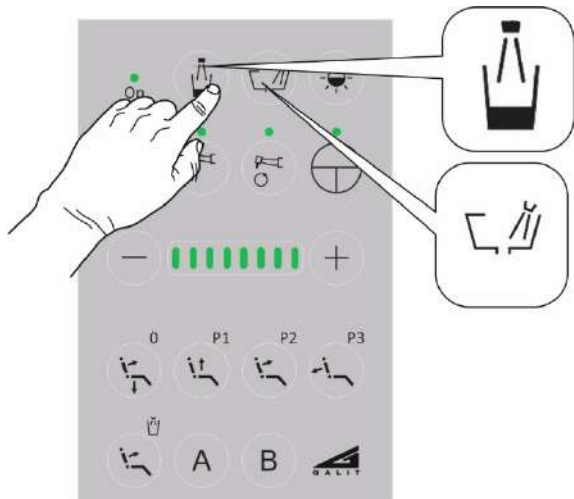

9. If necessary, you can restore the initial (“factory”) values of the cup filling time of **3 seconds** and the cuspidor rinsing time of **10 seconds**.

To do this, you need to perform the following sequence of actions:

- press the bowl rinsing and cup filling buttons **at the same time**;
- switch on the dental unit.



10. The **maximum** programmable value of rinsing or filling time is **33 seconds**.

7.3 Memorization of "spray" and "illumination" modes for I-IV instruments

For I-IV instruments, the "spray" and "illumination" modes are memorized for each instrument separately. All settings are stored in the energy independent memory of the microcontroller.

Adjustment of "spray" and "illumination" modes for I-IV instruments:

1. Take off the instrument from the holder.
2. Switch on (or switch off) "illumination" of the instrument. Indicator is on – "illumination" is on.
3. Switch on (or switch off) "spray" for instruments cooling. Indicator is on – "spray" is on.
4. Insert the instrument in the holder.
5. **When the instrument is taken off from the holder again, the "spray" and "illumination" mode will be the same as when the instrument was last used.**

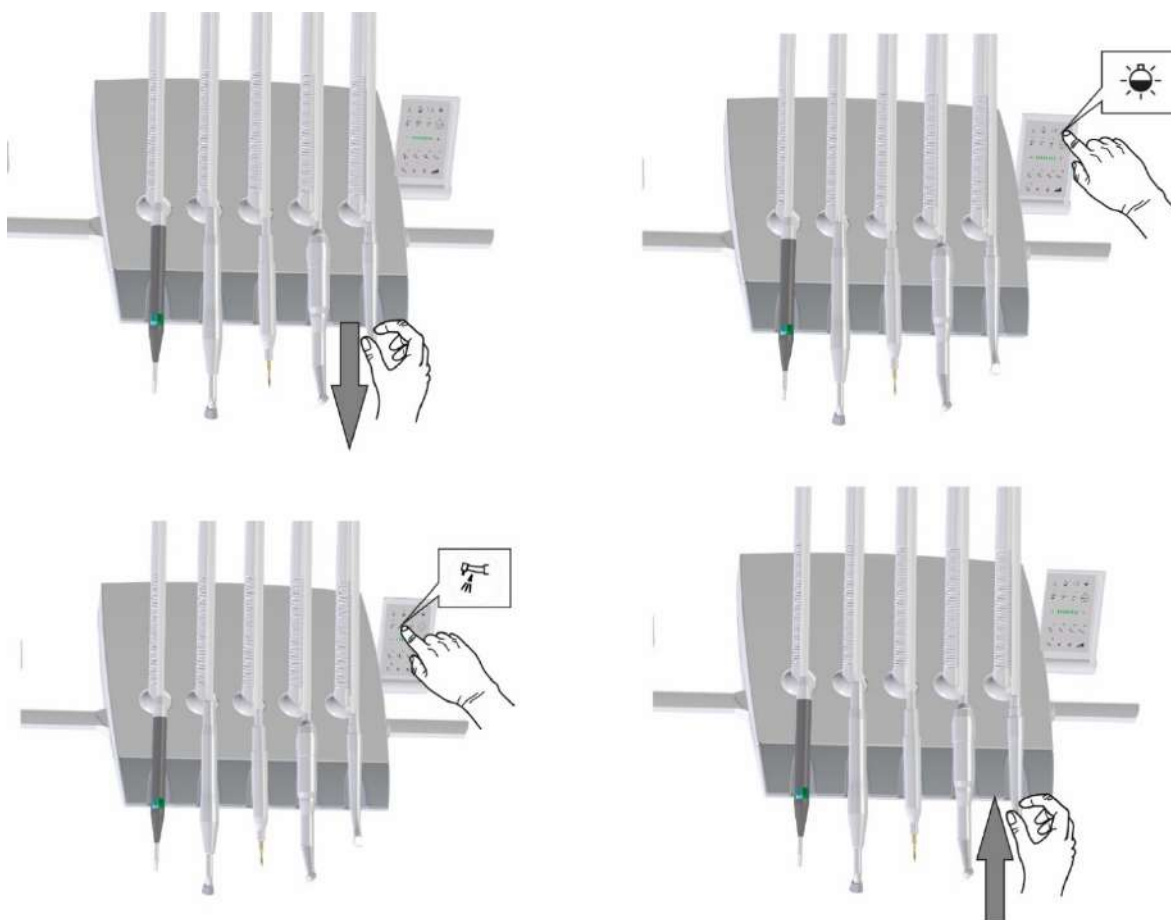

Figure 7.3.1

When the instrument is operating in "SPRAY" mode, after releasing the foot control, the water-air mixture stops being supplied to the instrument. Then, with a pause of 0.5 seconds, water is blown out from the "spray" channel for 1 second.



ATTENTION! Function of blowing out water after releasing the foot control can be disabled or re-enabled. It is recommended to configure this function with the involvement of a qualified technician or a representative of the PC Galit service department».

Note.

1. The "illumination" memory function is **turned on** by DIP switch 4 to ON position.
2. The "illumination" memory function is **turned off** by DIP switch 4 to OFF position in case of using micromotors MCX and MX2 of "Bien Air" company.
3. Regardless of DIP switch 4 position, the function is disabled for scaler at IV.

7.4 Adjusting the water-air mixture (SPRAY)

Adjustment is carried out on the control panel with the help of buttons "A" and "B" with a short press-release of the button, provided that at least one instrument is selected. Each time you press the "B" button, the water flow changes, increases stepwise by one gradation, from the initial value to the maximum value of 90 ml/min. When the maximum amount of water in the spray is reached and the button is pressed again, the amount of water remains constant. Each time you press "A" button, the water flow changes, decreases by one gradation, from the initial value to a minimum of 10 ml/min. When the minimum amount of water in the spray is reached and the button is pressed again, the amount of water remains constant. There are five working positions of water: 10 ml/min, 20 ml/min, 30 ml/min, 50 ml/min, 90 ml/min

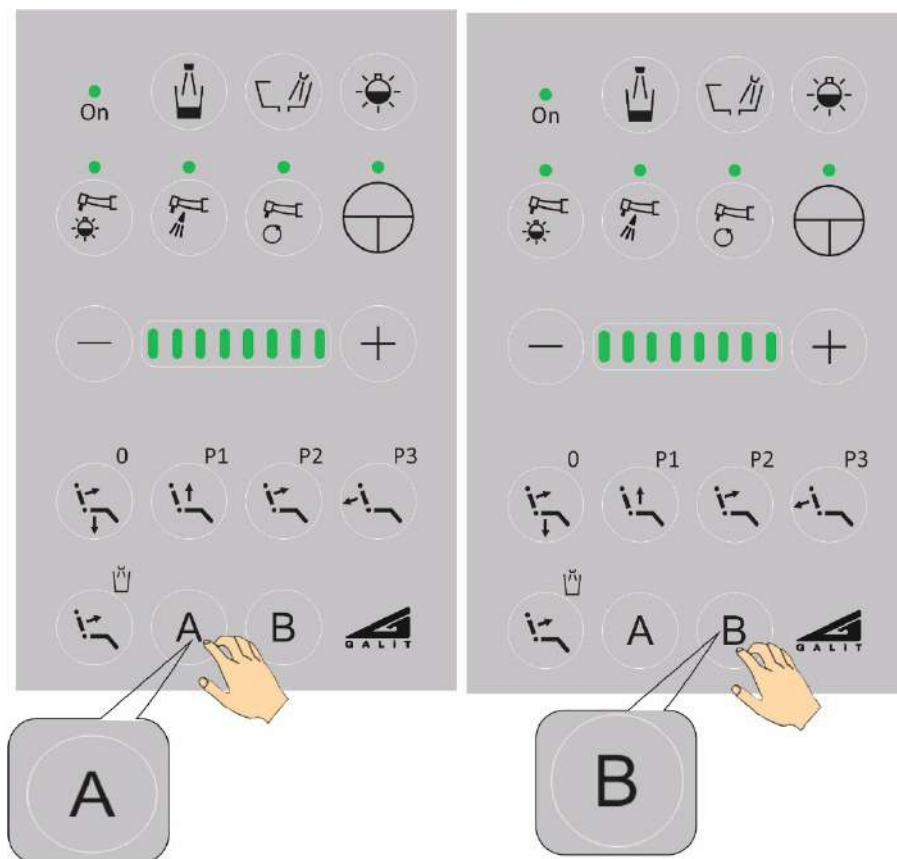

Level of water in the spray is set and memorized for each dental instrument separately.

When all instruments are inserted, the servo valve stops working and spray adjustment is impossible. It should also be noted that in this version of the doctor table there are no manual water flow regulators for each instrument separately.

7.5 Distilled Water System (DWS)

Filling the distilled water system with a bayonet connection:

- turn off the air supply switch **pos. 1** into the distilled water system (Fig.7.5.1);
- unscrew the water container **pos. 2**. **To do this, turn the water container to stop and pull it down вниз (Рис.7.5.2);**
- pour distilled water into the container;
- install the container with water in the holder. **To do this, install the filled water container on the upper part of the bayonet connection and rotate until it is fully fixed;**
- turn on the air supply switch to the distilled water system (top position of the switch).

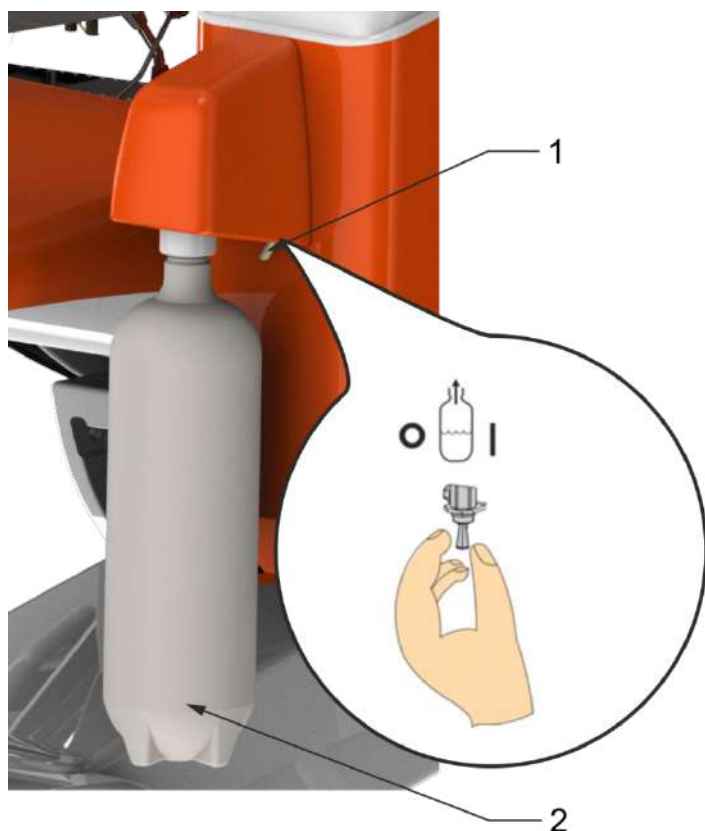

1 – the switch to supply air into the distilled water system,
2 – container for water with bayonet connection.

Figure 7.5.1

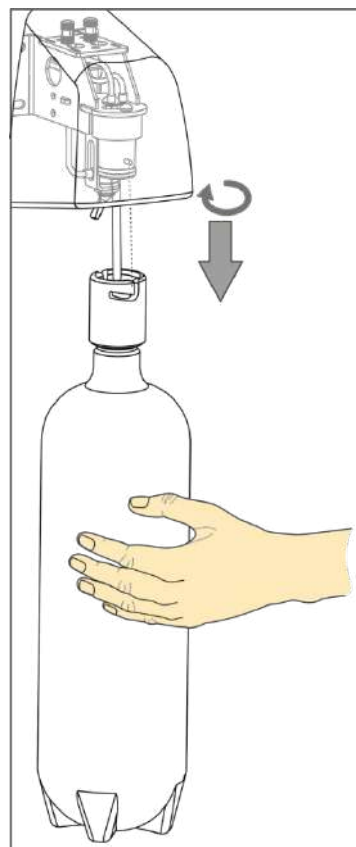

Figure 7.5.2

ATTENTION! In order to prevent contamination of channels of hydraulic system of the unit and the hydraulic system of the instruments, fill the container only with distilled water. Presence of continuous hissing around the neck of the container with water indicates a leak. To eliminate leakage, tighten the container or replace the gasket.



Use the water bottle carefully. Always check the bottle for damage before filling it and every time it is dropped. If cracks or other signs of damage are found, stop using the bottle immediately and replace it with a new one

To disinfect the distilled water system, use FD 322 from Durr Dental GmbH & Co. KG", or use disposable bottles.



7.6 Adjusting the tension of the instrument delivery levers

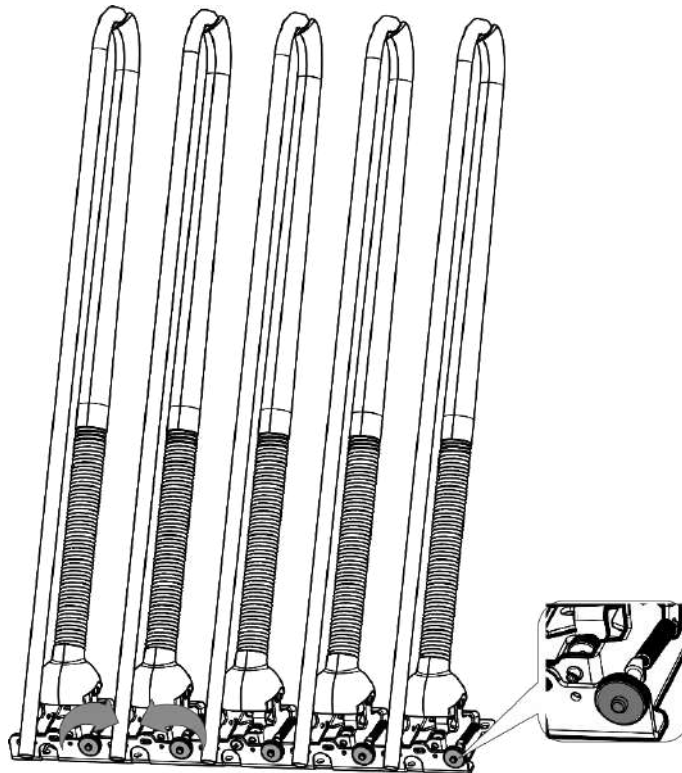

To access the tension regulators of the instrument delivery levers, the upper cover of the doctor table must be removed.

To change the tension force of the instrument delivery levers, you need to scroll through the controls:

- to the left - loosen the tension;
- to the right - increase tension

8 Maintenance

8.1 Recommended products for care, cleaning and disinfection

ATTENTION! It is **STRICTLY** forbidden to use solutions containing **CHLORINE** for disinfection of dental equipment!

It is **RECOMMENDED** to use disinfectants of Durr Dental, Orochemie and METASYS companies.

ATTENTION! Perform maintenance work only after turning off the equipment.



ATTENTION! It is forbidden to pour or spray solutions directly on the surface of the unit to prevent them from getting inside.

Before processing sensitive surfaces, check compatibility of materials with disinfectants in an inconspicuous place.

ATTENTION! Before use, be sure to read the labelling and information about the product that will be used for cleaning and disinfection.

The materials of which the unit is made provide convenient and easy cleaning and disinfection.

Use only a soft cloth moistened with a cleaning or disinfecting solution.

Use disinfectants only as intended, in accordance with the recommendations provided by manufacturers of disinfectants and dental equipment.







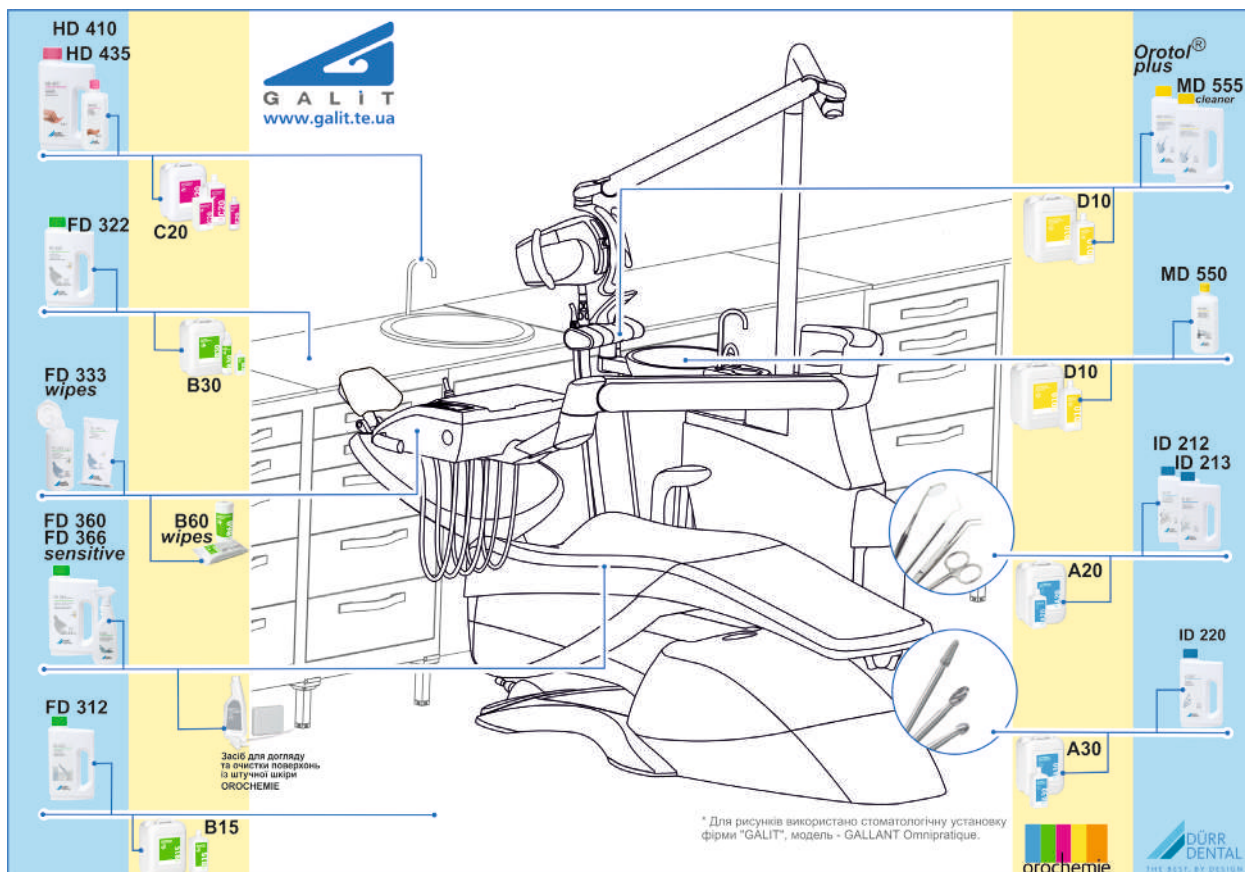





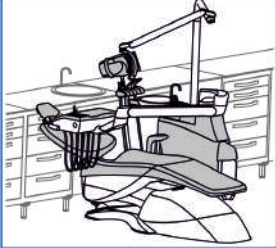

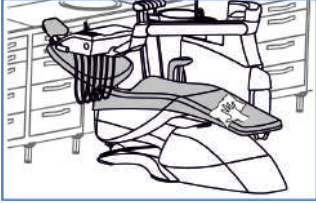



National hygiene and disinfection requirements and recommendations must be followed, e.g. B. Robert Koch Institute (RKI), American Dental Association (ADA), Centers for Disease Control and Prevention (CDC), etc.

Scheme of disinfection with the use of means "Durr Dental GmbH & Co. KG" and "Orochemie GmbH + Co. KG" (only for Ukraine);



Products recommended for cleaning and disinfection care (only for Ukraine)

	Durr Dental GmbH & Co. KG	Orochemie GmbH + Co. KG	
	Quick disinfection of surfaces	 FD322	 B30
	Disinfection of delicate surfaces, for example, plastic, vinyl upholstery, displays, acrylic glass	 FD366	
	Cleaning and care of vinyl upholstery	 FD360	 Facility for cleaning and care of artificial leather products Orochemie * * Do not use special sponges to clean the skin.
	Disinfection of dental handpieces	 FD333 wipes	 B60
	Disinfection of intraoral camera	 FD350 wipes	 B60
	For disinfection and cleaning of instruments	 ID212	 A20
		 ID213	



For disinfection and cleaning
of rotating instruments
(including burs, cutters and
drills)



ID220



A30

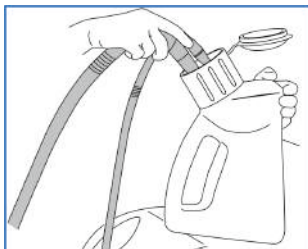

For disinfection and cleaning
of suction systems and
cuspidors



Orotol® plus



MD555



D10



For disinfection and cleaning
of cuspidors



MD550



D10



For disinfection of surfaces
(floors, walls, etc.)



FD 312



B15



Hand disinfection and
cleaning



HD 410



HD435



C20

**METASYS Medizintechnik
GmbH**

Hydrogen peroxide 3%

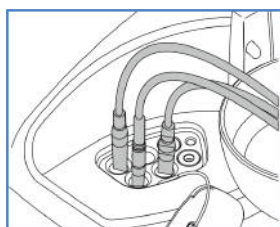

For internal hose channels
and unit water ways



GREEN&CLEAN WK

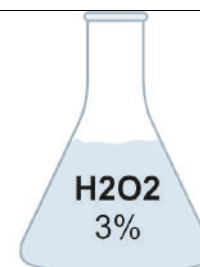

Detailed information on these disinfectants can be obtained from the website of the product manufacturers:

- 1) www.duerrdental.com - site of company Durr Dental GmbH & Co.;
- 2) www.orochemie.de/ - site of company "Orochemie GmbH + Co. KG";
- 3) www.metasys.com - site of company Metasys.

8.2 Care of instruments

Constant care is necessary for the perfect functioning of each instrument. This is simple care and is provided by special means. Lubrication and maintenance of instruments should be carried out together with cleaning, disinfection and sterilization.



For each specific instrument, it is necessary to use means and recommendations that are indicated in the passport (instructions) for this instrument. Use of other means, not specified in the passport (instructions) or not agreed with the Galit company, voids the warranty for this instrument.

Bien-Air instruments care products:

Cleaning



Spraynet (order code REF 1600036-006) aerosol with cleaning agent for instruments and devices. It is recommended to use before sterilization. Dissolves and rinses even heavy pollution.

For cleaning and maintenance of hoses, cables and surfaces of devices, as well as electric micromotors, it is recommended to use a napkin well moistened with Spraynet cleaning agent. Spraynet aerosol is suitable for cleaning all turbines, straight and angular handpieces, as well as air motors and electric micromotors without angular brushes.

All instruments cleaned from the inside with Spraynet must be lubricated before sterilization and storage.

Grease

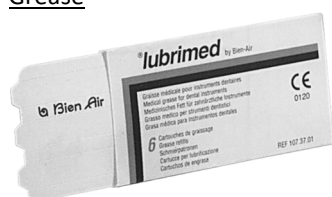

Lubrimed (order code REF 1600037-006) medical consistency grease for bearing turbines. Greasing of the turbine head is carried out with Lubrimed greasing instrument (order code REF 1000003-001). Instruments must be greased before each sterilization or at least twice a day.

Lubrication



Lubrifluid (order code REF 1600064-006) is an aerosol for lubricating contra angles, air motors and electric micromotors.

Sterilization

- in an autoclave up to 136 °C / 2.2 bar for 10-30 minutes;
- by ethylene oxide at 60°C;
- drying cycle: maximum 136 °C for a maximum of 30 minutes.

Detailed recommendations and rules for the care of instruments are presented in the passport (instructions) for this instrument.

Detailed recommendations for use of instruments care products are presented in the instructions for using these instruments.

8.3 Lamp (dental)

8.3.1 Lamp (dental) MAIA

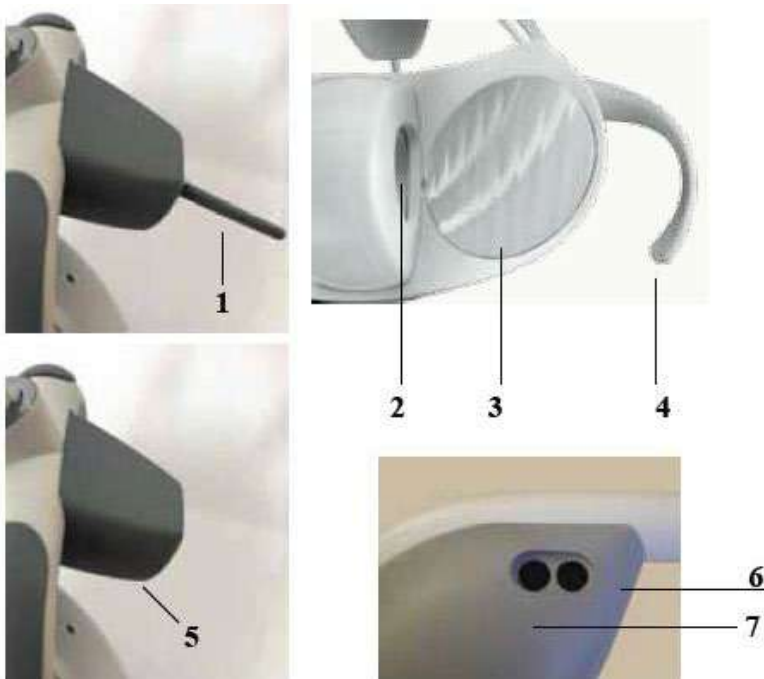

- 1- Switch
- 2- Lens
- 3- Parabolic mirror
- 4- Handle
- 5- Contactless switch
- 6- Fuses
- 7- Transformer

Each time the lamp is turned on, the light intensity will be at the level that was set before the lamp was turned off.

Lighting intensity is regulated using a switch or a contactless switch (depending on the design of the lamp) .

The **contactless switch** allows you to turn on or off the lamp without direct contact, thus eliminating possibility of cross-contamination (depending on the design of the lamp).

1. Lamp "MAIA" , version with joystick

- To turn the lamp on and off, press and release the regulator lever on the left or right side.
- Light intensity adjustment:

The lamp is switched on at maximum intensity.

To decrease the light intensity, press and hold the control lever on the left side (rear view of the lamp) until the desired light intensity is reached. This control switch does not allow you to increase the intensity of the light.

2. Lamp "MAIA" , version with contactless sensor

- To turn on or off the lamp, approach the sensor at a maximum distance of 3 cm.
- To adjust the light intensity, stay close to the sensor.

3. Sterilization of lamp handles

Press "A" button and remove the handle. When installing the handles back, press them as far as they will go.

Handles are delivered in a non-sterile state, the handles must be sterilized before use.



Detailed information on the operation and maintenance of the lamp is given in the "Instructions for the dental lamp", which is included in the delivery set of the unit.

8.3.2 Lamp (dental) EVA



- 1- the handles are removable and autoclavable.
- 2- a bright diode on the lamp immediately shows the level of illumination and colour temperature.
- 3- 3D rotation of the lamp > 360° to illuminate every part of the mouth.
- 4- safe and comfortable to hold.

Lighting intensity is regulated using a switch or a contactless switch (depending on the design of the lamp).

The contactless switch allows you to turn on or off the lamp without direct contact, thus eliminating the possibility of cross-contamination (depending on the design of the lamp).

1. Lamp "EVA", version with joystick

- To turn the lamp on and off, press and release the regulator lever on the left or right side.
- Light intensity adjustment:

The lamp is switched on at maximum intensity.

To decrease the light intensity, press and hold the control lever on the left side (rear view of the lamp) until the desired light intensity is reached. This control switch does not allow you to increase the intensity of the light.

2. Lamp "EVA", version with contactless sensor

- To turn on or off the lamp, approach the sensor at a maximum distance of 3 cm.
- To adjust the light intensity, stay close to the sensor.

3. Sterilization of lamp handles

Press the button and remove the handle. When installing the handles back, press them as far as they will go.

Handles are delivered in a non-sterile state, the handles must be sterilized before use.



Detailed information on the operation and maintenance of the lamp is given in the "Instructions for the dental lamp", which is included in the delivery set of the unit.

8.3.3. Lamp (dental) ALYA

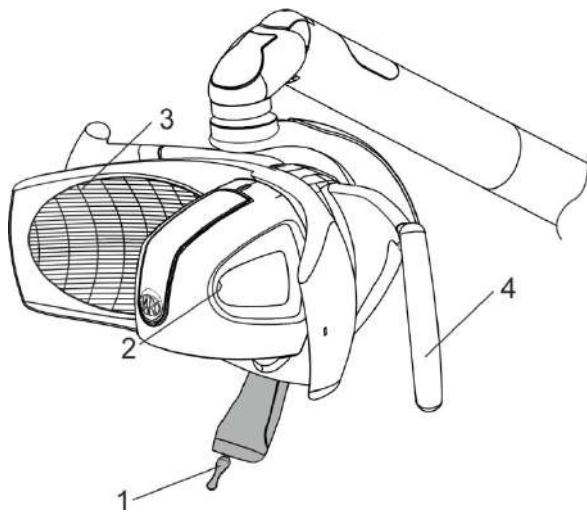

- 1 – Switch
- 2 - LED
- 3 - Parabola
- 4 – Handle

Sterilization of lamp handles Press «A» button and remove the handle. When installing the handles back, press them as far as they will go.

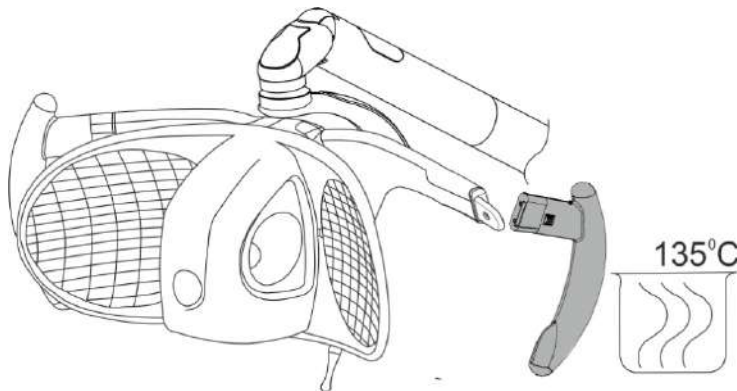

Handles can be sterilized at a standard cycle of 121° / 134° maximum 200 times.

Cleaning of parabolas (pos. 3).

Clean with cotton wool and ethyl alcohol. Do not use detergents that contain surfactants or water repellents that can leave stains.

ON/OFF:

- To turn on and off, press and release the button. Hold this button to adjust the intensity.

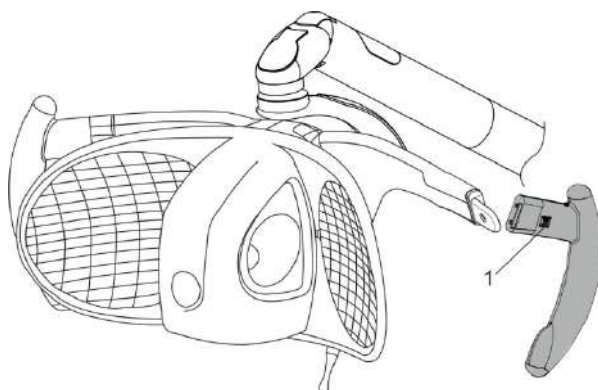

Handles removal

- Put your hands on the buttons.
- Press the buttons simultaneously and disconnect the handles.
- Install the handles on both sides at the same time and press them.



Detailed information on the operation and maintenance of the lamp is given in the "Instructions for the dental lamp", which is included in the delivery set of the unit.

8.4 Cuspidor Filter Cleaning

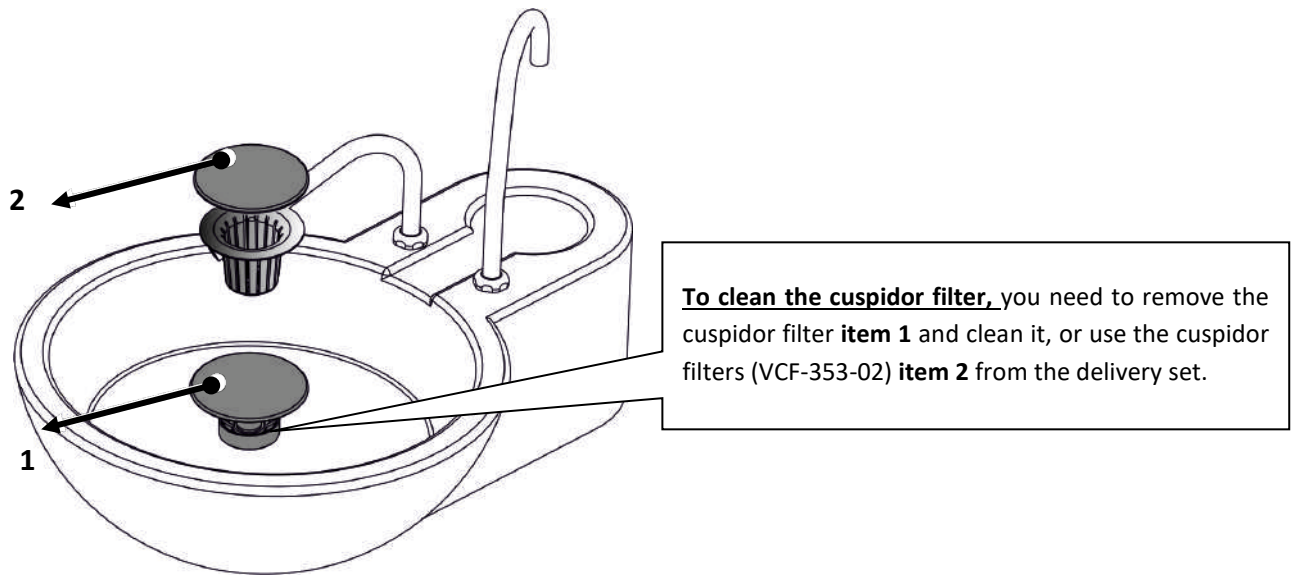

Figure 8.4.1

8.5 Cleaning the exhaust air filter of pneumatic outlets

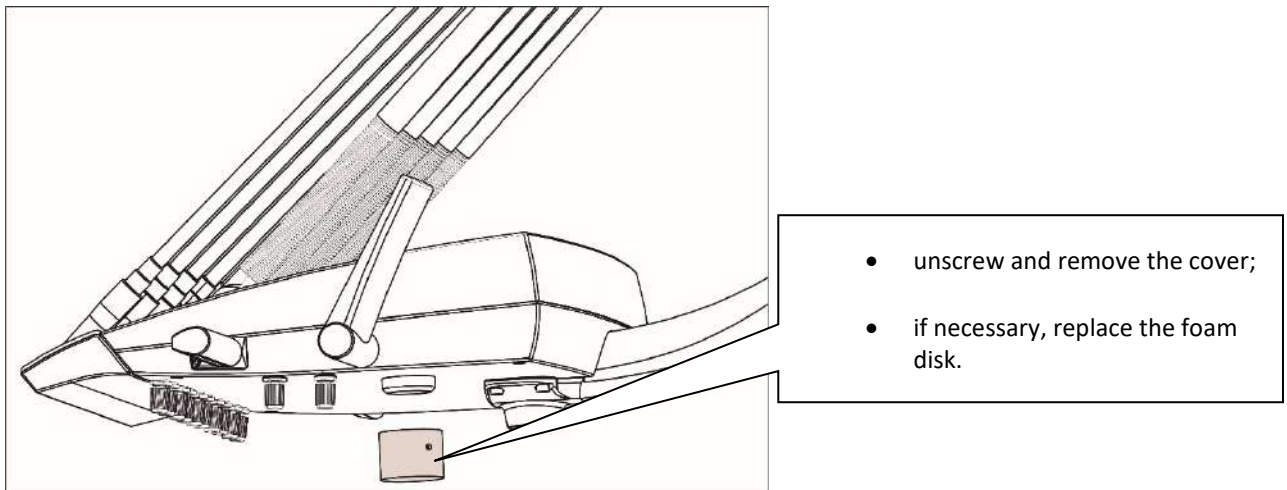

Figure 8.5.1.

8.6 Filling the container for filling the cup and rinsing the cuspidor

Filling the container for filling the cup and rinsing the cuspidor:

- turn off the switch (item 1. Figure 8.6.1.) of the air supply to the water tank;
- unscrew the valve, but do not remove the cover of the container itself;
- using a funnel, pour water into the container (maximum 4 liters) to fill the cup and rinse the cuspidor.

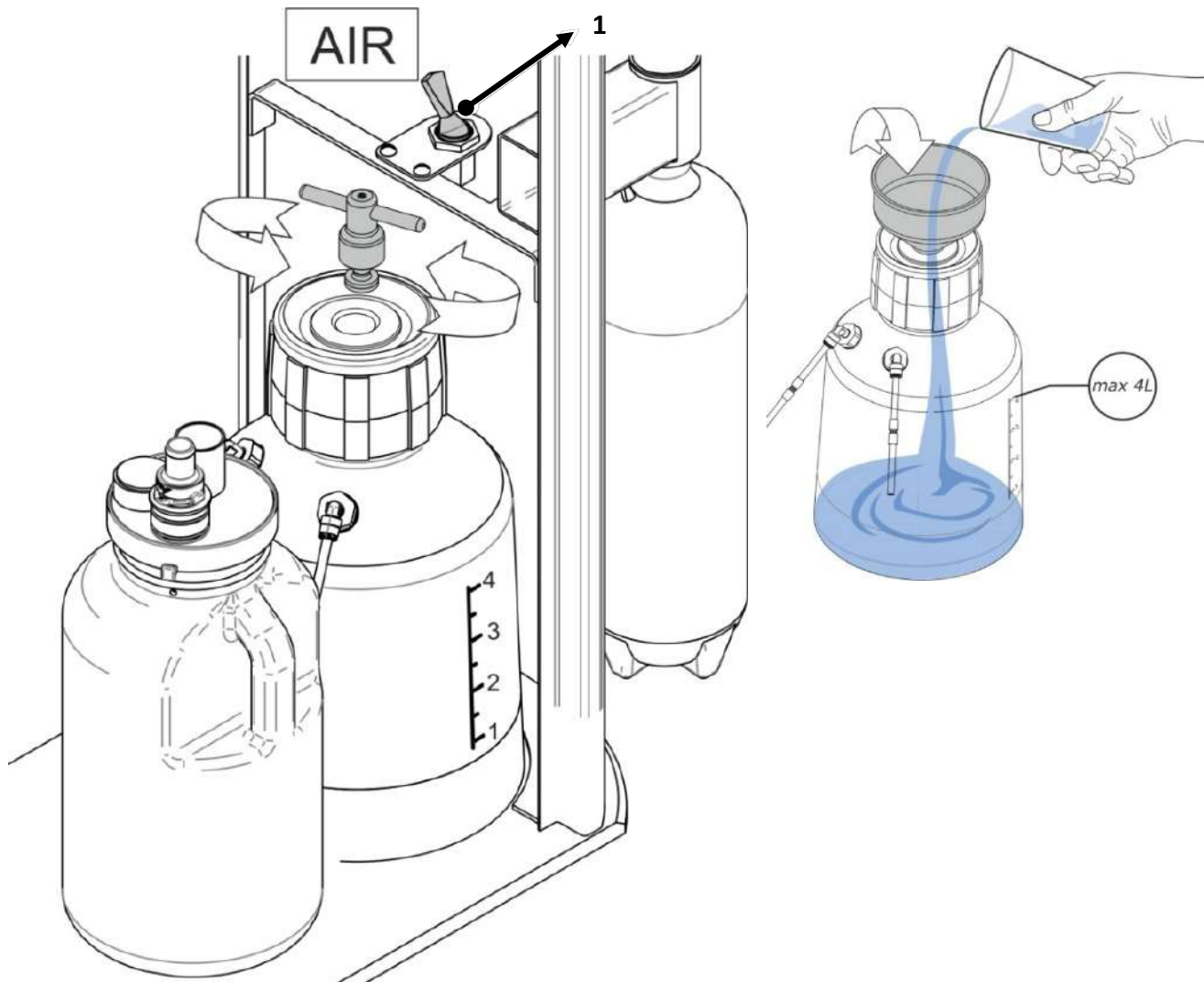

Figure 8.6.1

8.7 Replacement of the bacterial filter

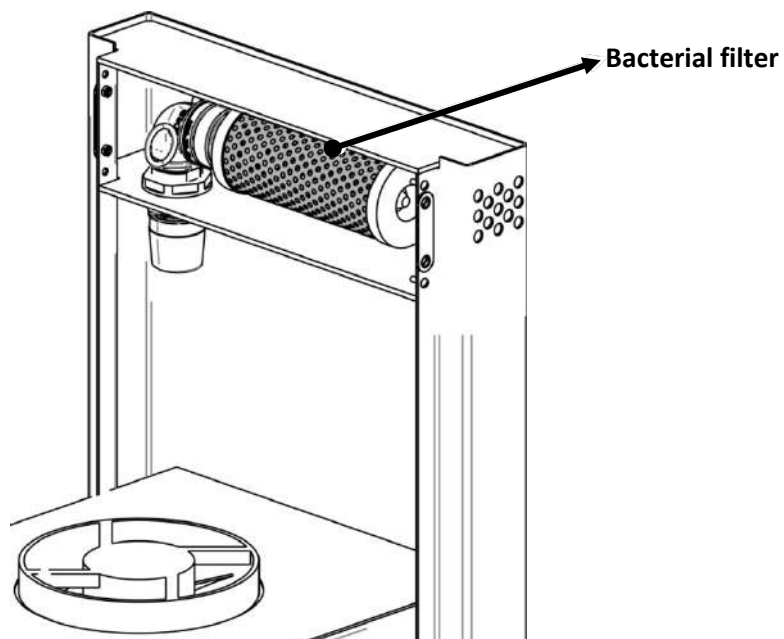

Figure 8.7.1.

The gases coming out of the suction unit contain bacteria. Since the equipment within the suction unit is designed only to remove liquid and particles, the bacteria present there are sucked through this system. For this reason, it is recommended to install a bacterial filter in the exhaust system and change this filter at least **once a year**.

8.8 Replacement of the autonomous container for secretions

During disinfection, the container for secretions must be cleaned and washed with hot water and a disinfectant. The disinfectant must be low-foaming and approved by the manufacturer, in accordance with applicable national legislation, to be suitable for the relevant surfaces and materials.

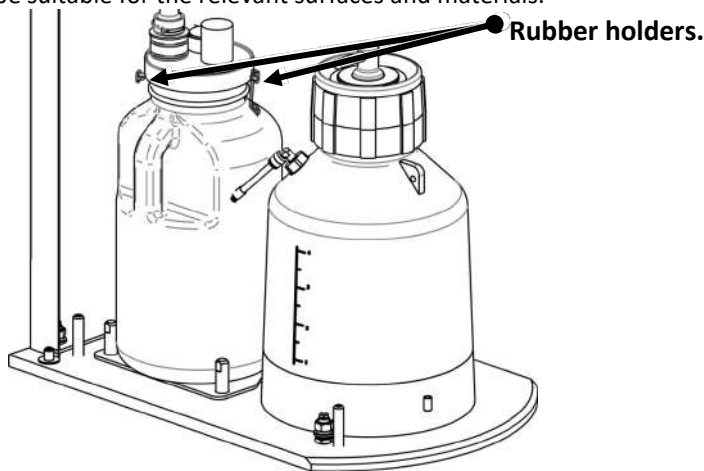

Figure 8.8.1

When the tank is filled to the level of the upper sensor, a constant sound signal is activated in the hydroblock. In this case, the exhaust unit will not turn on, and water will not be supplied to fill the cup and to rinse the cuspidor. The autonomous tank needs to be cleaned or replaced:

To do the same:

- turn off the unit;
- disconnect the connectors of the cable No. 16-2 connected to the container sensors (if necessary);
- remove the rubber holders from the cover of the container and the cover itself;
- clean or replace the container;
- install the cover and rubber holders.
- The unit is ready for operation

8.8.1 Work with filling the cup and rinsing the cuspidor

When working with filling the cup and rinsing the cuspidor, pay special attention to the following:

- **appearance of a sound signal** indicates that the autonomous container is full;
- **lack of rinsing of the spittoon and filling of the cup** indicates that the autonomous container is full.

To restore the full functioning of the dental unit, free the autonomous container from liquid or replace the container (item 8.8 "Replacing the autonomous container for secretion").



It is forbidden to pour liquid into the spittoon when filling the autonomous container (Figure 8.8.1.1). Otherwise, the equipment may malfunction due to overflow of liquid from the autonomous container.

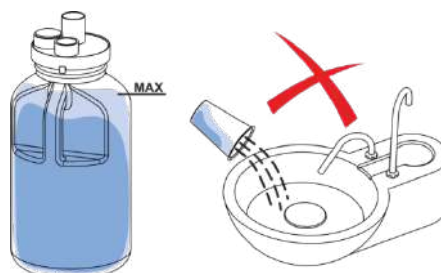

Figure 8.8.1.1



PC "Galit" is not responsible for equipment breakdowns caused by non-compliance with equipment operation requirements.

8.9 Separator

8.9.1 Separator "CS1"

Separator CS1 of the company "Durr Dental" is a fully automatic device, non-disassembleable. Flushing and cleaning is carried out during the cleaning of the entire aspiration system.



Figure 8.9.2.

VARIO

Vario Durr Dental rinsing device is intended for use in an aspiration system. The device is connected to the water supply system, which allows you to constantly add water to the aspiration system (0.1-0.2 l/min). The constant supply of water prevents any formation of highly soluble plaque and occurrence of blood coagulation in the system.

8.9.2 Maintenance of separator CS1 of the aspiration system with collector of solid particles

1. **Separator CS1** of company "Durr Dental" is a fully automatic device, non-disassembleable. Rinsing and cleaning is carried out during cleaning of the entire aspiration system.

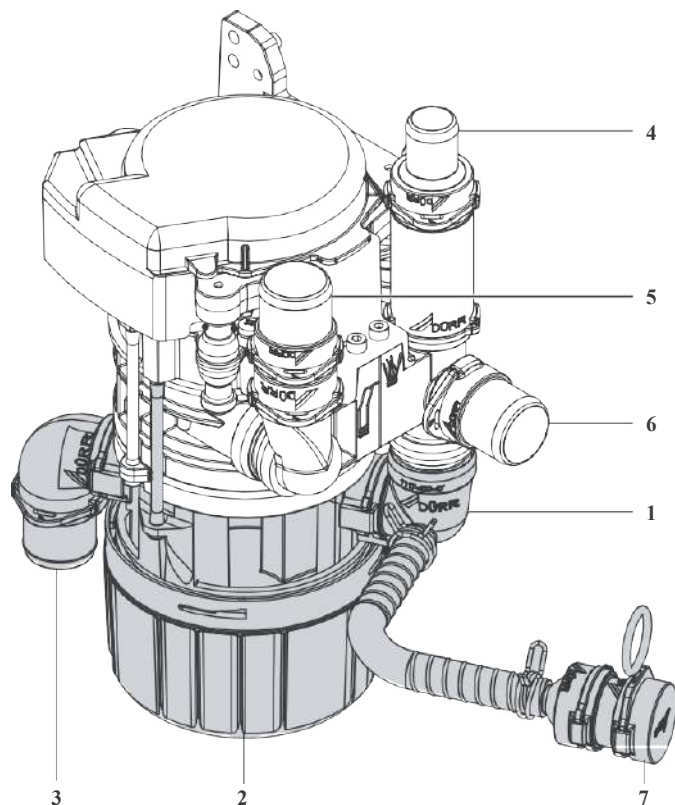

- 1 - hose inlet;
- 2 - solid particles collector;
- 3 - connection of the sewage system;
- 4 - air connection;
- 5 - connection of the suction system;
- 6 - connecting the drain from the cuspidor;
- 7 - emergency drain.

Figure 8.9.1.

2. Maintenance of the solid parts collector.



ATTENTION! It is recommended to use waterproof gloves when replacing the solid parts collector, in order to avoid risk of contamination.

Maintenance consists of checking the solids collector at least once a week, followed by replacement or cleaning of the collector.

When cleaning the solid parts collector, replace the filter with a new one.

Wear of the O-ring in the manifold can lead to leaks, so the O-ring must be replaced when necessary.

Consumables:

Solid particles collector with backing ring, with 5 filter cartridges - order number: 7117-034-00

Backing ring for solid particles collector, with 10 filter cartridges – order number: 7117-035-00

3. Faults.

If the solids collector is not cleaned or replaced in a timely manner, it will overflow, which can cause system blockage. When the collector is full, a noise can be heard in the separator or there will be a return of the flow of liquid to the cuspidor. If this situation occurs, use the emergency drain and then replace the manifold without risk of spillage or overflow.



Detailed instructions for operation and maintenance are given in the operational documentation for the separator.

8.9.3 Separator of “Cattani” company

It is necessary once a week:

- disconnect nozzles with hoses from the cover **1** of the separator;
- disconnect the electrical cable of the separator from A120M water unit board;
- remove separator cover **1** from the separator housing **2**, having previously released the rubber fasteners **3**;
- pull out the separator housing from the holder **5**;
- clean and rinse the cover **1** of separator with electrodes and separator housing;
- make assembly of the separator in reverse order.

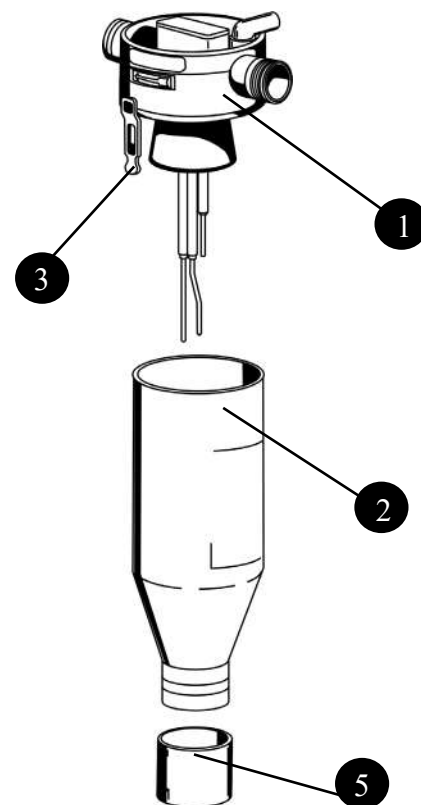
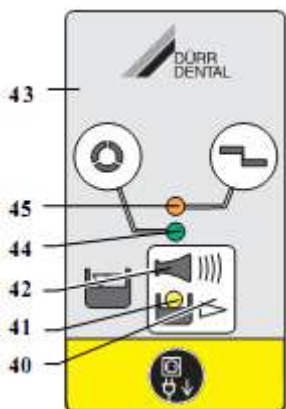

Figure 8.9.3.1.

8.9.4 Separator “CAS1”

8.9.4.1. Indication of Separator CAS1



Procedure of operation

Ready for operation

- GREEN indicator (44) is on

Amalgam container is filled up to 95%

- YELLOW indicator (41) is on
- GREEN indicator (44) is on and beep sounds.

At 95% filling, the sound signal can be switched off with the button (44). At the same time, the GREEN indicator (44) lights up and the separator is ready for further work. The YELLOW indicator is on to remind you to replace the amalgam container. Each time the main switch is switched on, indication of the filling level is repeated.



It is recommended to replace the amalgam container when it is 95% full.

Amalgam container is 100% full

- YELLOW indicator (41) is on
- ORANGE indicator (45) flashes and beeps 

At **100% filling level**, the sound signal can no longer be switched off by pressing the button (40). Replace the container.



In order to avoid infection, it is recommended to use waterproof gloves when changing the amalgam container.

Only after replacing the amalgam container the amalgam separator is “Ready to operation” again

Container is not installed

- ОРАНЖЕВИЙ індикатор (45) миготить і звучить звуковий сигнал. 

By briefly pressing the button (40), you can switch off the sound signal.

Switch Off (ВИКлючити) the device.

Insert the container.

Switch On (ВКлючити) the device.

The green indicator lights up "Ready to operation"

If, after installing the container, the orange indicator continues to light, there is a malfunction of the equipment - **notify the technician for troubleshooting.**

Engine failure

- ORANGE indicator (45)
GREEN indicator (44) flashes from time to time
- Beep sounds. 

By briefly pressing the button (40), you can switch off the sound signal.

When the button (40) is pressed for more than 2 seconds, the separator can be started again.

The green indicator lights up "Ready to operation".

If after repeatedly pressing the button (40) the signal is still lit, then there is a malfunction - notify the technician.

8.9.4.2. Coarse cleaning filter

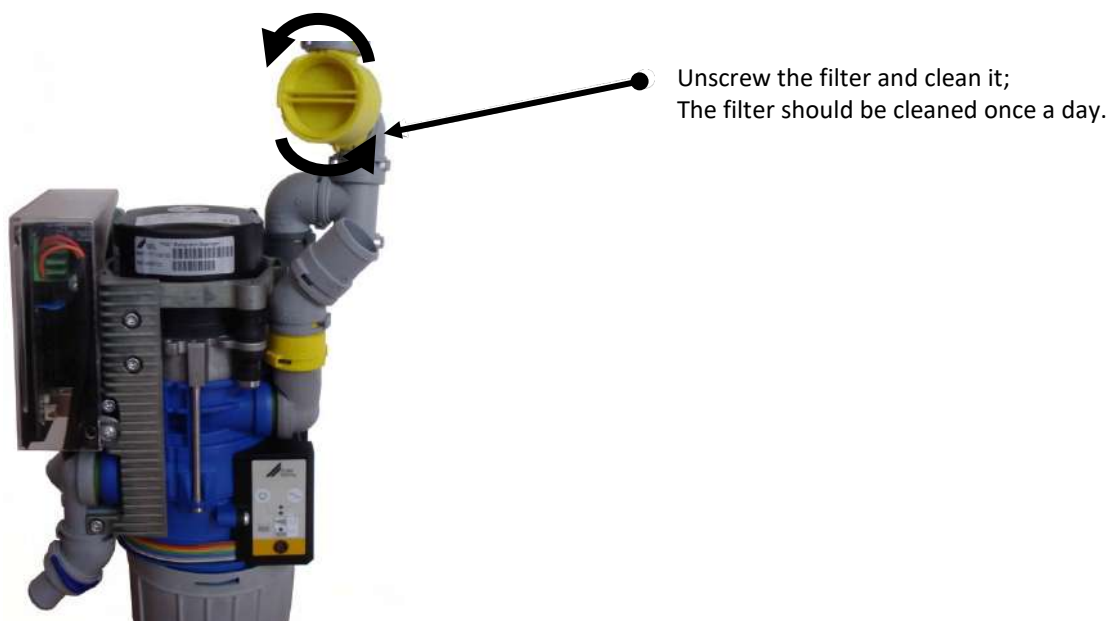

Figure 8.9.4.2.1

8.9.4.3. Maintenance of separator CAS1. Replacing the container for collecting amalgam.

1. Cleaning of filter 0700-700-18.

To do this, you need to remove the fasteners and clean the inlet filter (replace if necessary).

2. Replacing the container for collecting amalgam.

- Switch off the "GALLANT-Console" main switch. (If you unscrew the container with amalgam and do not switch off the unit, the indicator flashes and the sound signal sounds);
- Turn the full container for amalgam over and take it down. Remove the contents of the container and wash with a detergent;
- Put the container in place, screw it tightly to stop. Switch on the main switch, the device is "Ready for operation ".

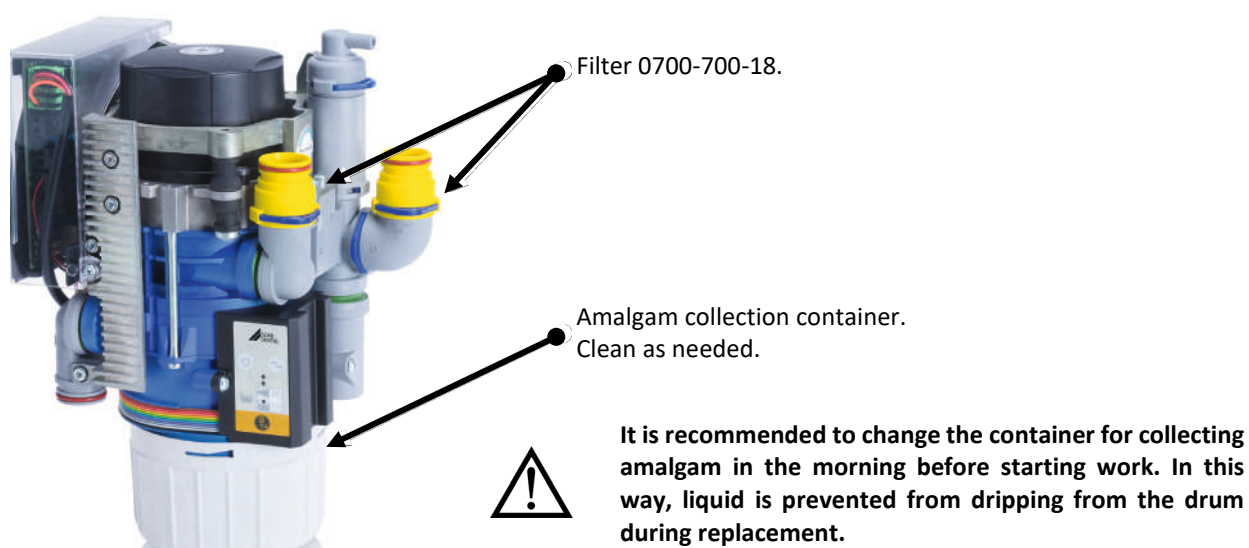
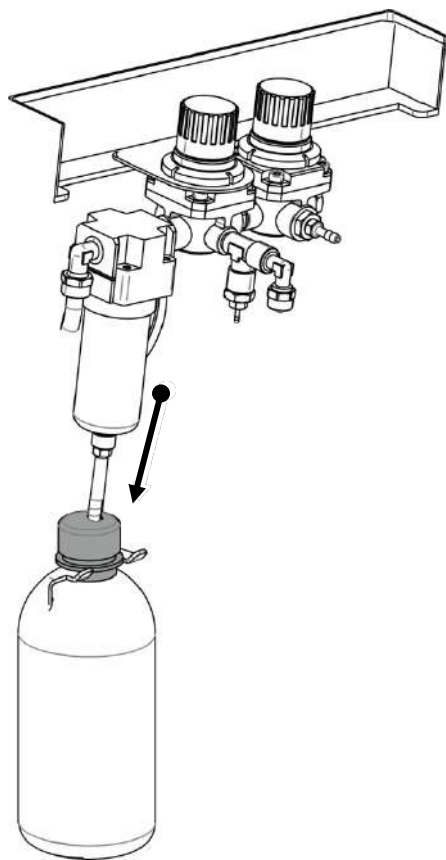

Figure 8.9.4.3.1

8.10 Draining condensate from the tank

Condensate is drained from the tank automatically. Figure 8.9.1 shows the flow of condensate from the flask to the condensate collection container.



Condensate formed in the tank enters the flask through the radiator. In the pressure flask, the valve opens and the collected condensate automatically flows into the container for collecting condensate.

Figure 8.10.1.

8.11 Maintenance of the aspiration system

The aspiration system includes:

- terminals of saliva ejector and dust extractor (the parts where the saliva ejector and dust extractor disposable pipes are installed);
- hoses of saliva ejector and dust instructor;
- the system connecting hoses;
- selection valve;
- cuspidor valve;
- filter (point 8.10.1) in housing;
- separator.

For simultaneous disinfection, cleaning, deodorization and care of suction dental systems, it is necessary to use means "Durr Dental GmbH & Co. KG" Orotol-Plus. Working solutions of these preparations carry out automatic long-term and safe cleaning. With daily use, they ensure the technical and hygienic level of operation of suction dental systems even in the presence of high contamination with microbes and significant contamination (saliva, amalgam and dental dust, blood, etc.).

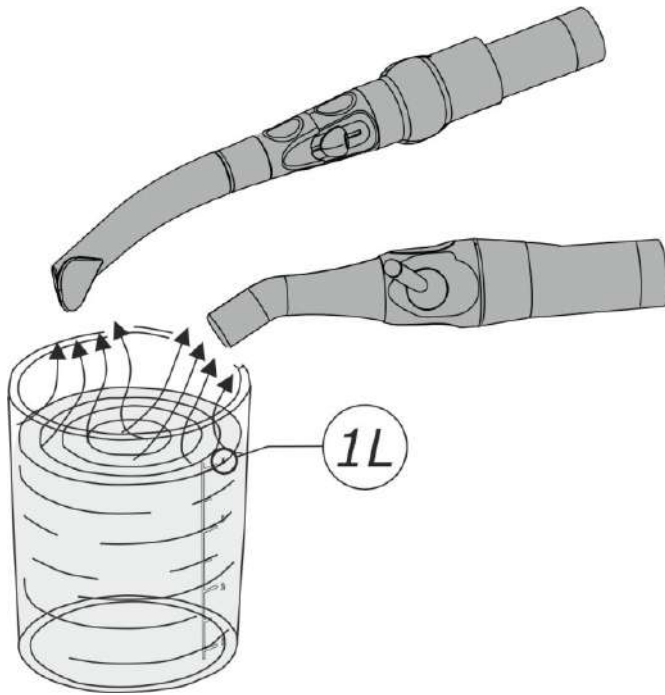

In accordance with the intensity of work of the suction dental system, disinfection and cleaning are carried out **1-2 times a day**. Mandatory disinfection and flushing of the system is carried out **at the end of the work shift**.

1. After receiving **each patient**, draw 1 litre of clean tap water by immersing the saliva ejector and dust extractor cannulas in the container with water.



2. Prepare solution of Orotol-Plus by diluting 20 ml of the concentrate in 1 litre of cold water.

Detailed instructions for use of the means "Durr Dental GmbH & Co. KG" are given in the methodical instructions for these products.

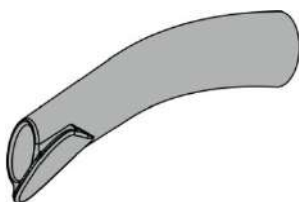

3. Remove the cannulas from the terminals of the handpieces.
Install the handpieces in the "OroCup" container".

4. When using the "OroCup" container of "Durr Dental GmbH & Co. KG" (order code 0780-350-00) the disinfection procedure lasts 4 minutes.

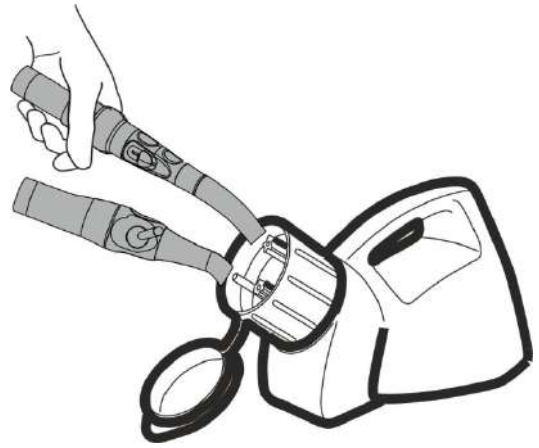

5. Pour the diluted solution of OROTOL into the cuspidor - 1 litre, pass through the cannulas of saliva ejector and dust extractor - 1 litre, fill the separator or valve of the cuspidor with the solution (depending on the unit version). Leave the product to act for 1 hour. Rinse the unit with running tap water for 3 minutes.



6. Leave the solution for disinfection for **-1 hour**.

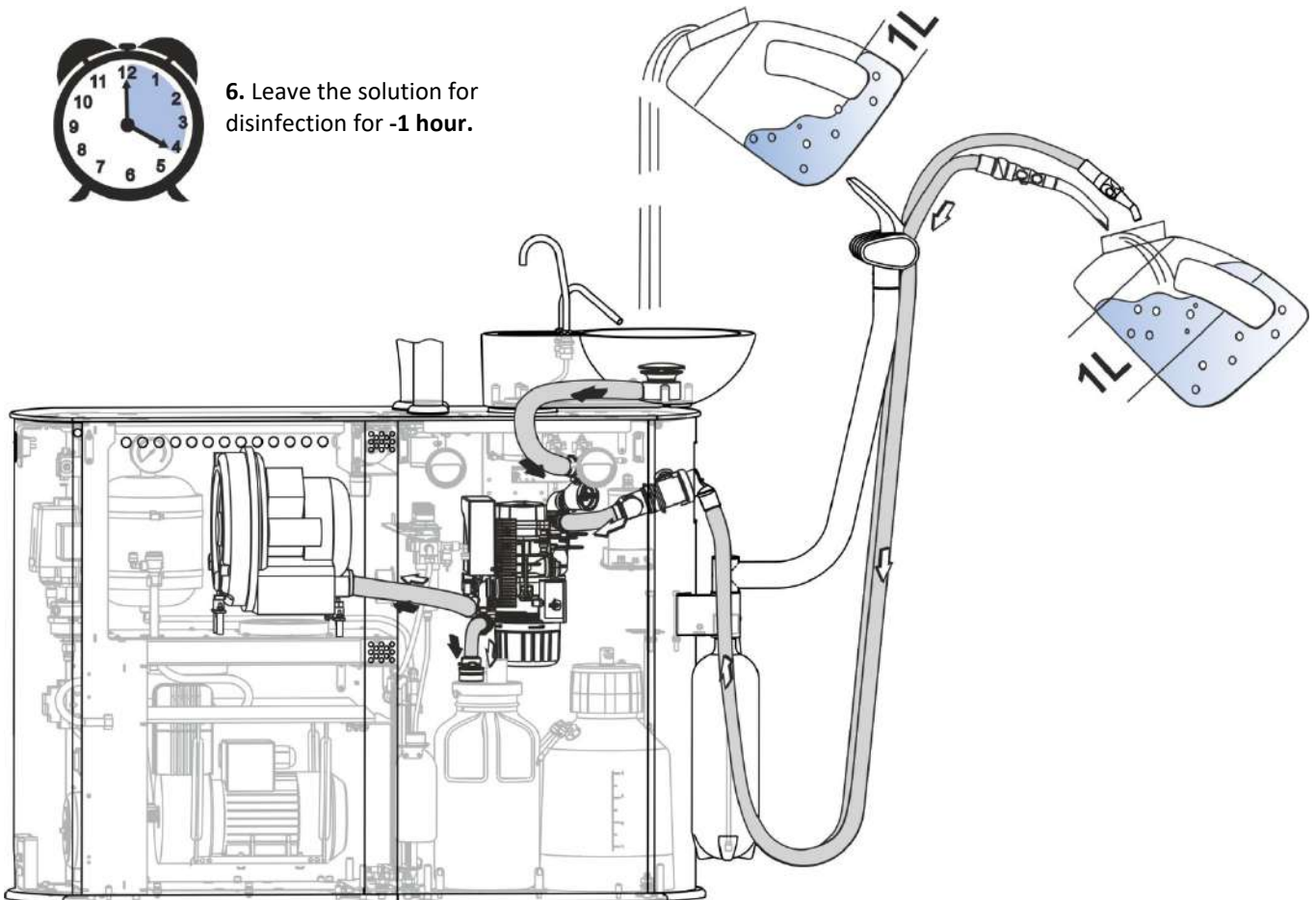

7. After the end of disinfection, dry the hoses, for this, remove the handpieces from the holders of the assistant table.

8.11.1 Cleaning the filter of the aspiration unit

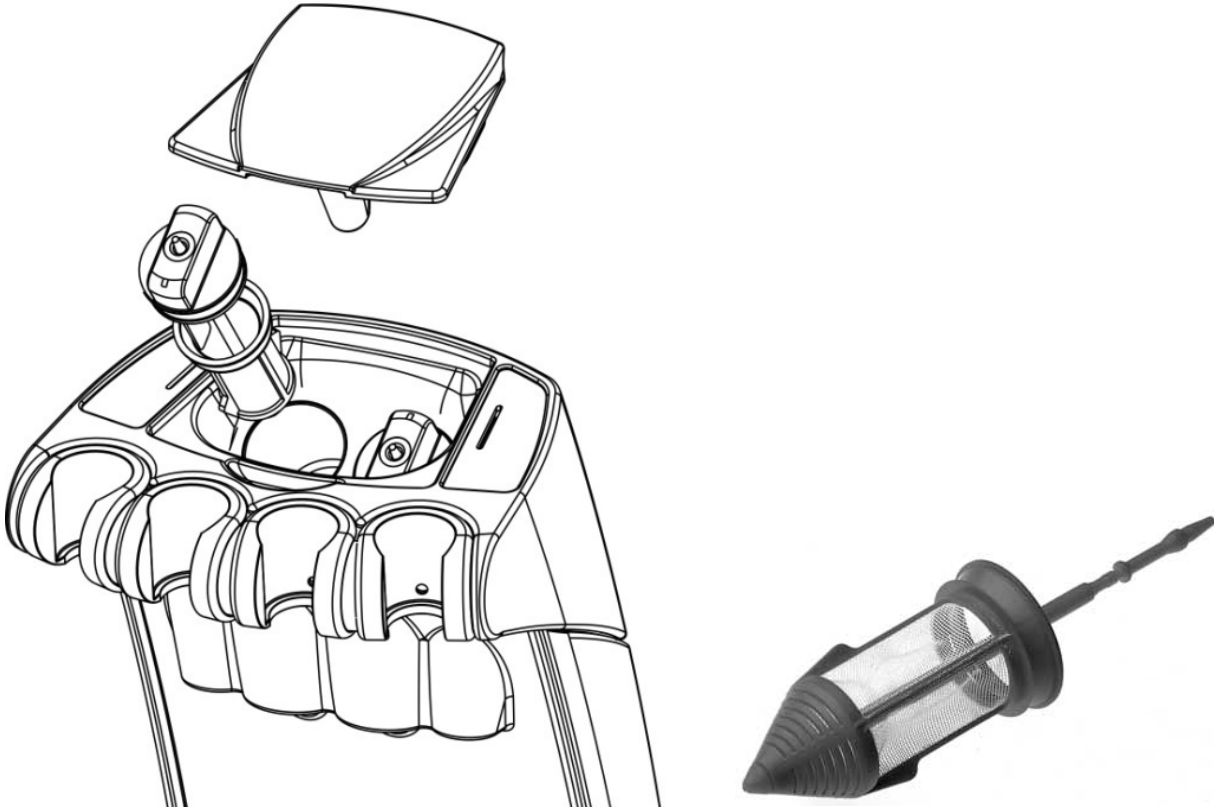

Once a day it is necessary to do as follows:

- open the filter cover of the aspiration unit by pulling it towards you;
- pull out the aspiration block filter;
- wash the filter using Durr Dental GmbH & Co. KG" OROTOL-Plus or neutral detergents;
- assemble the filter of the aspiration unit in the reverse order.



WARNING! The manufacturer guarantees reliable operation of suction dental systems only when using Durr Dental GmbH & Co. KG" OROTOL-Plus.
The use of foaming detergents for cleaning and disinfection of suction dental systems is strictly prohibited.

8.12 Thermal switch of the fan of the compressor compartment



The thermal cut-out switch is under life-threatening voltage.
To protect against electric shock, the thermal cut-out switch is protected by a cover.

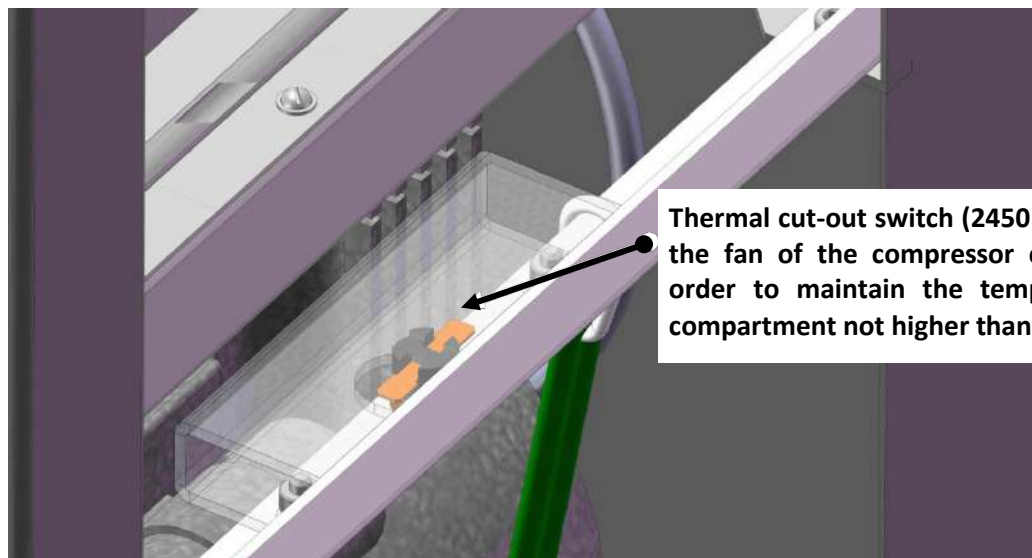

Thermal cut-out switch (2450 RH F) for on/off the fan of the compressor compartment in order to maintain the temperature in the compartment not higher than 40°C.

8.13 Replacement of fuse links



ATTENTION! Before replacing the fuse links, switch off the unit - for this, switch off the main switch and pull out the plug of the unit power cable from the power outlet ~220V 50Hz.

1. Replacement of the network fuse links placed in the water unit, input block.

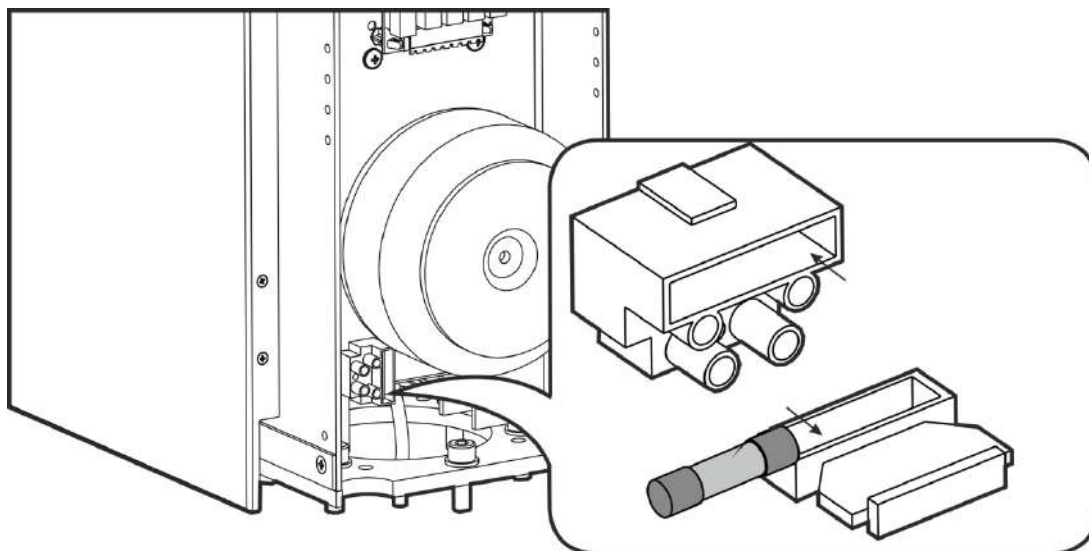

Figure 8.12.1

2. Replacement of fuse links of board A120/6.1.

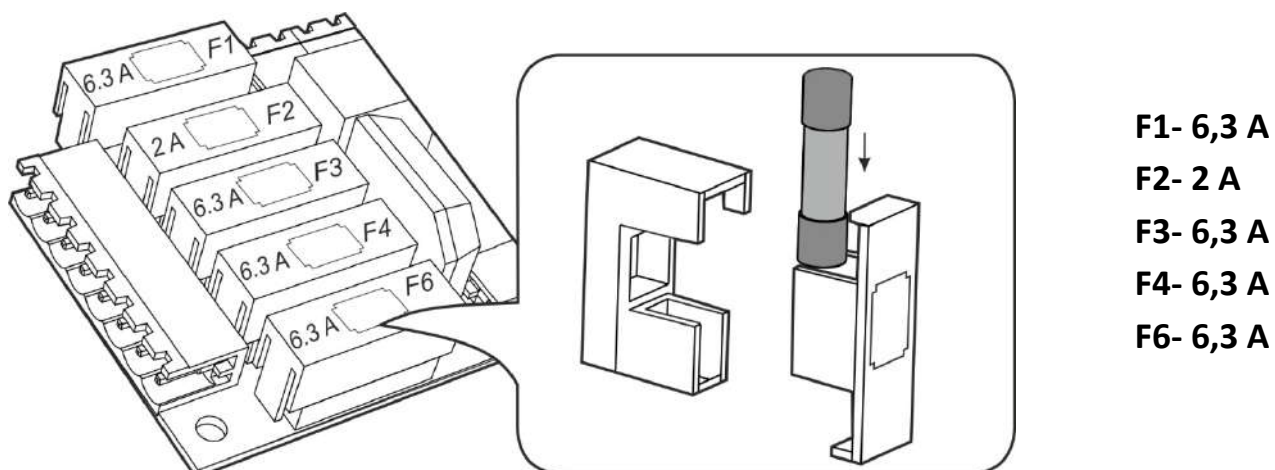

Figure 8.12.2

Designation and technical characteristics of fuse links

Designation	Value	Operating current	Protection	Location in the unit
Fuse link F1	T 6,3 AL	17A / 100ms	Common bus (0V) for the lamp	Water unit. Board A120/6.1
Fuse link F2	T 2 AL	5,4A / 100ms	~18V (powering the valves of the water unit)	Water unit. Board A120/6.1
Fuse link F3	T 6,3 AL	17A / 100ms	~27V (powering the doctor table)	Water unit. Board A120/6.1
Fuse link F4	T 6,3 AL	17A / 100ms	~24V (powering the doctor table)	Water unit. Board A120/6.1
Fuse link F6	T 6,3 AL	17A / 100ms	~24V (for additional devices)	Water unit. Board A120/6.1
Fuse link F1 (X1)	T 4 AL	10,8A / 100ms	Network ~220V	Water unit
Fuse link F2 (X2)	T 4 AL	10,8A / 100ms	Network ~220V	Water unit
Fuse link	2 x T 6,3A	17A / 100ms		At the base of the chair (see the instructions for operating the chairs ECO19/STING.)

Appearance and designation of board connectors A120/6.1.

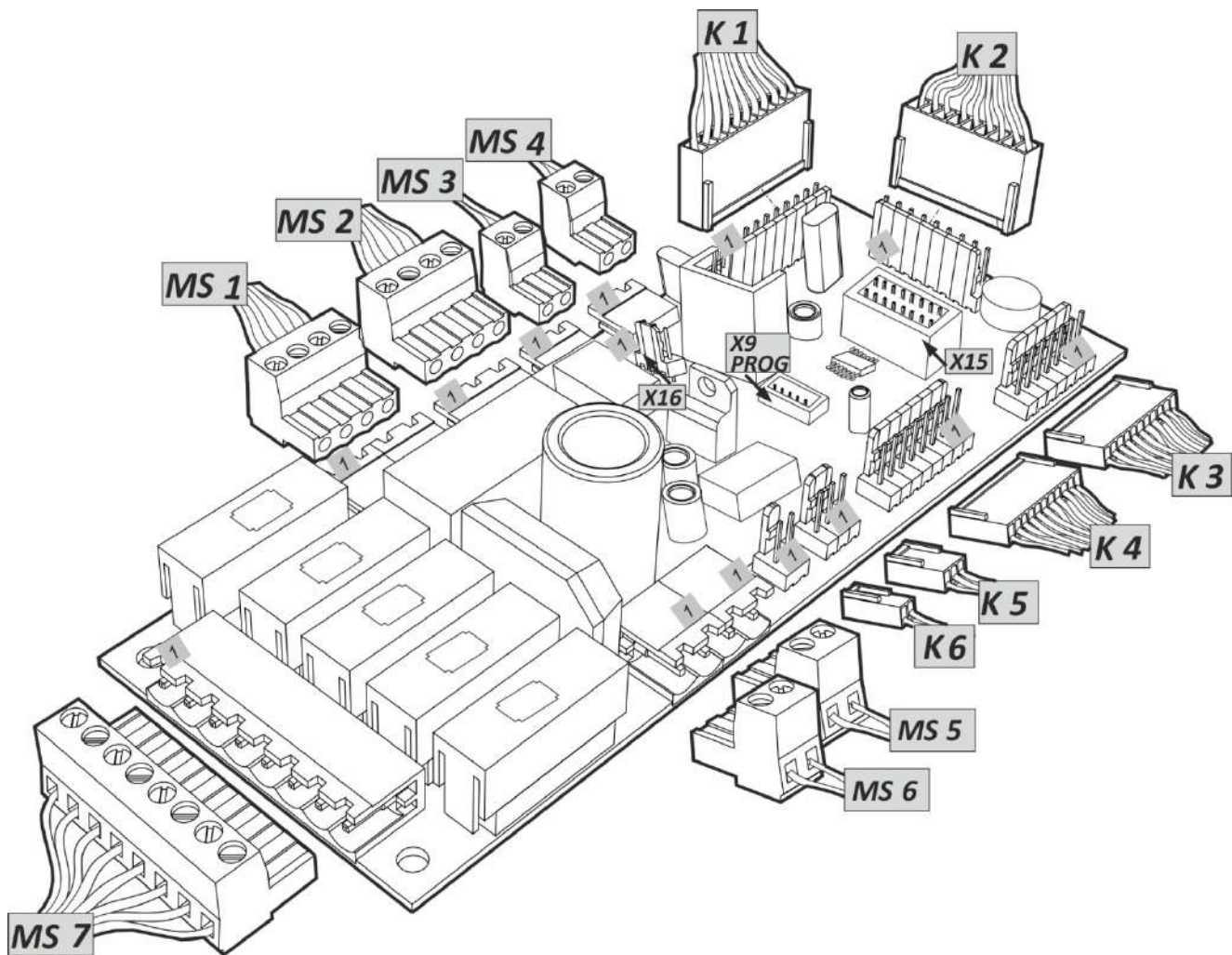

Figure 8.12.3

Functional assignment of contacts for socket connectors MS1-MS7, socket K1-K6, - board A120/6.1.

MS1 (for lamp)	
1	AC 0V
2	AC 10V
3	AC 13V
4	AC 18V
MS2 (for doctor table)	
1	AC 24V
2	AC 0V
3	AC 27V
MS3 (for aggregate control)	
1	Aggregate control AC 24V
2	Aggregate control AC 24V
MS4 (for aggregate control)	
1	Aggregate control Short Circuit
2	Aggregate control Short Circuit
MS5	
1	AC 24V On/Off
2	AC 24V On/Off
MS6	
1	AC 24V
2	AC 24V
MS7 (від силового трансформатора)	
1	AC 0V
2	AC 10V
3	AC 13V
4	AC 18V
5	AC 3V
6	AC 3Vcom
7	AC 24V
8	AC 24Vcom
K1 (signals of interaction with the doctor table)	
1	0V (com.)
2	Foot control
3	Rinsing
4	Cup
5	Reverse
6	Blowing
7	Spray
8	Potentiometer (+5V)
9	Potentiometer (ser.)
10	Light
11	Potentiometer (com.)

K2 (for foot control)	
1	0V (com.)
2	Foot control
3	Blowing
4	Spray
5	Potentiometer (+5V)
6	Potentiometer (ser)
7	Reverse
8	On
9	Potentiometer (com.)
K3 (solenoid valve of water unit)	
1	DC 24V
2	Valve of saliva ejector
3	Valve of bowl rinsing
4	Valve of cup
5	Valve of separator rinsing
6	DC 24V
7	Valve of unit selection
K4 (control from the assistant table)	
1	0V (com.)
2	Saliva ejector control
3	Rinsing control
4	Cup control
5	Aggregate control
6	Aggregate control
7	Coagulator control
8	Coagulator control
K5 (separator sensors)	
1	Sensor 3
2	Sensor 2
3	Sensor 1
K6 (for coagulator and others)	
1	Control Short Circuit
2	Control Short Circuit

X9 "PROG"	
Connector for programming PIC 16F 886 microcontroller	
X15 (for orthodontic unit)	
1	24V DC
2	Proportional valve of the main pneumatic outlet channel
3	Pneumatic outlet spray valve
4	Pneumatic outlet blowing valve
5	Micromotor cooling valve
6	Micromotor spray valve
7	Micromotor blowing valve
8	Pneumatic outlet holder
9	Button for illumination of pneumatic outlet
10	Common bus (0V)
11-	Micromotor reverse On/Off
12	
13-	Pneumatic outlet illumination On/Off
14	
X16 for powering the proportional valve of the pneumatic outlet in the orthodontic unit	
1	(7÷21)V DC – smoothly adjustable with a foot control
2-3	multi-function foot control potentiometer

8.14 Recommended maintenance frequency

Subassemblies	Periodicity
• Cuspidor bowl filter of the water unit.	after receiving the patient
• Exhaust air filter of the pneumatic outlet.	once a month
• Dust extractor filter	at the end of the work
• Saliva ejector filter	at the end of the work
• Siphon flushing	at the end of the work
• Hoses of dust extractors and saliva ejectors	at the end of the work
• Condensate drain	at the end of the work
• Curing lamp (sterilization of the optical fiber, disinfection of external surfaces)	after receiving the patient
• Turbine handpieces (sterilization, cleaning and lubrication)	after receiving the patient
• Electric micromotor handpieces (sterilization, cleaning and lubrication)	after receiving the patient
• Electric micromotor (disinfection of external surfaces)	after receiving the patient
• Piezoscaler (sterilization or disinfection of external surfaces)	after receiving the patient
• Dental syringe (sterilization or disinfection of external surfaces)	after receiving the patient
• Cleaning and disinfection of external surfaces of the unit, cleaning of the dental lamp	at the end of the work
• Disinfection. Flushing the internal channels of the hoses of the dental unit	after receiving the patient

8.15 Technical malfunctions and methods of their elimination



ATTENTION! Before carrying out troubleshooting work, turn off the UNITn: pull out the plug of the power cable of the UNIT from the power outlet ~220V 50Hz, turn off the main switch.

Malfunction	Reason	Method of elimination
There is no light indication when the switch is in the on position.	There is no voltage in the power network.	Check presence of voltage in the electrical network.
	Burned fuse links.	Replace the fuse links with serviceable ones from the delivery set.
There is no regulation of the water-air mixture.	Defective water-air mixture adjustment block.	Repair the block.
The lamp does not work when the switch is on.	The lamp bulb has burned out.	Replace the lamp.
The saliva extractor (water) does not work.	Insufficient pressure in the water supply system.	Check pressure in the water supply system.
	Clogged external water filter.	Rinse the external water filter.
Leakage of air or water.	The tightness of the joints is broken	Eliminate leaks.
There is no water supply through the dental syringe.	Clogged syringe tip channel.	Clean the water supply channel of the handpiece with a mandrel from the turbine handpiece delivery kit.
The fan of the compressor compartment does not work	Defective thermal switch TN63	Check the connection and serviceability of the thermal switch (2450 RH F)

8.16 Disinfection. Flushing the internal channels of the hoses of the dental unit



1. . Disconnect the container of the distilled water system DWS.
Drain the water. Screw the empty container.

2. Remove the handpieces from the instrument holders.

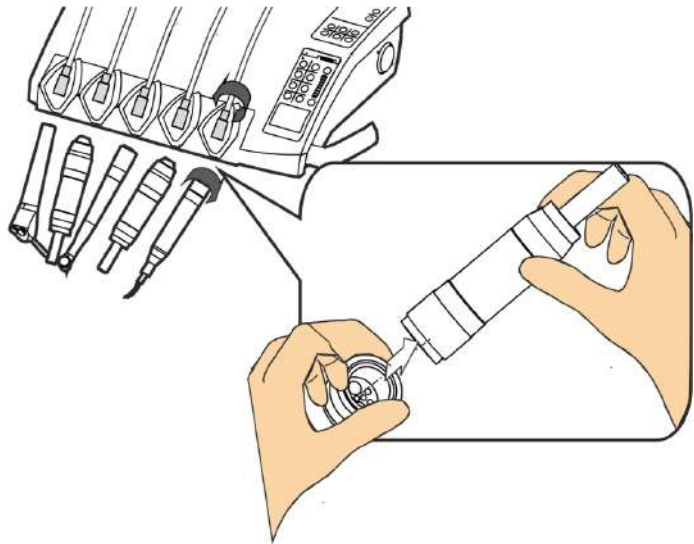

3. By the regulator located at the bottom of the doctor table unscrew the air supply AIR.
Press the SPRAY button on the control panel of the doctor table.

Press the foot control so that the water comes out and blow air channels of hoses.

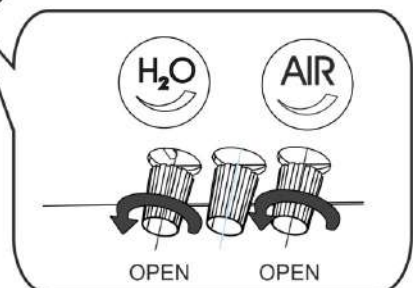
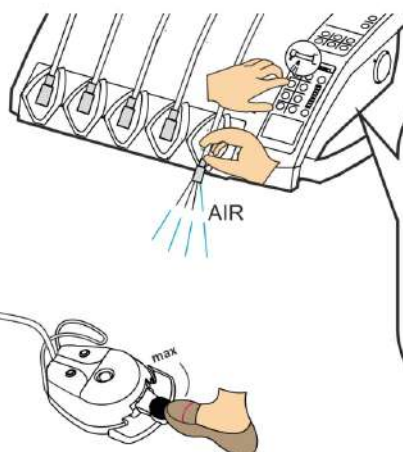

WARNING! The DWS/water pipe switch (if present in the unit) must be in the DWS position during disinfection.



4. In the distilled water system container pour 20 ml of a 3% solution of hydrogen peroxide per 1 litre of the distilled water.

5. Fill all instruments with hydrogen peroxide solution. Press the foot control. Press the button on the control panel of the doctor unit. So that the solution reaches the instruments.

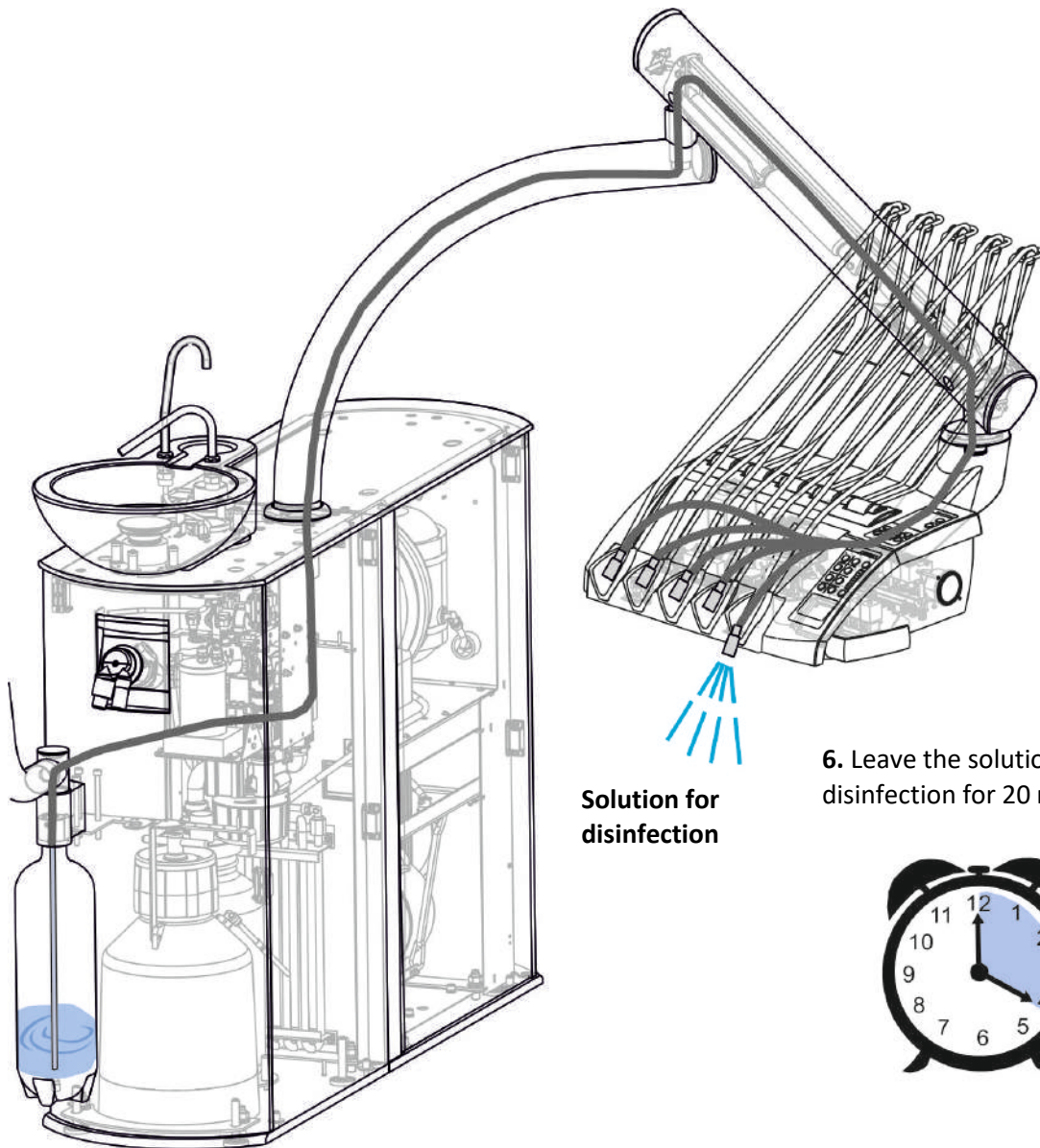

6. Leave the solution for disinfection for 20 min.



20MIN

7. Blow out the air channels of the hoses again to clean them from the disinfectant solution according to point 3.



ATTENTION! Do not leave the hydrogen peroxide solution in the unit for more than 1 month.

9 Electromagnetic Compatibility (EMC) (MEK 60601-1-2)

Important operating characteristics during EMC testing

№	Function check	Normative data
1.	Checking the adjustment of rotation frequency of the instrument with a micromotor, rpm.	The function is being tested "regulated / not regulated"
2.	Checking the adjustment of rotation frequency of the air turbine instrument, rpm.	The function is being tested "regulated / not regulated"
3.	Switching on reverse, spray, negatoscope, lamp	The function is being tested "switches on / does not switch on"
4.	Checking operation of the dental syringe	The function is being tested "switches on / does not switch on"

"GALLANT AUTONOME PRO" installation locations sensitive to electrostatic discharge are marked with warning symbols and inscriptions:



It is forbidden to touch the contacts of the connections that have a warning symbol on the marking about sensitivity to electrostatic discharge.

Precautions must be taken before connecting to these connections.

Manufacturer's manual and declaration (electromagnetic radiation)			
The dental unit "GALLANT AUTONOME PRO " is intended for use in the following electromagnetic environment. The customer or user is obliged to ensure operation under the following environmental conditions.			
Radiation test	Conformity	Electromagnetic environment (recommendations)	
RF radiation CISPR 11	Group 1	Dental unit "GALLANT AUTONOME PRO " uses high-frequency energy only for its internal functioning. Therefore, its high-frequency radiation is insignificant and is unlikely to cause any interference in the electrical equipment located nearby. Dental unit "GALLANT AUTONOME PRO " is intended for use in residential and non-residential premises, as well as in premises connected to a low-voltage power network, which is supplied to the premises for domestic use.	
RF radiation CISPR 11	Class B		
Harmonic radiation MEK 61000-3-2	Class A		
Fluctuation voltage/ flicker MEK 61000-3-3	Conforms		

Manufacturer's manual and declaration. Electromagnetic immunity			
Dental unit "GALLANT AUTONOME PRO " is intended for use in the following electromagnetic environment. The user of the dental unit "GALLANT AUTONOME PRO" is obliged to ensure operation in the same electromagnetic environment.			
Immunity test	Test level MEK 60601	Compatibility level	Electromagnetic environment (recommendations)
Electrostatic discharge (ECP) MEK 61000-4-2	±6 kV, contact discharge ±8 kV, air discharge	±6 kV, contact discharge ±8 kV, air discharge	The floor should be made of wood, concrete or ceramic tiles. If the floor is covered with a synthetic coating, then the relative humidity should be at least 30%.
Short-term impulse disturbances MEK 61000-4-4	±2 kV for the power line ±1 kV for line in/out	±2 kV for the power line ±1 kV for line in/out	Requirements for the electrical network as a power source are the same as for medical premises.
Impulse disturbances of great energy MEK 61000-4-5	±1 kV between lines ±2 kV between lines and ground	±1 kV between lines ±2 kV between lines and ground	Requirements for the electrical network as a power source are the same as for medical premises.
High-energy impulse disturbances Voltage dips, short-term voltage interruptions and changes in the mains supply voltage MEK 61000-4-11	<5% UT (voltage drop UT >95%) for 0.5 period 40% UT (voltage drop UT 60%) for 5 periods 70% UT (30% UT voltage drop) for 25 periods <5% UT (UT voltage drop >95%) for 5 seconds	<5% UT (voltage drop UT >95%) for 0.5 period 40% UT (voltage drop UT 60%) for 5 periods 70% UT (30% UT voltage drop) for 25 periods <5% UT (UT voltage drop >95%) for 5 seconds	Requirements for the electrical network as a power source are the same as for medical premises. If uninterrupted operation of the "GALLANT AUTONOME PRO " dental unit is required, in case of interruptions in the power supply network, it is recommended to power the "GALLANT AUTONOME PRO " dental unit from an uninterruptible power source or batteries.
Magnetic fields with the frequency of the network MEK 61000-4-8	3 A/m	3 A/m	Requirements for the magnetic field of the industrial frequency must correspond to the values established for medical premises.
<p>*Note. U_T – change in network voltage before applying the test level.</p>			

Manufacturer's manual and declaration. Electromagnetic immunity			
Dental unit "GALLANT AUTONOME PRO " is intended for use in the following electromagnetic environment. The user of the "GALLANT AUTONOME PRO " unit is obliged to ensure operation in the same electromagnetic environment.			
Immunity test	Test level MEK 60601	Compliance level	Electromagnetic environment (recommendations)
<p>Кондуктивні радіозавади MEK 61000-4-6</p> <p>Випромінювальні радіозавади MEK 61000-4-3</p>	<p>3 В (середньоквадратичне значення) від 150 кГц до 80 МГц, крім діапазонів ПНМ^a</p> <p>3 В/м від 80 МГц до 2,5 ГГц</p>	<p>3 В</p> <p>3 В/м</p>	<p>The distance between the used portable or mobile RF communication equipment and any part of the "GALLANT AUTONOME PRO" dental unit, including cables, must be at least the recommended minimum distance, which is calculated from the formula for the corresponding part of the transmitter.</p> <p>Recommended distance:</p> $d = 1,2\sqrt{P}$ $d = 1,2\sqrt{P} \text{ (from 80 MHz to 800 MHz)}$ $d = 2,3\sqrt{P} \text{ ((from 800 MHz to 2.5 GHz)}$ <p>where P is the maximum output power of the transmitter in watts (W) according to the data of the transmitter manufacturer, and d is the recommended distance of the equipment in meters (m).b</p> <p>The strength of the field created by stationary radio transmitters is determined by electromagnetic research, ^a must be less than the compatibility level in each frequency range.^b</p> <p>Interference may appear near equipment marked with the following symbol:</p> 
<p>*Note 1. At 80 MHz and 800 MHz, the value for the upper frequency range applies.</p> <p>*Note 2. These recommendations do not apply to all situations. The propagation of electromagnetic waves is affected by absorption and reflection caused by structures, objects and people.</p>			
<p>^a The field strength generated by fixed transmitters, such as radiotelephone (mobile/wireless) base stations, land mobile radio stations, amateur radio stations, AM and FM radio broadcast transmitters, and television broadcast transmitters cannot be theoretically predicted with accuracy. In order to assess the electromagnetic environment affected by fixed radio transmitters, an on-site electromagnetic immunity study should be provided.</p> <p>If the measured values of the field strength at the place of operation of the "GALLANT AUTONOME PRO " dental unit exceed the compatibility level indicated above for this case, then the normal functioning of the "GALLANT AUTONOME PRO " dental unit should be checked for some time. If there are deviations from normal functioning, additional measures should be taken, for example, changing the placement of the dental unit "GALLANT AUTONOME PRO ".</p> <p>^b In the entire frequency range from 150 kHz to 80 MHz, the field strength must be at least 3 V/m.</p>			

Recommended safe distance between portable and portable radio communication devices and the equipment or system

The dental unit "GALLANT AUTONOME PRO" is intended for use in an electromagnetic environment in which radiated radio interference is controlled. The user of the "GALLANT AUTONOME PRO" dental unit can ignore electromagnetic interference if he observes the minimum distance between portable and mobile radio communication devices (radio transmitters) and the recommendations below, in accordance with the maximum output power of the radio communication equipment.

Standardized maximum output power of the transmitter, W	Distance depending on the frequency of the transmitter, m		
	From 150 kHz to 80 MHz $d = 1,2\sqrt{P}$	From 80 MHz to 800 MHz $d = 1,2\sqrt{P}$	From 800 MHz to 2.5 GHz $d = 2,3\sqrt{P}$
0,01	0,12	0,12	0,24
0,1	0,37	0,37	0,74
1	1,17	1,17	2,34
10	3,69	3,69	7,38
100	11,67	11,67	23,34

For transmitters whose maximum output power is not listed above, the recommended distance in meters (m) can be calculated using the formula applied to the frequency of the transmitter, where P is the maximum rated output power of the transmitter in watts (W) as specified by the manufacturer of that radio transmitter.

***Note 1.** At 80 MHz and 800 MHz, a higher frequency range is used.

***Note 2.** These recommendations do not apply to all situations. The propagation of electromagnetic waves is affected by their absorption and reflection from premises, objects and people.

10 Disposal

Disposal of dental units

According to directive 2002/96/EC, to prevent environmental pollution and injury during disposal, please follow the disposal laws.

It is possible that the dental unit is infected. Be sure to report this to the company so that appropriate security measures can be taken.

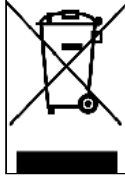

Uncontaminated plastic parts can be sent for plastic renewal.

Electronic boards and electronic components must be disposed of as electronic scrap.

Other metal parts (for example, the housing) must be disposed of as scrap metal.



Other components of the dental unit can be disposed of in accordance with the applicable local disposal instructions.

If the dental unit is not completely decommissioned, contact the manufacturer or seller of this dental unit.

**Appendix A1. Overall dimensions of autonomous dental unit
"GALLANT AUTONOME (model: AU)".**

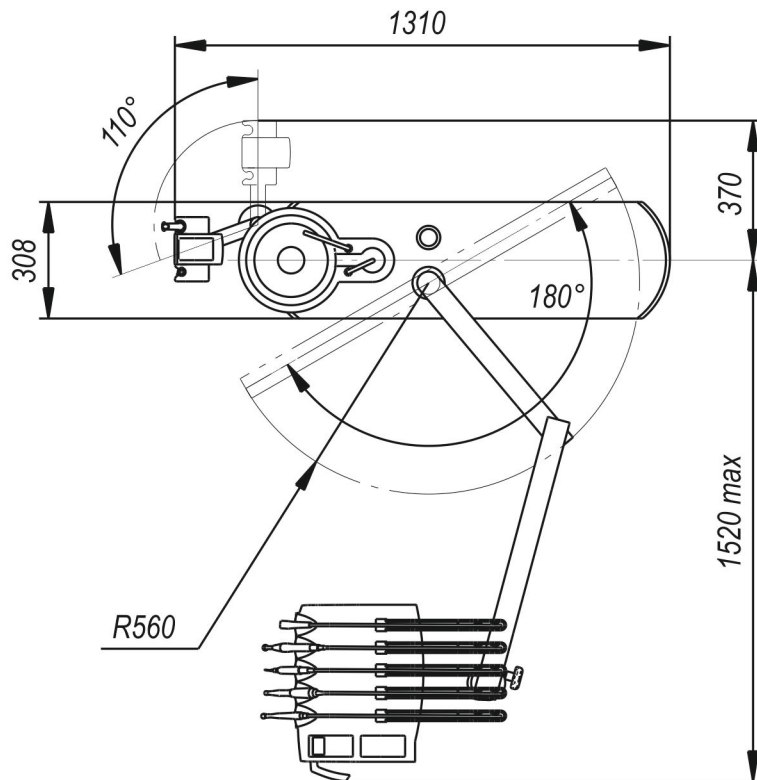
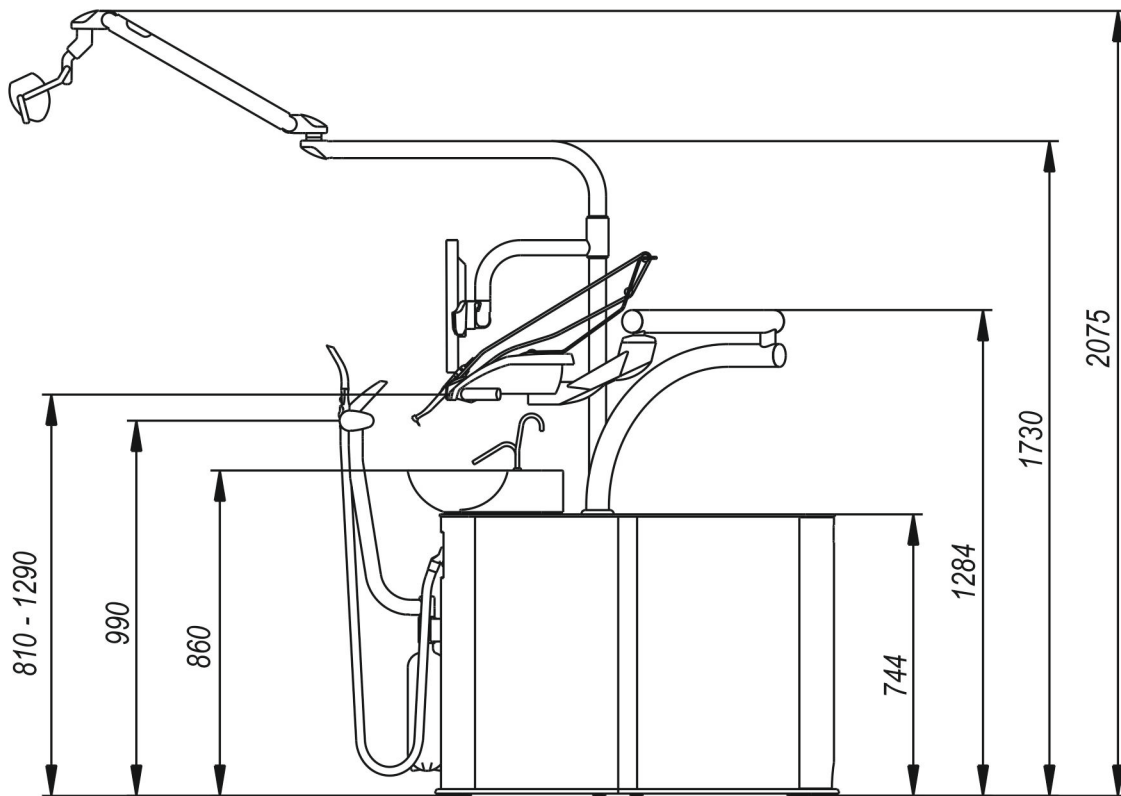

**Appendix A2. Overall dimensions of autonomous dental unit
“GALLANT AUTONOME (model: AL)”.**

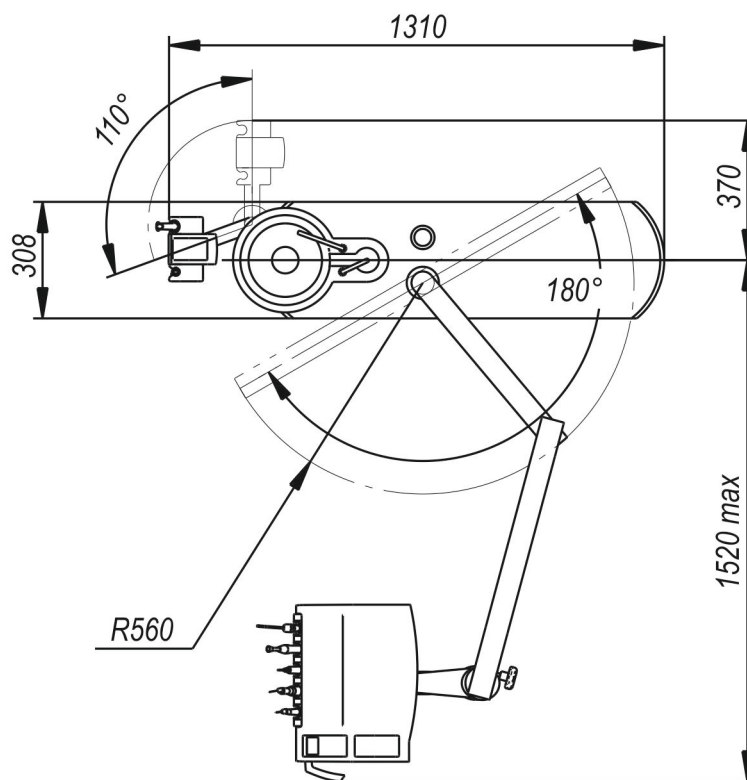
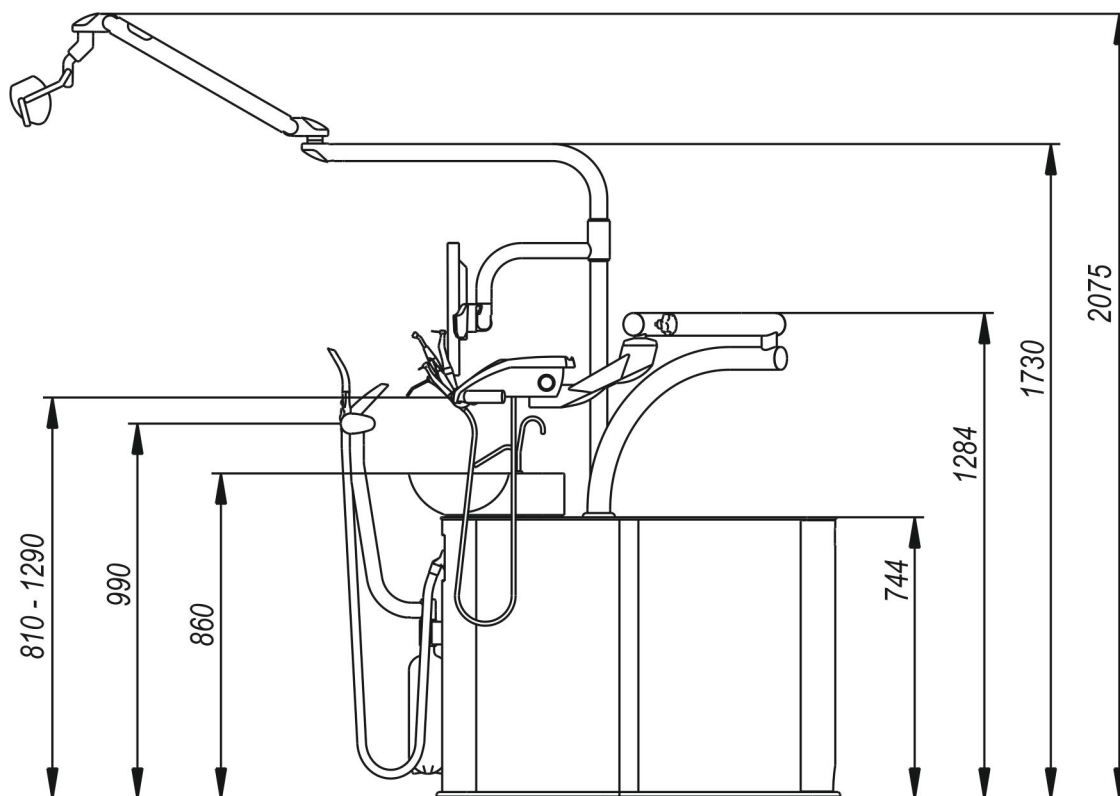

Appendix B. Checking parameters of dental equipment

product	Dental Unit "GALLANT Autonome PRO"
Serial Number	
date	

In the interests of personnel safety and the correct functioning of the equipment, it is necessary to conduct an electrical safety inspection of the dental unit every year in accordance with the IEC 60601-1-1 standard.

It is the owner's responsibility to arrange this inspection and to ensure that the technicians carrying out the electrical safety inspection of the equipment are highly qualified.

Table 1

No	Electrical safety parameter	Point of standard IEC 60601-1-1	Normative Index	Available Index (Filled in by a representative of the QD)	Available Index (Filled in by the person responsible for installing the dental unit)
1.	Checking the protective grounding, Ohm	i. 8.6	< 0,2		
2.	Checking the leakage current to the ground, μA	i. 8.7.4.5	< 500		
3.	Checking the leakage current to patient, μA	i. 8.7.4.7	< 100		

Representative of Quality Department _____ (_____)

Person responsible for installing the dental unit _____ (_____)

For your convenience, the form of the electrical safety equipment inspection report is provided below:

after 1 year

Check date	No	Electrical safety parameter	Normative index	Available index	Signature
	1	Checking the protective grounding, Ohm	< 0,2		
	2	Checking the leakage current to ground, μA	< 500		
	3	Checking the leakage current to patient, μA	< 100		

after 2 years

Check date	No	Electrical safety parameter	Normative index	Available index	Signature
	1	Checking the protective grounding, Ohm	< 0,2		
	2	Checking the leakage current to ground, μA	< 500		
	3	Checking the leakage current to patient, μA	< 100		

after 3 years

Check date	No	Electrical safety parameter	Normative index	Available index	Signature
	1	Checking the protective grounding, Ohm	< 0,2		
	2	Checking the leakage current to ground, μA	< 500		
	3	Checking the leakage current to patient, μA	< 100		

after 4 years

Check date	No	Electrical safety parameter	Normative index	Available index	Signature
	1	Checking the protective grounding, Ohm	< 0,2		
	2	Checking the leakage current to ground, μA	< 500		
	3	Checking the leakage current to patient, μA	< 100		

after 5 years

Check date	Nº	Electrical safety parameter	Normative index	Available index	Signature
	1	Checking the protective grounding, Ohm	< 0,2		
	2	Checking the leakage current to ground, μA	< 500		
	3	Checking the leakage current to patient, μA	< 100		

after 6 years

Check date	Nº	Electrical safety parameter	Normative index	Available index	Signature
	1	Checking the protective grounding, Ohm	< 0,2		
	2	Checking the leakage current to ground, μA	< 500		
	3	Checking the leakage current to patient, μA	< 100		

after 7 years

Check date	Nº	Electrical safety parameter	Normative index	Available index	Signature
	1	Checking the protective grounding, Ohm	< 0,2		
	2	Checking the leakage current to ground, μA	< 500		
	3	Checking the leakage current to patient, μA	< 100		

after 8 years

Check date	Nº	Electrical safety parameter	Normative index	Available index	Signature
	1	Checking the protective grounding, Ohm	< 0,2		
	2	Checking the leakage current to ground, μA	< 500		
	3	Checking the leakage current to patient, μA	< 100		

after 9 years

Check date	Nº	Electrical safety parameter	Normative index	Available index	Signature
	1	Checking the protective grounding, Ohm	< 0,2		
	2	Checking the leakage current to ground, μA	< 500		
	3	Checking the leakage current to patient, μA	< 100		

after 10 years

Check date	Nº	Electrical safety parameter	Normative index	Available index	Signature
	1	Checking the protective grounding, Ohm	< 0,2		
	2	Checking the leakage current to ground, μA	< 500		
	3	Checking the leakage current to patient, μA	< 100		

Appendix B. Dental Unit “GALLANT AUTONOME PRO”. Pneumatic Diagram

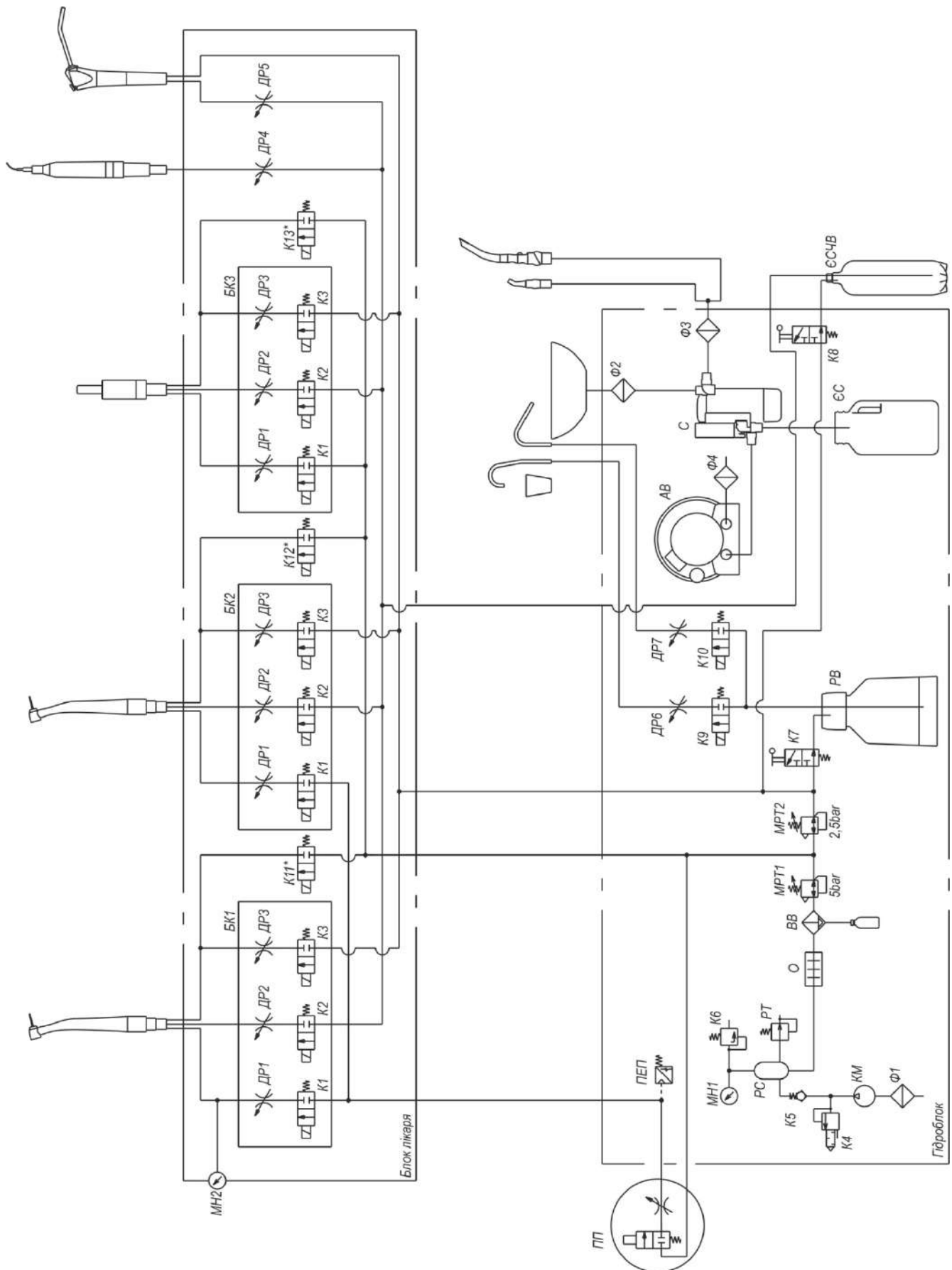

**Dental Unit "GALLANT AUTONOME PRO". Pneumatic Diagram.
Designations.**

Design.	Name	Code	Supplier
AB	Suction aggregate	1	V250 Durr Dental
БК1 ... БК3	Valve block	3	01-211P204-H0 Norgren
BB	Moisture separator	1	025200125 Ekom
ДР1 ... ДР3	Flow regulators	9	
ДР4	Flow regulator of scaler	1	
ДР5	Flow regulator of syringe	1	
ДР6	Flow regulator of cup filling	1	
ДР7	Flow regulator of cuspidor bowl rinsing	1	
ЄСЧВ	Distilled Water System container	1	ACF-543-02, 2л. USMedlink
ЄС	Container for secretions	1	203805 Cattani
K1	Main channel valve	3	
K2	Instrument cooling water valve	3	
K3	Instrument cooling air valve	3	
K4	Solenoid valve	1	330614 Jaksa
K5	Return valve	1	5150-40-02 Durr Dental
K6	Safety valve	1	112/1 TA8PED 1/4" 8 Bar Comex
K7,K8	Pneumatic switch	2	VAF-451-03 3Way USMedlink
K9, K10	Solenoid valve	2	2105NC24dc RPE
K11*...K13*	Blowing valve	3	V165B01 SIRAI
КП	Cuspidor valve	1	
КМ	Compressor	1	DK 50 DS Ekom
МН1	Manometer	1	M063-P12 Camozzi
МН2	Manometer	1	M043-R06 Camozzi
МРТ1, МРТ2	Pressure microregulator	2	M008-R00 Camozzi
О	Cooler	1	604021250 Ekom
ПП	Pneumatic foot control	1	FCF-251-01 USMedlink
ПЕП	Electropneumatic switch	1	244331 Faro
РВ	Container for water	1	Колба ОП-201-01 "Оріон 3"
РС	Tank	1	6102005 Comex
РТ	Pressure switch	1	MDR3/11-EA3-R3/ 6,3- 230-50 Condor-срс
С	Separator	1	CAS1 DurrDental
Ф1	Air filter	1	0880-001-00 DurrDental
Ф2	Coarse cleaning filter	1	0700-702-52 DurrDental
Ф3	Filter	1	0725-040-50 DurrDental
Ф4	Bacterial filter	1	7120-143-00 DurrDental

Approved by:
Director of PC "Galit"
Zolotyy V.P.
« » 20

11. General Warranty Conditions

1. PC "GALIT" provides a guarantee for products of its own production and products of other manufacturers, sold by the company, within 12 months from the date of sale, unless other terms are specified in the accompanying documentation for the products.

2. Warranty services are performed by free of charge repair or replacement of a defective part (subassembly). Cost of arrival of a service employee (or a technical specialist of a sales representative) to fulfill warranty obligations is a chargeable service according to the approved rates of the Service Centre of PC "GALIT". The decision on the method of repair is made by the service department of PC "GALIT", provided that the defects are caused by poor-quality assembly, or poor-quality materials and components within no more than 10 working days from receipt of the malfunction registration sheet. The term can be extended up to 30 working days if the malfunction requires sending the product for repair or analysis of the occurrence of the malfunction to a foreign company of the manufacturer.

3. A necessary condition for provision of warranty services is the presence of the following documents:

- 1) The present properly filled out Warranty service Coupon, which should be retained;
- 2) Completed and registered Product Installation Card, which should be sent to the manufacturer;
- 3) Completed and certified Fault Recording Sheet, which should be sent during the repair.

1. Acceptance of equipment for the performance of warranty services is carried out by the company GALIT at the address:

PC GALIT, 6E, 15 Kvitnya Str., vil. Baikivtsi, Ternopil region, 47711, Ukraine.

5. Buyer, on his own or through regional representatives of PC GALIT, at his own expense, ensures delivery of defective parts (subassemblies) with the Failure Registration Sheet to the above mentioned address. Defective parts (subassemblies) delivered to PC GALIT must be disinfected and sterilized (for products subject to autoclaving). Defective parts (subassemblies) must have original packaging that guarantees safe delivery to the service center.

6. The decision whether a defective component is covered by the warranty is up to PC Galit.

7. Execution of the Warranty services for overall equipment at the place of installation is provided by regional representatives of the service department of PC GALIT, or technical specialists of sales representatives through whom the equipment was purchased. Condition for the technician's visit to the place of installation of the equipment is a properly filled out and certified malfunction registration sheet and sent to the address of the regional representative of PC "Galit".

8. The Warranty does not apply to:

- products with damaged control seals that prevent unauthorized intervention;
- products damaged during transportation or storage;
- products in which arbitrary intervention or arbitrary modifications have been carried out;
- products with defects caused by violation of operating instructions;
- products, in case of non-fulfilment of the requirements for care and maintenance according to the operating instructions (including the materials used and the periodicity of routine work), or other accompanying documents;
- defects in the operation of products and defects caused by non-compliance with the requirements of accompanying documents regarding networks of compressed air, drainage (sewage), electricity and water supply;
- parts and assemblies, the defects of which are caused by natural wear, mechanical damage or the action of chemicals not provided for in the accompanying documents, during operation;
- light bulbs, micromotors, tips, turbines and other tools;
- lamps of shadowless and surgical lamps;
- all types of electric fuse links;
- nozzles of pneumatic and ultrasonic scalars.
- LEDs of curing lamps and lights.

9. The warranty conditions do not provide for periodic maintenance and routine work, which the user of the equipment must perform independently in accordance with the operating instructions for the products.

10. In the case of an unjustified request for warranty service, the Buyer is obliged to compensate for all expenses of PC "Galit" (or a sales representative) related to the arrival of a technician, according to the approved prices of the Service Center. In the event of the Buyer's refusal of compensation, the warranty for this product is removed. The decision on the validity of the appeal is made by PC Galit (or its sales representative).

Form №2-warranty

Manufacturer : Private Company "GALIT"
 Identification code by ЄДРПОУ: 30938037
 Address: 6Є, 15 Kvitnya Str., vil. Baikivtsi, Ternopil region, 47711, Ukraine
 Telephone No.: (0352) 43 38 07

WARRANTY COUPON

Valid after completion

To be filled in by Manufacturer-enterprise	
Dental equipment	GALLANT AUTONOME PRO Model
Factory №	Date of manufacture
<p>Representative of Quality Dpt. of Manufacturer-enterprise</p> <p>_____ (Quality Department stamp)</p>	
<p>Address for submitting claims to the quality of work: PC "GALIT", 6Є, 15 Kvitnya Str., vil. Baikivtsi, Ternopil region, 47711, Ukraine Tel. (0352) 43 38 07</p>	
To be filled in by trade enterprise	
Date of sale	Sales clerk
_____ (day, month, year)	_____ (signature or stamp)
Shop stamp	

The number under which the product is registered under warranty	Registration date	Full name, address, phone number of the consumer	Product name and serial number. Factory number of the component product, component part	The nature of the shortcomings	Remarks of the performer during the acceptance of the goods for repair	Repair deadline	Date and signature of the consumer on receipt of the goods after repair

COUPON for putting into operation within 12 months of the warranty period of operation

Valid after filling

The COUPON for putting into operation the dental unit "GALLANT AUTONOME PRO" must be sent to the address of the company "Galit" within 10 days from the moment of installation

=====

Regional representative	
Dental Unit User	
Dental Unit GALLANT AUTONOME PRO	
Model	
Factory №	
Date of Manufacture	
Date of putting the dental unit into operation	
Address of the Dental Unit location:	
Postal code of the city	
City	
Street	
Building	
Apartment (Office)	
Signature and full name of the person or service department that have installed and connected the dental unit	
Contact telephone No.	
Signature and full name of the dental unit owner to confirm the dental unit putting into operation	
Contact telephone No.	

=====

COUPON for putting into operation the "GALLANT AUTONOME PRO" DENTAL UNIT
 (*reverse side*)

Composition of the dental unit

NAME OF COMPLETING PARTS	FACTORY NUMBER
Foot Control	
Lamp	
Micromotor	
Micromotor	
Micromotor	
Syringe	
Syringe	
Curing Lamp	
Coagulator	
Scaler	
Separator	
Water Unit Heater	
Doctor Table Heater	
Monitor	
Camera	
Cuspidor valve	
Compressor	
Suction aggregate	

The person responsible for packing _____ (_____)

Representative of Quality Department _____ (_____)