

Dental Unit
GALLANT PRO (model: DU/DL)

OPERATING MANUAL

Version 1_ENG_2022



GALIT

Ukraine 47711, Ternopil region, Baykivtsi village, 15 Kvitnya str., 6E
tel:+420775471378

E-mail export@galit.te.ua,

www.galit-dental.com

Introduction

When purchasing the dental unit, make sure that there is a stamp of the trading company, date of sale and signature of seller in section 9 of this manual for operation and in the coupons for warranty repairs. Check the completeness of the unit according to section 2.4 of this Operating Manual.

REMEMBER! In the absence of appropriate markings, the warranty period starts from the date of manufacture of the dental unit.

These operating instructions are an integral part of your new dental unit. Always keep it close to the unit so you or your technician can access it quickly and easily.

Read this operating manual and make sure you understand it completely before you start working with the dental unit. This operating manual cannot cover all aspects of use, but it can help to avoid mistakes when using your dental unit.

The information contained in this operating manual is correct and current at the time of printing. The information in the operating instructions is provided to facilitate the operation of the dental unit. Always follow the recommendations, they will help make the operation of your dental unit economical and efficient. Our units are constantly improved, their characteristics are improved, the design is updated, therefore the drawings and designations in this operating manual may slightly differ from your unit.



Translation of the instructions was made with appropriate competence and in good faith. However, we cannot take responsibility for translation errors. In case of inaccuracies in the translation, the Ukrainian version of the installation instructions and operating instructions is considered the main one.

If there are any damages or problems when using the dental unit, contact the service department of the company that sold you the unit.

If repairs are necessary, use only original spare parts to ensure that your dental unit works efficiently throughout its lifetime.

All products are tested and guaranteed for 12 months from the date of sale. This guarantee is provided to all customers who have fulfilled contractual and administrative obligations, installed and use the dental unit in accordance with the operating instructions. Under this warranty, the MANUFACTURER will repair or replace free of charge all components that are found to be defective due to the manufacturer's fault or fail during the warranty period.

The MANUFACTURER's technical assistance service is the only authority to determine whether a malfunction is covered by the warranty. The guarantee does not cover the labour costs of the employees of the Technical Assistance Service, which must be reimbursed. The warranty does not take into account the MANUFACTURER's liability for direct or indirect loss or damage caused to people or objects as a result of improper use or maintenance of the dental unit, while the warranty covers only materials and installation. Furthermore, the warranty does not cover the costs incurred by the MANUFACTURER's personnel for transportation, inspection, replacement or re-installation, unless the malfunctions are the result of defects in materials or assembly. All costs will be deducted from the user.

Equipment classification	
	<p>The following classification methods comply with IEC/EN 60601-1:</p> <ul style="list-style-type: none"> • According to the directive on medical devices 93/42/EEC, the dental unit corresponds to class II a. • In accordance with the requirements of IEC/EN 60601-1, the dental unit is class I equipment. • According to CISPR 11, the dental unit is ISM group 1, class B equipment.
 Marking UA.TR.099	National mark of compliance with technical regulations with the identification number of the designated conformity assessment body.
Marking CE	
	<p>This product meets the regulatory requirements of the European Union Directive 93/42/EEC on medical devices.</p> <p>Compliance with this Directive is evidenced by the CE sticker on the product.</p> <p>The location of the CE sticker is indicated in section 1.1 of the operating instructions.</p>



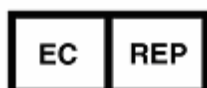
The dental device does not belong to measuring equipment for medical purposes and does not require periodic metrological attestation.

Відповідність міжнародним стандартам / Compliance with the certificates		
Стандарт/Standard	Українська назва / Ukrainian name	English title
93/42/EEC	Директива 93/42/ЄЕС від 14.06.1993 Щодо питання медичного обладнання	COUNCIL DIRECTIVE 93/42/EEC of 14 June 1993 concerning medical devices
EN 60601-1	Вироби медичні електричні. Частина 1. Загальні вимоги щодо безпеки та основних технічних характеристик	Medical electrical equipment. General requirements for basic safety and essential performance
EN 60601 -1-2	Вироби медичні електричні. Частина 1-2. Загальні вимоги щодо безпеки та основних робочих характеристик. Додатковий стандарт. Електромагнітна сумісність. Вимоги та випробування	Medical Electrical Equipment – Part 1-2: General Requirements for Basic Safety and Essential Performance – Collateral Standard: Electromagnetic Disturbances – Requirements and Test.
IEC 80601-2-60	Обладнання медичне електричне. Частина 2-60.	Medical electrical equipment - Part 2-60: Particular requirements for basic safety and essential performance of dental equipment
EN ISO 7494-1	Стоматологія. Установки стоматологічні. Частина 1. Загальні вимоги та методи випробування	Dentistry - Dental units - Part 1: General requirements and test methods
EN ISO 7494-2	Стоматологія. Установки стоматологічні. Частина 2. Водопостачання та подавання повітря	Dentistry - Dental units - Part 2: Air, water, suction and wastewater systems
ISO 10993-1	Біологічне оцінювання медичних виробів. Частина 1. Оцінювання та тестування в рамках процесу управління ризиками.	Biological evaluation of medical devices - Part 1: Evaluation and testing within a risk management process

European representative office

The European representative office is registered at:

Company Name: **Galdent CZ s.r.o.**
 Address: K.Vapence 448, 41503 Teplice, Czech Republic
 Company number: 103510996
 Easy number: 00007069449932
 National identification number: 28741536
 Registration number: C 29946



Certificates

No.: CE 703906

Service representatives in Europe (phone numbers, address):

1. Symbols

The following symbols are used in this operating manual:



ATTENTION!

Pay special attention to items marked with this sign.

These paragraphs describe actions that, if not followed, could result in personal injury or danger to life, or damage to the equipment, if this operating manual is not followed.



Caution, risk of electric shock.



REFER TO APPROPRIATE OPERATING INSTRUCTIONS OR GUIDELINES

(Instructions for use, operating manuals, accompanying documents).



BE SURE TO REFER TO THE INSTRUCTIONS OR OPERATING INSTRUCTIONS FOR THIS PRODUCT BEFORE USING THE PRODUCT

(Instructions for use, operating manuals, accompanying documents).



WORK ONLY WITH PROTECTIVE GROUNDING.



Operating part of type B *.

* type of user part of dental instruments (B or BF) see operating instructions for the instrument.

1.1 Identification Name Plate

An identification plate with the inscription of general data is placed on the adapter between the patient chair and the unit



Fig.1.1.1 Identification name plate for dental units with upper delivery of the instruments



Fig.1.1.2 Identification name plate for dental units with lower delivery of the instruments

Serial Number (SN): **XXXX MM YY** **XXXX** – dental unit №
MM – month of manufacture
YY – year of manufacture

When requesting information, services, or replacement parts, always include the model, type, and serial number of your dental unit. This information is indicated on the identification plate and in the warranty coupon for the dental unit.

Designations

	Manufacturer.
	This product meets the regulatory requirements of the European Union Directive 93/42/EEC on medical devices.
	ATTENTION! Pay special attention to items marked with this sign. These paragraphs describe actions that, if not followed, could result in personal injury or danger to life, or damage to the equipment, if this operating manual is not followed.
	Working part of type B*. Protection class I. <i>* type of user part of dental instruments (B or BF) see operating instructions for the instrument.</i>
	BE SURE TO REFER TO THE INSTRUCTIONS OR OPERATING MANUAL FOR THIS PRODUCT BEFORE USING THE PRODUCT <i>(Instructions for use, operating manuals, accompanying documents).</i>
	Manufacturing country. Year of manufacture.
	Disposal of electronic equipment in accordance with Directive 2002/96/EC.
	This product is a medical product.
	An authorized representative who distributes the medical product in the region.
REF	Number according to Catalogue

1.2 Content

Introduction.....	3
1. Symbols.....	5
1.1 Identification name plate.....	6
1.2 Content.....	7
1.3 Safety measures.....	8
2 Description of the dental unit.....	11
2.1 Product information.....	11
2.2 Designation of the component parts of the unit.....	12
2.3 Variants of versions of the doctor table.....	13
2.4 Technical Characteristics.....	14
2.5 Delivery set.....	15
3 Installation of external service lines.....	16
3.1 High-speed suction system.....	17
4 The unit switching on.....	18
4.1 Checking the unit before starting work.....	Помилка! Закладку не визначено.
5 Doctor Table.....	20
5.1 Doctor table control panel.....	20
5.1.1 Patient chair control panel.....	21
5.2 Adjustment of operating modes of instruments on the doctor table.....	22
5.2.0 Fixing position of the doctor table.....	23
5.2.1 Dental syringe.....	24
5.2.1.1 dental syringe LUZZANI.....	24
5.2.1.2 3-way dental syringe DCI.....	25
5.2.2 Pneumatic turbine.....	26
5.2.3 Electric micromotor.....	28
5.2.3.1 Electric micromotor BIEN AIR.....	28
5.2.3.2 Electric micromotor NSK.....	29
5.2.4 Piezoelectric scaler.....	30
5.2.5 Curing lamp.....	34
5.2.6 Coagulator.....	35
5.3 Option of version of dental unit "GALLANT DU/DL" with ENDO option.....	36
5.3.1 Adjusting the frequency of rotation of the micromotor at II - IV workplace in normal mode.....	38
5.3.2 Adjusting the rotation frequency of the micromotor in ENDO mode.....	40
5.3.3 Adjusting the torque of the micromotor at III workplace in ENDO mode.....	42
6 Assistant table.....	43
6.1 Assistant table control panel.....	43
6.2 Adjusting working modes of tools on the assistant unit.....	44
6.3 Programming working positions of the dental chair.....	44
7 Water Unit.....	45
7.1 Functions of the cup filling cuspidor bowl rinsing.....	45
7.2 Programming the time of cup filling and cuspidor bowl rinsing.....	46
7.3 Memorization of "spray" and "illumination" modes for I-IV instruments.....	48
7.4 Distilled Water System.....	49
8 Maintenance.....	50
8.1 Recommended products for care, cleaning and disinfection.....	50
8.2 Care of instruments.....	53
8.3 Lamp (dental).....	54
8.3.1 Lamp (dental) MAIA.....	54
8.3.2 Lamp (dental) ALYA.....	55
8.3.3 Lamp (dental) EVA.....	56
8.4 Cleaning the cuspidor filter.....	57
8.5 Cleaning the exhaust air filter of pneumatic outlets.....	57
8.6 Draining condensate from the dental unit.....	58
8.7 Cleaning the exhaust air filter of pneumatic outlets.....	59
8.8 Coarse cleaning filter.....	59
8.8.1 Maintenance of the aspiration system.....	60
8.8.2 Cleaning the filter of the aspiration unit.....	62
8.9 Separator.....	63
8.9.1 Separator "CS1".....	63
8.9.2 Maintenance of the separator CS1 of the aspiration system with a collector of solid particles.....	64
8.9.3 Separator of "Cattani" company.....	65

8.9.4 Separator “CAS1”	66
8.10 Replacement of fuse links	68
8.11 Recommended maintenance frequency	71
8.12 Technical malfunctions and methods of their elimination	71
8.13 Disinfection. Flushing the internal channels of the hoses of the dental unit.....	72
9 Electromagnetic compatibility (EMC) (MEK 60601-1-2).....	74
10 Disposal.....	78
Appendix A1. Overall dimensions of “Gallant DU” dental unit.....	79
Appendix A2. Overall dimensions of “Галлант DL” dental unit.....	80
Appendix Б. Recommended plan for supply of service lines for dental unit “GALLANT DU/DL”.....	81
Appendix B. Checking parameters of dental equipment	83
Appendix Г. Dental unit “GALLANT OMNIPRATIQUE”. Pneumatic diagram (with additional options).....	85
11. Warranty General Conditions	87

1.3 Safety Measures

In terms of safety, the product meets the requirements of IEC/EN 60601-1 and is Class I Type B* equipment.

* type of user part of dental instruments (B or BF) see operating instructions for the tool.

- Installation of the unit must be performed by personnel who have the right to do so and in accordance with the "Installation Instructions".

- The unit must be connected to a network with protective earthing.

- Operation of dental equipment (dental chair, lamp, dental unit) without reliable grounding is strictly prohibited.

- It is strictly forbidden to carry out troubleshooting in the unit connected to the power mains.

- It is prohibited to use the device to persons who have not read this operating manual in detail.

- Follow the instruction manual for proper use.

- Do not use the device if there are signs of damage. In case of malfunctions, call an authorized technician.

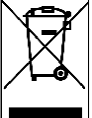
- Replace damaged parts and components only with original spare parts approved for replacement by the company GALIT.

- Always turn off the main power switch of the unit after finishing work.



General safety instructions

Intended use	<p>This dental unit is used for therapy, diagnosis and treatment of teeth by trained personnel.</p> <p>This product is not intended for use in explosive atmospheres.</p>
Installation performed by the user on site	<p>Installation of the unit must be performed according to the requirements of the manufacturer. A detailed description is presented in the installation instructions.</p>
Care and repair	<p>As a manufacturer of dental equipment, in order to ensure the operational reliability and safety of the product, we attach great importance to the fact that maintenance and repairs are performed only by us or by personnel who have received from us the exclusive right to do so, and in the event of failure of parts that affect the safety of work product, they were replaced only with original spare parts.</p> <p>When carrying out such work, it is recommended to obtain a document from the manufacturer indicating the type and scope of work, if necessary, with information about changing the nominal parameters or working range, and with the date, information about the manufacturer, and a signature.</p>
Changes to the product	<p>Changes to the product that may affect the safety of the user, patient or other persons are strictly prohibited in accordance with the law!</p> <p>To ensure operational reliability and safety, this product may be operated only with original components manufactured by Galit or with components from other manufacturers authorized by Galit. The user bears all responsibility for the use of unauthorized components (parts).</p> <p>All products connected to the dental unit must comply with the current regulations:</p> <p>IEC 60950 for data processing and transmission systems (for example, PCs), as well as IEC 60601-1 for medical and technical equipment.</p>
Combination with other devices	<p>When connecting the device to other equipment (for example, a PC), as well as changing the electrical system, the user is responsible for ensuring that the requirements of the IEC 60601-1-1 standard (Regulations for the safe operation of medical electrical systems) related to patient safety are fully met, service personnel and the environment.</p> <p>If in doubt, consult the manufacturer of the dental device.</p>
Electromagnetic compatibility (EMC)	<p>The dental unit "GALLANT DU/DL" meets the requirements of the IEC 60601-1-2 standard.</p> <p>The dental unit "GALLANT DU/DL" meets the requirements of electromagnetic compatibility group 1 class B according to ΔCTY CISPR 11.</p> <ul style="list-style-type: none">• Group 1 – medical equipment in which radio frequency energy is intentionally generated or used with a conductive connection necessary for the internal functioning of the equipment itself.• Class B equipment is equipment suitable for domestic use and installations that are directly connected to the low-voltage power supply network that supplies buildings used for domestic purposes. <p>Class B equipment must comply with Class B standards.</p>

Electromagnetic compatibility (EMC)	<p>Medical electrical equipment must meet all safety requirements for EMC.</p> <p>The equipment must be installed and operated in accordance with the instructions given in the document "Electromagnetic compatibility (EMC) (MEK 60601-1-2)".</p> <p>Portable and mobile RF communication devices can affect electro-medical equipment. It is necessary to prohibit the use of radio telephones on the territory of clinics and medical practices.</p>
Quality of water/air supplied	<p>Air and water supply must meet the requirements specified in the instructions. Use only clean water.</p>
Requirements for water characteristics	<p>User of the dental unit is responsible for the quality of the water supplied and, if necessary, must take alternative measures to comply with water requirements.</p>
Suction system	<p>Suction of aluminium oxides or other metals from the jet devices through the separation automation and amalgam separator built into the dental unit is prohibited! This leads to extreme wear and clogging of suction and drainage channels.</p> <p>When using metal-oxide jet devices, a separate suction device must be used.</p> <p>Dental units with central wet suction are fundamentally suitable for suction of the above-mentioned materials. Strictly follow the instructions of the manufacturer of your suction system.</p> <p>There are still no restrictions for the use of jet devices in combination with "GALLANT OMNIPRATIQUE" dental devices. But at the end of the work, it is necessary to ensure sufficient washing with water.</p>
Dental chair	<p>Consider the maximum load on the dental chair, which is equal to 135 kg according to EN ISO 6875 (tested with a four-fold safety margin).</p>
Maintenance of the dental unit	<p>In order to ensure the normal functioning of the unit, it is necessary to carry out regular maintenance and preventive work at the established frequency to ensure operational reliability and safety of work.</p> <p>In order to ensure the operational safety and suitability of the dental unit, to prevent damage caused by natural wear and tear, it is necessary to regularly inspect the unit by employees of the technical support company. In addition, safety control must be performed.</p> <p>Please contact the manufacturer's service center for a maintenance quote.</p>
Disassembly and reassembly	<p>When disassembling and reassembling the product, you must follow the instructions given in the installation instructions to ensure the operability and stability of the product.</p>
Disposal 	<p>According to directive 2002/96/EC, to prevent environmental pollution and injury during disposal, please follow the disposal laws.</p> <p>Disposal recommendations are described in section 10.</p>

2 Description of the dental unit

Dental unit "GALLANT DU/DL" is a complex medical product, which consists of the following main elements: patient chair, doctor table, assistant table, water unit, operating lamp, foot control. For operation of the dental unit, it is necessary to have: compressed air, suction system, water supply and sewage system.

"GALLANT DU/DL" units are designed for use with patient chair **ECO NEXT, STING** (TECNODENT, Italy).

Standard version of the dental unit includes:

- doctor table on a rotary lever with possibility of installing 5 different instruments;
- water unit with a cuspidor unit. This includes a distilled water system, a water ejector saliva ejector on a rotary lever;
- shadowless lamp on the pantographic console.

Functionally, the following operations can be performed on the "Gallant DU/DL" dental unit:

- adjustment of the rotation frequency of the micromotor from 3700 to 42,000 rpm. in normal mode and from 550 rpm to 2900 rpm. in ENDO mode;
- creation of rotating motion of a pneumatic turbine with a rotation frequency of up to 310,000 rpm;
- supply of liquid from the "distilled water" system to the multifunctional dental syringe;
- cup filling;
- cuspidor bowl rinsing;
- control of the saliva ejector;
- turning on and off the lamp;
- adjustment of scaler power at vibration frequency in the range (22-30) kHz.

Functional capabilities of dental units are set separately for each product depending on the order, including additional needs of a specific consumer.

However, there is a minimum list of functions that any dental unit must perform.

Upon request, the Manufacturer will provide the necessary wiring diagrams, component specifications, setup instructions, and other information necessary for Service Personnel to replace those parts identified by the Manufacturer as Serviceable.

2.1 Product information

Intended Use

Dental unit "Gallant DU/DL" (hereinafter referred to as the unit) is intended for provision of dental care in polyclinics, hospitals and other medical facilities.

Area of use of the units is medical and orthopedic stomatology.

Installation in medical facilities: During development and manufacture of the dental unit, all special requirements for medical products were taken into account. When installing equipment in medical facilities during mechanical and electrical installation, it is necessary to comply with the requirements of the **EEC directive 93/42 on medical devices, standards IEC 60601-1, IEC 60601-1-1, IEC 60601-1-2.**

Inappropriate use

Any other use of the product, not provided for in this manual, is considered improper use. The manufacturer is not responsible for any damage caused as a result. All risks in this case are borne by the user.

2.2 Designation of component parts of the unit



Position	Name
1	Water Unit
2	Dental Chair
3	Dental unit control pedal
4	Dental pedal
5	Assistant table
6	Doctor table
7	Doctor table rotary arm
8	Doctor table arm
9	Dental lamp
10	Dental lamp arm
11	Dental lamp rotary arm

Figure 2.2.1 Dental unit "GALLANT DU" with patient chair STING.

2.3 Variants of versions of Doctor Table

Doctor table on rotary lever with upper (Figure 2.3.1.) or lower (Figure 2.3.2.) placement of hoses includes the following components:

- 3-way syringe;
- turbine pneumatic outlet with lighting;
- electric micromotor MC2 (Bien Air, Switzerland);
- negatoscope;
- control panel to control dental unit and chair.



“GALLANT-U”
with upper placement of instrument hoses
(Figure 2.3.1);





“GALLANT-L”
with lower placement of instrument hoses
(Figure 2.3.2);

2.4 Technical Characteristics

Supply voltage	220 V, 50 Hz
Water supply network pressure	3-4 kg/cm ²
Water consumption	Up to 10 l/min*
Compressed air network pressure	5,5-8 kg/cm ²
Compressed air consumption	30-70 l/min*
Maximum current consumption	5A
Average power consumption:	
doctor table	140 VA
water unit	135 VA
chair	850 VA
lamp	90 VA
in standby mode	20 VA
in operating mode	200 VA
Maximum power consumption	1100 VA
Maximum load on the table for instruments	2kg
Weight	130-160 kg*

***Note:** depending on the configuration of the dental unit.

Conditions of transportation and storage	Ambient temperature:	-40°C – +70°C
	Relative humidity of air:	10% – 100%
	Atmospheric pressure:	500 – 1060 hPa
Terms of use	Ambient temperature:	+10°C – + 40°C
	Relative humidity of air:	30% – 75%
	Atmospheric pressure:	700–1060 hPa
Class of protection	Protection class I product	
Degree of protection against electric shock:	Type B user part	
Degree of protection against water ingress according to IEC 60529 (dental unit)	IPX0 Normal product (no protection)	
Degree of protection against water ingress according to IEC 60529 (pedal)	IPX1	
Mode of operation	Continuous mode with repeated short-term load according to the work of the dentist.	
	Stationary installed product.	
Year of manufacture	 (on the identification plate of the unit)	20XX

2.5 Set of Delivery

1	Dental Unit "GALLANT DU/DL"	SN:	1 pc.	<input type="checkbox"/>
2	Operating Manual to dental unit "GALLANT DU/DL"		1 pc.	<input type="checkbox"/>
3	Installation Manual to dental unit "GALLANT DU/DL"		1 pc.	<input type="checkbox"/>
4	A set of mounting parts (located in the box of mounting and spare parts)		1 pc.	<input type="checkbox"/>
5	Patient chair		1 pc.	<input type="checkbox"/>
6	Operating Manual to Patient Chair		1 pc.	<input type="checkbox"/>
7	Lamp EDI/MAIA/ALYA/EVA		1 pc.	<input type="checkbox"/>
8	Operating Manual to Lamp		1 pc.	<input type="checkbox"/>
9	Foot Control		1 pc.	<input type="checkbox"/>
10	Accessories that are part of the unit with relevant operating manuals. <i>Specify the model</i>	SN:		
	1) micromotor		1 pc.	<input type="checkbox"/>
	2) micromotor		1 pc.	<input type="checkbox"/>
	3) micromotor		1 pc.	<input type="checkbox"/>
	4) syringe		1 pc.	<input type="checkbox"/>
	5) curing lamp		1 pc.	<input type="checkbox"/>
	6) scaler		1 pc.	<input type="checkbox"/>
	7) separator		1 pc.	<input type="checkbox"/>
	8) water unit heater		1 pc.	<input type="checkbox"/>
	9) doctor table heater		1 pc.	<input type="checkbox"/>
	10) monitor		1 pc.	<input type="checkbox"/>
	11) camera		1 pc.	<input type="checkbox"/>
	12) cuspidor valve		1 pc.	<input type="checkbox"/>
	13)			<input type="checkbox"/>
	14)			<input type="checkbox"/>
	15)			
	16)			
	17)			
11	Set of certificates and licences		1 pc.	<input type="checkbox"/>

3 Installation of external service lines



The manufacturer is not responsible for damage or non-compliance with the technical characteristics of the equipment in case of non-compliance with the following requirements for external service lines

Requirements for external service lines

Water supply network:

- Water quality – drinking water.
- Water hardness - 1.5 - 2.14 mmol/l = 8.4 - 12 dH.
- pH level is from 7.2 to 7.8.
- The water should be of medium / low salt content (if necessary, install a water softener). The pressure in the water supply network should be within 3÷4 bar. If the water pressure in the water supply network exceeds 6÷8Bar, an additional reducer must be installed.
- Water filtration provided by the party performing construction (installation) work - 80 microns.
- To prevent water from the unit from entering the water supply network, the unit must have a return valve.
- The water supply network at the point of connection to the installation must end with a 1/2" threaded connection or a fitting designed to connect a \varnothing 6x8 mm water supply hose to the unit. Before connecting the water, drain the rusty water from the water supply network.
- Connect the water supply system to the unit: Connect the water supply hose to the unit ("H2O" marking) to the water supply network using a 1/2" external adapter on a hose \varnothing 6x8 mm from a set of mounting parts. Cut off the rest of the hose.

Compressed air:

- **Compressed air without oil additives** and preferably dried. Dried air extends the service life of pneumatic tools.
- Minimum pressure 5.5 bar; The maximum pressure is 8 bar. The compressed air hose at the point of connection to the unit must end with a 1/2" internal thread or a fitting designed for connecting a \varnothing 6x8 mm hose.
- Air filtration provided by the customer - 50 microns.
- Lower suction pressure – static at the entrance to the device: max. 180 mbar, dynamic: > 45 mbar, recommended: 60 mbar.
- Approximate productivity of suction is 500 standard l/min.
- Connect the compressed air system to the unit: Connect the **compressed air** supply hose to the unit (labeled "AIR") to the compressed air system (compressor), if necessary, using a 1/2" external adapter on a hose \varnothing 6x8 mm from a set of mounting parts. Cut off the remainder of the hose.

Drain:

- A pipe with an internal \varnothing of 50 (or 40) mm with an inclination of 8 degrees.
- The recommended height of the end of the pipe above the floor level is no more than 50 mm.
- Sewage connection to the UNIT: Connect the **drain** hose from the unit (internal \varnothing 16 mm) to the sewer of the dental office, if necessary, using a rubber adapter from \varnothing 20 mm to 50 mm and a plastic elbow from the set of mounting parts. Cut off the remainder of the hose.

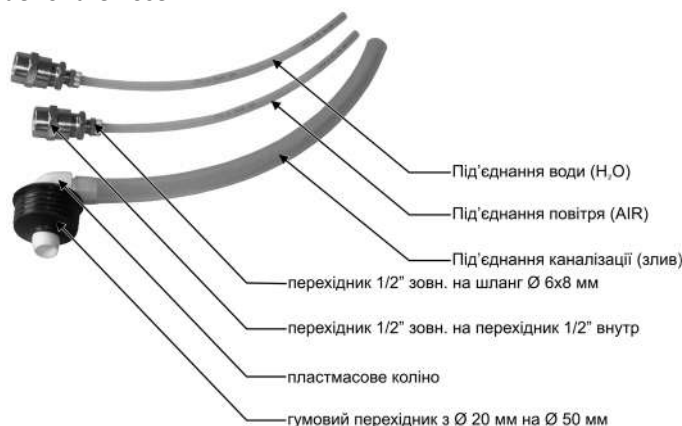


Figure 3.1

- **When using plastic pipes for the supply of service lines, use only polypropylene pipes of the HT brand, DIN V 19560 (with red marking) with 2-cuff seals or similar pipes.**
- **Do not use stabilized HT pipes, DIN 19561 (with yellow marking, easily engaged) for the supply of service lines. They are made of ABS plastic / or ASA and are not resistant to medicines and solutions used in dentistry.**



3.1 High-speed suction system

High-speed suction system (for versions of dental units with high-speed suction)

- connect the corrugated hose (internal \varnothing 30 mm) with the hose of the suction aggregate, if necessary, use the rubber adapter \varnothing 50 mm - \varnothing 30 mm from the assembly parts kit;
- connect the high-speed suction aggregate to the installation;
- connect the control wires of the suction aggregate to connector MS3 or MS4 on the water unit controller board of the unit according to Figure 3.1.1.



When connecting the dental unit "GALLANT DU/DL" to the suction aggregate, which is already in operation, it is necessary to select the necessary method of controlling the aggregate (~24V or short-circuit) and the same method as in other parallel connected dental units. Failure to comply with this requirement leads to the burning of the fuse link F4 on the water unit controller board.

To connect the high-speed suction aggregate to the dental unit it is necessary:

- turn off and disconnect the unit from the electrical network;
- if the suction aggregate is turned on by supplying an alternating voltage of ~24V, then connect the control cable of the suction aggregate to MS3 connector on the water unit controller board; MS3 connector is labelled "AGR AC 24V";
- if the suction aggregate is turned on by short-circuiting the contacts of the aggregate itself, then connect the control cable of the aggregate to MS4 connector on the water unit controller board; MS4 connector is labelled "AGR short circuit";
- put the water unit cover in place.

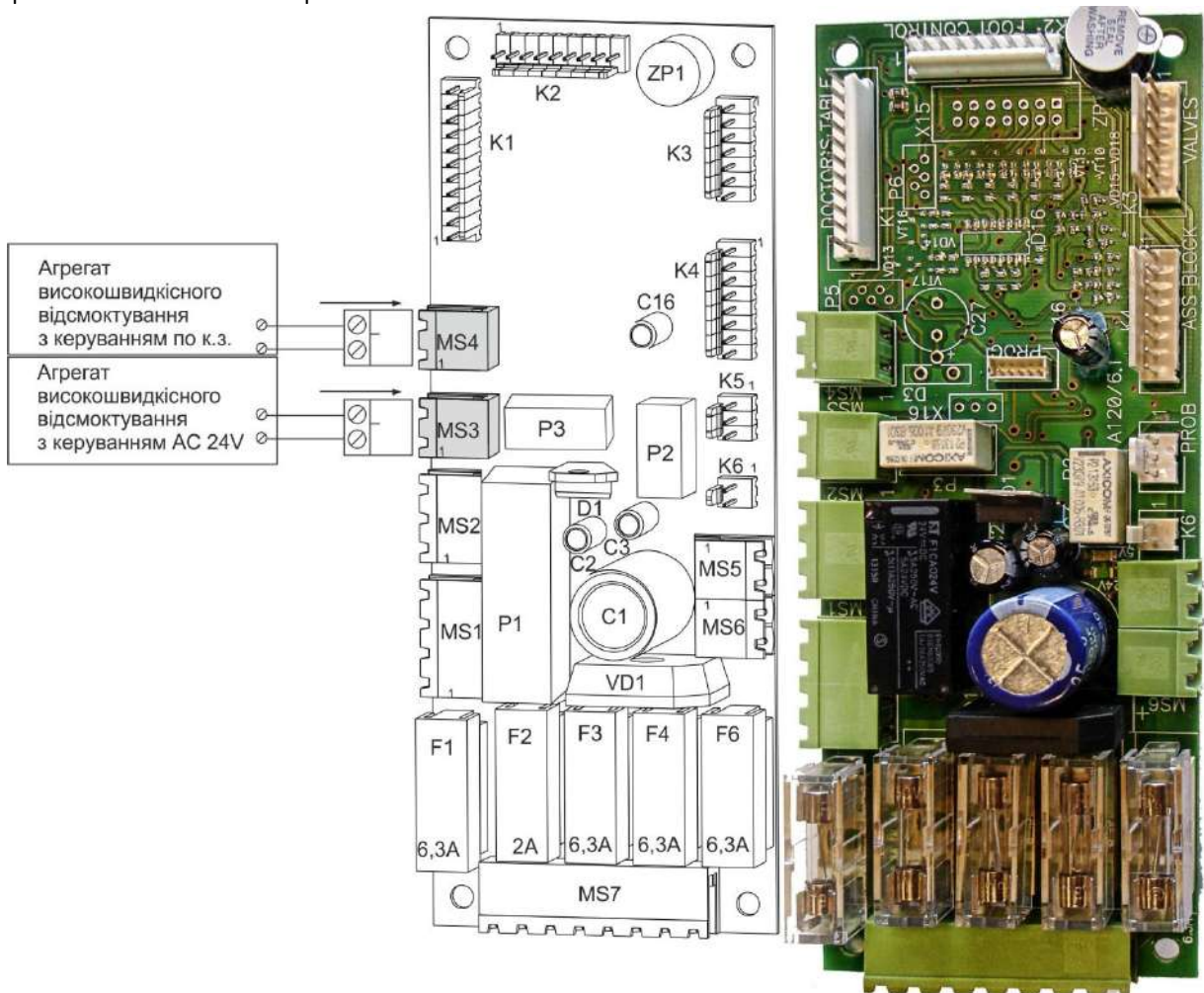


Figure 3.1.1

4 Unit switching on

1. Connect the plug of the power cable of the unit to a power outlet (~220 V, 50 Hz) with a grounding contact.
2. Turn on the main switch of the unit. The light indicator of this switch indicates that the power is on.
3. Open the compressed air and water supply taps to the unit.

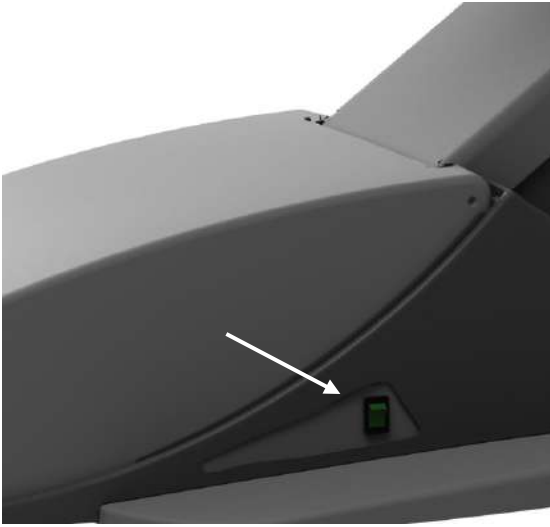


Figure 4.1.a- chair ECO NEXT



Figure 4.1.6- chair 2009 NEXT



Figure 4.1.b- chair ECO 19




Figure 4.1.r- chair STING

4.1 Checking the unit before starting work

1. Check operation of the lamp.

2. Check operation of filling the cup and rinsing the bowl:

- when you briefly press the **cup filling button**  on the doctor table control panel (Figure 5.1.1) or on the assistant table control panel (for versions with the assistant table control panel) - water enters the cup within 3 seconds. If you press the control panel button again before 3 sec., supply of water to the glass stops;

- by briefly pressing the **bowl rinsing button**  on the doctor table control panel (Figure 5.1.1) or on the assistant table control panel (for versions with assistant tables) – the bowl rinsing is taking place within (10-12) sec. If you press the control panel button again earlier than (10-12) sec., the bowl rinsing stops.

3. Check operation of the saliva ejector: the saliva ejector starts working after removing it from the holder.

4. Check operation of the instruments of the doctor table (see section 5 of the Instructions): for pneumatic instruments and instruments with cooling, adjust additional working pressures and flows of water-air cooling mixtures.

5. Check operation of the high-speed suction system (for versions with a high-speed suction system): the suction aggregate must start after removing the suction hose from the holder and stop after inserting the hose into the holder of the assistant table control panel.

5.1.1 Patient Chair control panel



or



Moving the seat up.



or



Moving the backrest up.



Moving the patient chair up / down.



Raising / lowering the backrest of the patient chair.



When pressed for a short time, the chair is set to the "0" position.

When pressed for a long time - moving the seat down.



With a short press - raising the back of the patient chair to the patient sitting position for rinsing the mouth.

Figure 5.1.1.1

5.2 Adjustment of operating modes of instruments on doctor table



In section 5.2. "Adjusting the working modes of instruments on the doctor table" describes only the general rules for using working instruments and the general rules for adjusting these instruments. Detailed instructions for the operation and maintenance of work instruments, as well as the delivery set, are specified in the operating documentation for these instruments.

Instruments, except for the dental syringe and some models of curing lamps, are controlled by a pneumatic pedal through a microcontroller board, which is located in the doctor table.

The microcontroller controls the turning on / off of the instruments, the rotary movement of the micromotor in normal mode and ENDO mode, supply of spray and illumination, operation of the diathermocoagulator and scaler, if there are any in the doctor table.

The internal software of the microcontroller is oriented to any customer with an arbitrary set of instruments and their placement on the doctor table. In particular, micromotors can be placed on the second, third or fourth working place with the maximum permissible supply voltage from the range of 24V, 30V. It is also possible to place scalers from different manufacturers with different requirements for output power regulation, etc.

Correspondence between internal software of the microcontroller and the set of instruments and their placement is established when ordering a dental unit and is performed only at the Galit enterprise.

All operational final settings of the power level, rotation frequency, and indications performed by the doctor during work are stored in the microcontroller's memory. When the power is turned on again, all the last settings are saved.

System of priority selection of instruments prevents simultaneous operation of several instruments. Control is carried out by the first removed instrument.

The pneumatic pedal makes it possible to start pneumatic instruments and adjust their speed.



ATTENTION! Before removing the instrument from the doctor table, make sure that the instrument control pedal is not depressed. Otherwise, the tool will start working automatically and may cause personal injury.

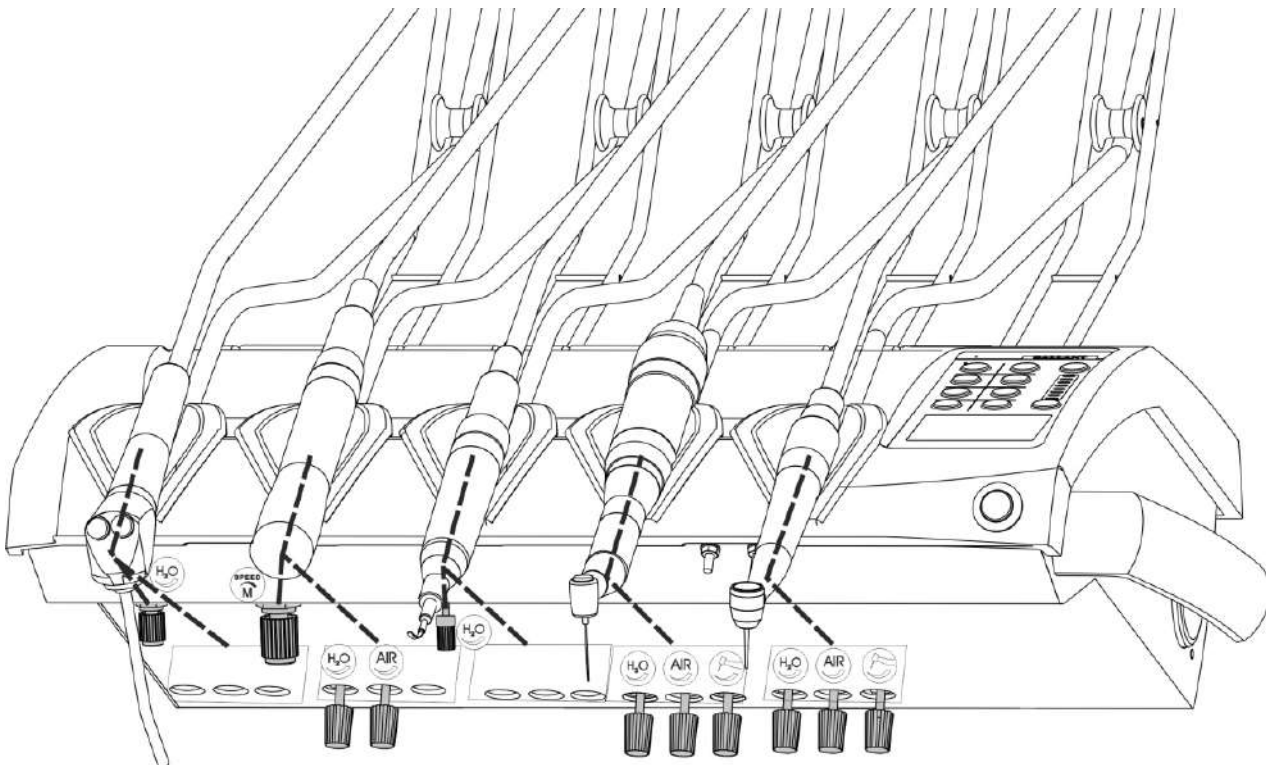












Fig. 5.2.1 Placement of regulators of working instruments on the doctor table with the upper delivery of hoses.

Adjustment of the working modes of the instruments is carried out with the help of adjustment controls, which are located under the doctor table (below). Each instrument has its own adjustment block, which is located under the corresponding instrument. Operational adjustments are on the same axis as the instrument.

Table 5.2.1 shows options for adjustment blocks of working instruments.

Table 5.2.1

Marking	Block of adjustment of pneumatic outlet №1	Block of adjustment of pneumatic outlet №2	Block of adjustment of electric micromotor	Block of adjustment of scaler	Block of adjustment of 3-way syringe
					
	operating pressure (2,5 ± 0,3 bar) *	operating pressure (2,5 ± 0,3 bar) *	X	X	X
	air flow in the water-air cooling mixture	air flow in the water-air cooling mixture	air flow in the water-air cooling mixture	X	X
	water flow in the water-air cooling mixture	water flow in the water-air cooling mixture	water flow in the water-air cooling mixture	water flow	water flow
	X	X	Revolutions of the electric micromotor	Power of the scaler is regulated by buttons  on the doctor table	X
ENDO/ PERIO/ SCALING	X	X	X	operating mode switch	X

***Note** working pressure for the pneumatic turbine is set on the manometer according to the technical requirements for a specific model of the turbine.

5.2.0 Fixing position of the doctor table

To fix the doctor table, you need to press and hold the button (Figure 5.2.0), select an optimal position for work and release the button. The locking button is located on the front cover of the doctor table, it prevents accidental movement during operation.



Figure 5.2.0

5.2.1 Dental syringe

5.2.1.1 Dental syringe LUZZANI



Figure 5.2.1.1.1.

1. Procedure for the syringe operation:

- Take off the syringe from the instrument table;
- To get **water**, press the left button on the syringe body. To get **air**, press the right button on the syringe body. To obtain **water-air mixture (spray)**, press two buttons on the syringe body at the same time;
- To change the angle of the nose inclination, turn the nose of the syringe to the required position.

2. The mode of operation of the dental syringe is a repeatedly - short-term mode.

3. Syringe maintenance:

Clean the nose of the syringe with a mandrel.

Carry out **Disinfection** of the external surfaces, buttons, body, with a soft cloth moistened with a disinfectant solution.

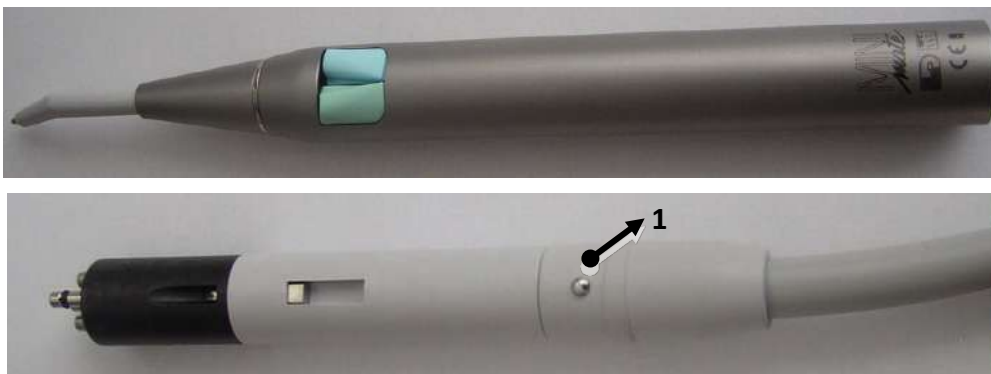


Figure 5.2.1.1.2.

Sterilization: press the button (position 1 Figure 5.2.1.1.2.), remove the tip with the body without disassembling the syringe nose, place in an autoclave at a temperature of +1350C, sterilize for 20 minutes.

Technical characteristics of the syringe:

Max. Water inlet pressure	Bar	2,5
Max. Air inlet pressure	Bar	4,5
Air flow rate	NI / min	10
Water flow rate	cm2 /min	110



Detailed instructions for the operation and maintenance of the dental syringe and the delivery set are provided in the operational documentation for the syringe.

5.2.1.2 3-Way Dental Syringe DCI

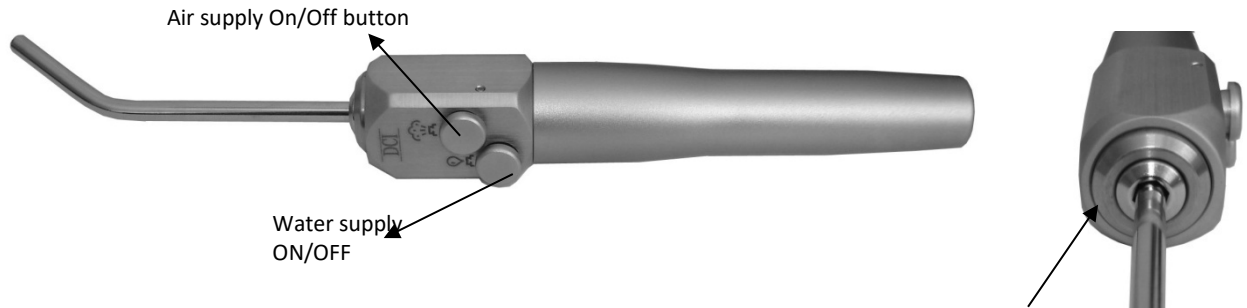



Figure 5.2.1.2.1

1. Procedure of the syringe operation:

- Take off the syringe from the instrument table;

- To get **water**, press the left button  on the syringe body.

To get **air**, press the right button  on the syringe body.

To get **water-air mixture (spray)**, press two buttons on the syringe body at the same time;

- To change the angle of the nose inclination, turn the nose of the syringe to the required position.

2. The mode of operation of the dental syringe is a repeatedly - short-term mode.

3. Syringe maintenance:

Clean the nose of the syringe with a mandrel.

Carry out **Disinfection** of the external surfaces, buttons, body, with a soft cloth moistened with a disinfectant solution.

Sterilization of the syringe nose should be carried out in an autoclave at a temperature of +135°C for 20 minutes. To remove and then install the nose in the syringe body, you need to press the ring according to figure 5.2.1.2.1.



Detailed instructions for the operation and maintenance of the dental syringe and the delivery set are provided in the operational documentation for the syringe.

5.2.2 Pneumatic Turbine

1. Connection of pneumatic outlet

The pneumatic outlet of the unit has a four-channel hose with a connection to a turbine, pneumatic motor or pneumatic scaler.

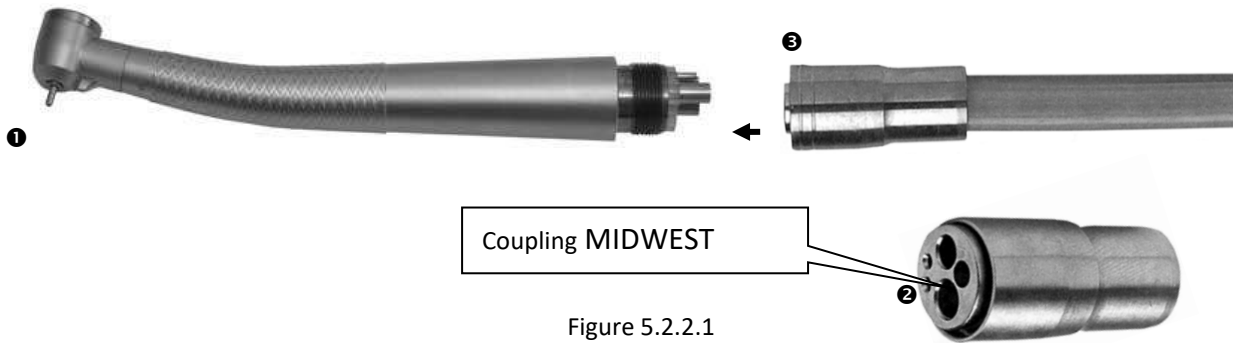


Figure 5.2.2.1

2. Preparation for work:


Connect turbine 1 to pneumatic outlet 2 and tighten nut 3.



CAUTION!

It is strictly forbidden to switch on the turbine without an instrument installed in the handpiece!

3. Procedure of the turbine operation:

- Take off the turbine from the doctor table and press the foot control;
- Set operating pressure by the control  located on bottom of the doctor table opposite the pneumatic outlet according to the doctor table pressure gauge index or with help of control pressure gauge REF 1600242-001 "Bien Air".




ATTENTION!

Operating pressure of the pneumatic outlet is set separately for each specific model of the pneumatic turbine according to its technical requirements.

- Set proportion of water-air mixture for cooling with controls  and  on bottom of the doctor table opposite the pneumatic outlet.

4. Procedure for adjusting pressure of the pneumatic turbine according to the control manometer.

- Take off the instrument;
- Connect the control manometer according Figure 5.2.2.2 or Figure 5.2.2.3;
- Press the pneumatic foot control to the stop, which corresponds to the maximum speed of rotation of the turbine **(for a pneumatic foot control)**;
- Set the foot control lever to the extreme right position, which corresponds to the maximum speed of the turbine **(for a multi-function foot control)**;
- Set needed pressure by control  on bottom of the doctor table opposite the pneumatic outlet.

5. Mode of Operation.

Turbine operation mode in accordance with the operational documentation.

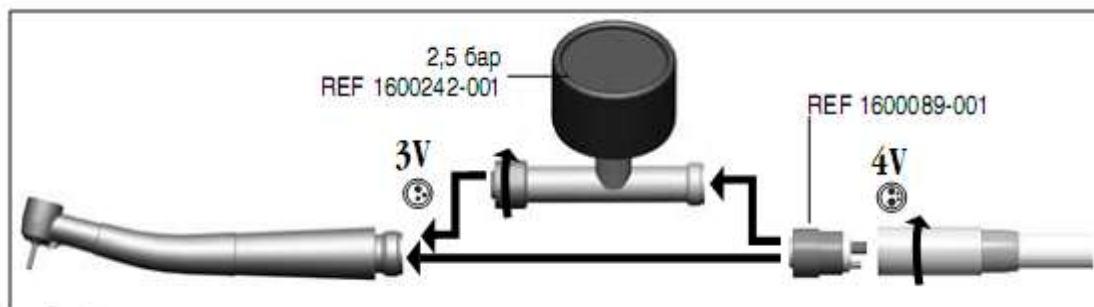


Рисунок 5.2.2.2

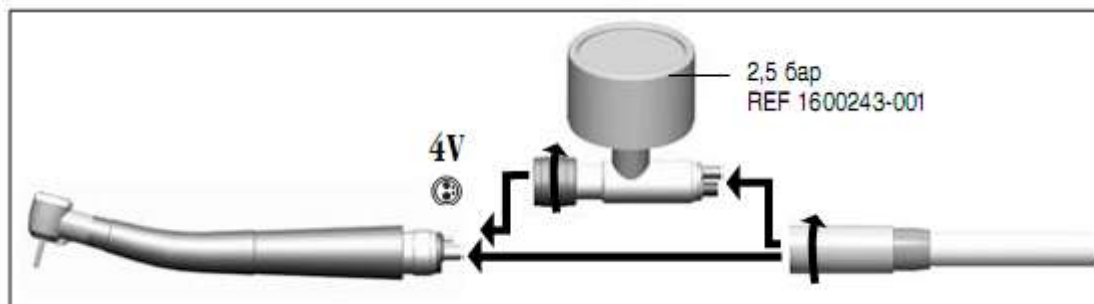


Figure 5.2.2.3

Figure 5.2.2.2. and Figure 5.2.2.3. — Connection diagrams of the control manometer.



ATTENTION! Periodically and after replacing pneumatic instruments, control the working pressure. Manometer on the doctor table is not a measuring device, it performs the functions of an indicator.

Note. The measurement error of the manometer of the doctor table due to the length of the hose does not exceed 0.3 bar.

6. Turbine maintenance:



WARNING! The durability of the turbine handpieces depends on the fulfilment of the lubrication requirements, as well as on compliance with the recommended operating pressure.

Detailed instructions for the operation and maintenance of the pneumatic turbine and the delivery set are given in the operational documentation for the turbine.

5.2.3 Electric Micromotor


5.2.3.1 Electric Micromotor BIEN AIR



ATTENTION! It is strictly prohibited to switch on the electric micromotor without an instrument installed in the handpiece!

1. To start the micromotor, take off the instrument from the holder and press the foot control. The micromotor will rotate clockwise.

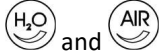
Speed of rotation of the micromotor is set by the speed control  of block of adjustment of electric micromotor (Table 5.2.1.) or the slider of the multi-functional foot control.

2. To reverse direction of rotation, release the foot control and then press the reverse activation button  on the doctor table control panel.



ATTENTION! Direction of rotation is changed only when the instrument comes to a complete stop

3. In micromotors with water-air mixture supply for cooling, proportion of water-air mixture is set by controls



of the electrical micromotor adjustment block.

For micromotors with light, switch on the light by means of the button for switching on the light of the instruments



on the doctor table control panel.

To ensure reliable operation of the micromotor, use only dry compressed air.

4. Cooling of the micromotor.

Cooling of the micromotor is set at the manufacturer enterprise. When replacing the micromotor, the cooling is adjusted and checked. The check is carried out using an air flow meter (flow meter for motor, N107.24.08, order code 1600307-001, "Bien Air", Switzerland)




Detailed instructions for the operation and maintenance of the electric micromotor and the delivery set are given in the operational documentation for the micromotor.


Micromotors of company **BIEN AIR**, models **MC2** and **MC3** have ENDO function.

5.2.3.2 Electric Micromotor NSK





ATTENTION! It is strictly forbidden to switch on the electric micromotor without an instrument installed in the handpiece!


1 To start the micromotor, remove the instrument from the holder and press the foot control. The micromotor will rotate clockwise. The speed of rotation of the micromotor is set by the speed regulator  of the electrical motor adjustment block (Table 5.2.1.) or by the multifunctional foot control slider.

2 To change the direction of rotation, release the pedal and then press the reverse button  on the doctor table control panel.



ATTENTION! Direction of rotation is changed only when the instrument comes to a complete stop.

3 In micromotors with water-air mixture supply for cooling, the proportion of water-air mixture is set by regulators  and  of the electrical micromotor adjustment block.

For micromotors with lighting - switch on the light with the button for switching on the light of the instruments  on the doctor table control panel.

To ensure reliable operation of the micromotor, use only dry compressed air.

4 **Cleaning**

Manual: Rinse the external surface of the micromotor in running water (<38°C, demineralized water is recommended).

Disinfection

Manual: Wipe the outer surface of the micromotor with a cleaning or disinfecting solution.

Lubrication

NSK surgical micromotors are maintenance-free. Do not lubricate the micromotors.

Sterilization

The micromotor can be repeatedly sterilized in an autoclave at a maximum temperature of 135°C (together with the cap for autoclaving and the cover of the micromotor).

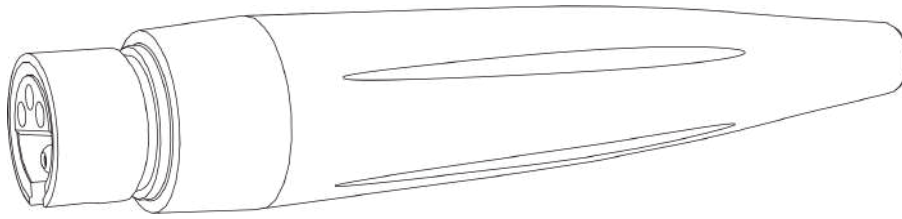
Table 5.2.3.2.1 Technical Specifications.

Motor type	NLX nano	NLX plus	M40XS
Maximum power	19V/5A	25V/5A	24V/5A
Speed	1.000-40.000 rpm/min	100-40.000 rpm/min	60-40.000 rpm/min
Torque	max. 3,4 N·cm	max. 4,0 N·cm	max. 3,4 N·cm
Overall dimensions	70mm x 22mm	77mm x 22mm	91mm x 21mm
Water spray	>65 ml/min	>65 ml/min	>65 ml/min



Detailed instructions for the operation and maintenance of the electric micromotor and the delivery set are given in the operational documentation for the micromotor.

5.2.4 Piezoelectric scaler



Scaler handpiece

Figure 5.2.4.1

ATTENTION! Do not disconnect the handpiece or handpiece hose while the unit is on.



ATTENTION! The scaler unit does not require additional maintenance, but the components (handpiece cable, tip, files, etc.) should be checked before and after work to detect any damage or insulation defects. Eliminate all malfunctions before starting work.

ATTENTION! The vents of the dental unit must be kept clean to ensure optimal working conditions for the piezoelectric scaler.

1. Preparation for work:

- wear safety glasses and gloves;
- pull out the handpiece, torque wrench and inserts;
- screw the insert into the handpiece, first by hand, and then with a torque wrench (Figure 5.2.4.2 and Figure 5.2.4.3);

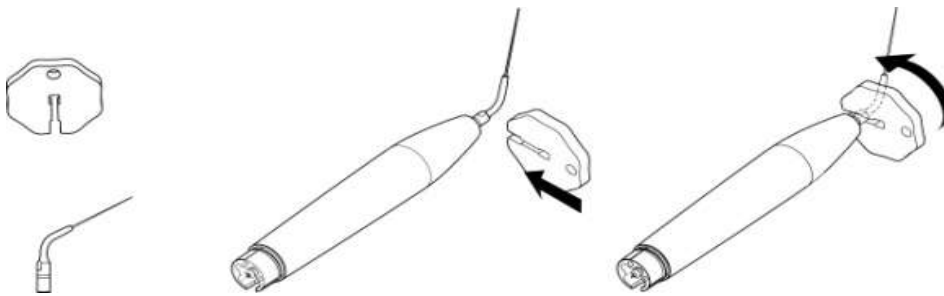


Figure 5.2.4.2



Figure 5.2.4.3



Attention! The handpiece or file must be securely fastened in the holder without excessive pressure. Do not use a flat wrench to secure the handpiece or file as this may damage the handpiece, insert or file.

- connect the handpiece to the hose (Figure 5.2.4.4), when doing so:
 - it is forbidden to rotate the handpiece connector relative to the hose;
 - it is forbidden to wind the hose of the handpiece on medical devices;
 - it is necessary to make sure that the hose does not twist and that no one steps on it;
 - ensure that when performing dental procedures, the hose is in the access zone and is not excessively stretched;
 - make sure that there are no traces of moisture at the junction of the handpiece and the hose;

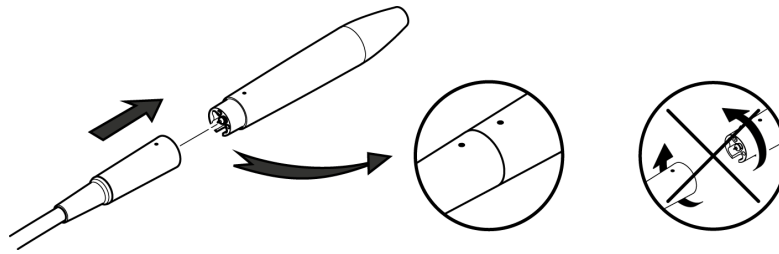


Figure 5.2.4.4

To increase efficiency of the gasket and eliminate leakage, lubricate the gasket of the irrigation system, which is located on the back side of the handpiece on the metal axis, with a silicone paste. It is not recommended to use a spray for lubricating dental instruments.

- take the handpiece of the scaler in your hand and switch on the device;
- check the operation parameters of the irrigation system;

Irrigation may not be used if the following conditions are met:

- the scaler insert is intended for use without irrigation;
- additional devices are used to improve visibility (microscope or magnifying glass);
- work is done in four hands (doctor + assistant);
- place of intervention is always in the field of vision, which reduces risks of overheating;
- any manipulation should last no more than 1 minute;
- local irrigation is used;
- air drying is carried out.



ATTENTION! Doctor must constantly monitor the process - the lack of irrigation should not create risks for the patient.

- **2. Intended use:**
- take off the scaler from the doctor table;

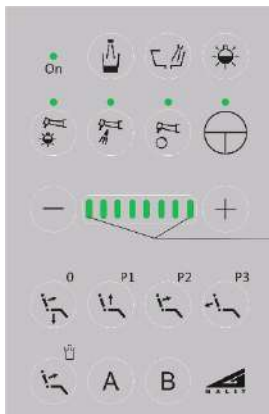





Figure 5.2.4.5

- select the necessary scaler operation mode (**PERIO/SCALING**) on the control panel of the doctor table (Figure 5.2.4.5). (Inserts or files for the scaler must be selected according to the mode of operation of the scaler).

- By buttons  ,  on the doctor table control panel set a required power for the selected operation;

- **if none of the power indicators** on the doctor table control panel lights up, the scaler is ready to work in **PERIO** mode;

- **I-VIII indicators** determine the power range for the mode **SCALING** (Figure 5.2.4.5);

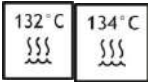
- if necessary, adjust with a knob  intensity of water supply (irrigation) for the instrument;
- press the foot control.



ATTENTION! During start of the scaler at the moment of pressing the foot control, it is strictly forbidden to apply any effort to the handpiece of the scaler. Failure to comply with this requirement may result in damage to the handpiece.

ATTENTION! The doctor must hold the active part of the device - the handpiece - in his hand throughout the duration of the medical procedure.

3. Cleaning, disinfection and sterilization of the handpiece, inserts and files:



- components and handpieces must be cleaned, disinfected and sterilized before each use;

- during cleaning and disinfection operations, the device must be switched off;
- do not immerse the scaler handpiece in water;
- avoid using cleaning and disinfecting agents containing abrasive cleaning agents and flammable components;
- do not spray the cleaning agent directly on the medical device. **Do not wipe contacts.**

4. Cleaning of the irrigation system:

After installation and before starting use, at the end of the working day or if the scaler has not been used for a long time, it is necessary to clean the irrigation system. To do this, switch on the scaler at the minimum power, but with the maximum use of the irrigation spray for 2 minutes.



Be sure to read the operating documentation provided by the scaler manufacturer before starting work, which contains detailed instructions for operation and maintenance, cleaning, disinfection and sterilization of the device.



ATTENTION! The scaler can contain ENDO mode.

To ensure operation of the ENDO mode; a three-position switch is installed in the dental unit.

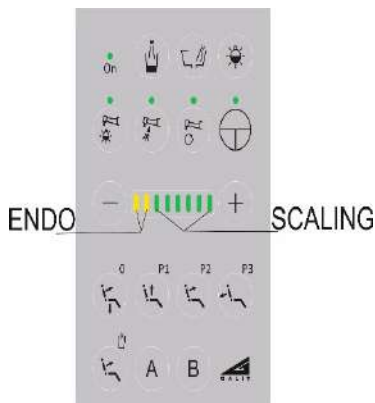


Рисунок 5.2.4.6

- select a necessary mode of operation of the scaler (**PERIO/ENDO/SCALING**) on the control panel of doctor table (Figure 5.2.4.6). (Inserts or files for the scaler must be chosen according to the mode of operation of the scaler).

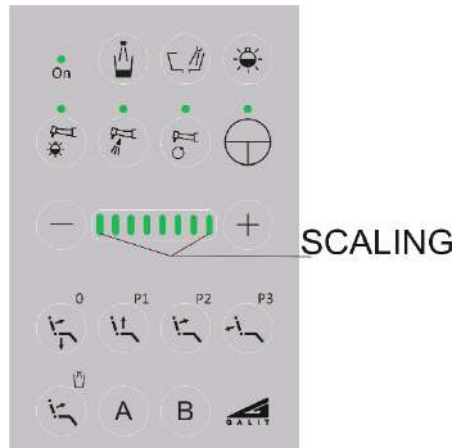
- by buttons \oplus , \ominus on the doctor table control panel set a needed power for the selected operation;
- *if none of the power indicators* on the doctor table control panel lights up, the scaler is ready to work in **PERIO** mode;
- **I-II indicators** determine power range for **ENDO** mode;
- **III-VIII indicators** determine power range for **SCALING** mode (Figure 5.2.4.6);



Figure 5.2.4.7 – structure of the LED scaler

Adjusting the scaler power.

The maximum possible power of the scaler is selected on the control panel.



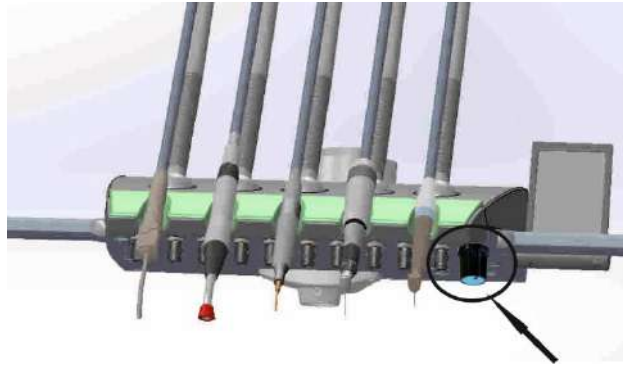
Multifunctional pedal.

The slider on the multi-function pedal adjusts the power of the scaler operating mode in the range specified on the control panel.



Pneumatic pedal.

The potentiometer located on the doctor table regulates power of the scaler in the range specified on the control panel.



5.2.5 Curing Lamp



Fig.5.2.5.1. Curing lamp

To start work, it is necessary to take off the lamp from the holder.

- The curing lamp is turned on and off by pressing the button on the lamp body.
- The lamp switches off if it is not used for 3 minutes. Press On/Off button to start a new cycle.
- The polymerization cycle can be stopped at any time by pressing On/Off button. The lamp switches off if it is not used for 3 minutes. Press On/Off button to start a new cycle.



- The patient and doctor must use special protective glasses.
- Do not expose people with high sensitivity to light to the lamp.
- Do not direct the beam into the eyes.
- The device may interfere with sensitive devices.
- Do not allow composite residue to stick to the optical fibre.
- Do not use the device in a flammable atmosphere.

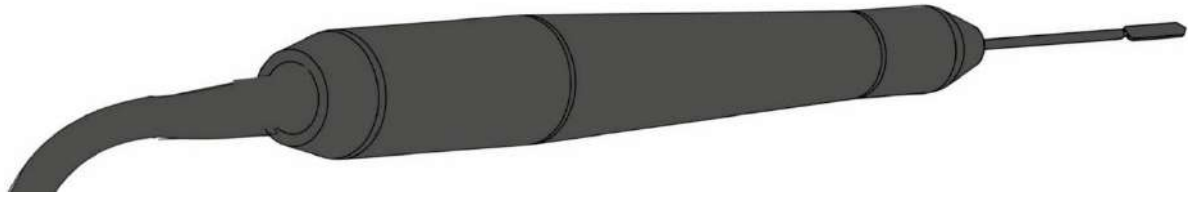
Recommendations for disinfection and sterilization.

- All work on disinfection and sterilization should be carried out only when the lamp is switched off.
- Never spray any liquid directly on the equipment
- Before starting work, the fibre and the light hood must be cleaned and sterile.
- Do not use abrasive products and products with aggressive impurities.





Detailed instructions for operation and maintenance, cleaning, disinfection and sterilization are provided in the operating documentation for curing lamps.

5.2.6 Coagulator



Coagulator operation procedure:

1. Placing coagulator on the doctor table

- Select a required mode of operation with the "COAGULATION/CUTTING" ("КОАГУЛЯЦІЯ/РІЗАННЯ") switch, which is located at the bottom of the doctor table.
- Take off the coagulator from the doctor table.
- Press the foot control.
- By buttons ,  on the doctor table set the required power for the selected gradation "CUTTING" or "COAGULATION". If there are no buttons on the control panel of doctor table, then set the power with the regulator at the bottom of the doctor table, which is on the same axis as the instrument.



ATTENTION! Do not touch metal objects with the cutting element while the coagulator is working. This may cause the coagulator to malfunction.

2. Placing the coagulator on the assistant table

- Select the required mode of operation with the "COAGULATION/CUTTING" ("КОАГУЛЯЦІЯ/РІЗАННЯ") switch, which is located at the bottom of the assistant table.
- Take off the coagulator from the assistant table.
- Press the foot control.
- Set the required power with the regulator located on the bottom of the assistant table



Detailed instructions on the operation and maintenance of the coagulator and the delivery set are provided in the operating documentation for the coagulator.

5.3 Version of "GALLANT DU/DL" dental unit with ENDO option

Dental unit "GALLANT OMNIPRATIQUE" with ENDO option has more advanced functionality compared to other versions and is intended, first of all, for work in the field of endodontics.

The following functions are additional (to the main ones in the standard version):

- 1) smooth and stepwise adjustment of frequency of rotation of the micromotor in normal mode.
The maximum value of the rotation frequency by gradations for this mode is given in table 5.3.1;
- 2) smooth and stepwise adjustment of frequency of rotation of the micromotor in the ENDO mode.
The maximum value of the rotation frequency by gradations for this mode is given in table 5.3.1;

Table 5.3.1. Measurement of maximum rotation frequency of micromotor MC2, "Bien Air" in normal mode and in ENDO mode.

Gradation	Revolutions per minute, $\pm 20\%$ approximate	
	Normal mode	ENDO mode
0	-	550*
I	3700	870*
II	8700	1200*
III	14300	1450*
IV	19700	1630*
V	25050	2100*
VI	30700	2250*
VII	36200	2500*
VIII	42000	2900*

***Note** Reference data.

- 2) operative selection of torque of forward motion, at which the micromotor stops and switches to reverse motion. It is possible to choose one of eight fixed torque values according to Table 5.3.2. This function can be used only in ENDO mode;

Table 5.3.2 Selection of the maximum torque for collector micromotors MC2, ISOLITE, MC3 "Bien Air" in ENDO mode.

Gradation	Torque, N-cm
I	0,3
II	0,6
III	0,9
IV	1,2
V	1,5
VI	1,8
VII	2,1
VIII	2,3

- 3) presence of positive feedback in the micromotor control circuit. The control scheme is built on the basis of a digital pulse width modulator (PWM), which allows you to maintain the frequency
- 4) rotation unchanged when increasing / decreasing the load;
- 5) 8-stage adjustment of the output power of the piezoelectric scaler and (or) diathermocoagulator;
- 6) illumination of instruments with a delay on switching off (8÷10) sec;
- 7) memorization of all final settings of rotation frequency, torque, power level when power is switched off;
- 8) visual display of the established modes of the dental unit as a whole, as well as indication of gradations of rotation frequency, torque and power level;
- 9) sound confirmation of pressing a button on the control panel;
- 10) automatic zeroing in the event of failure of the display on the doctor's unit remote control or failure of the doctor table controller.

5.3.1 Настроювання частоти обертання мікромотора на II - IV робочому місці в нормальному режимі

1. Switch on the power of the dental unit according to location of the main power switch of the unit. At the same time, the normal operating mode is set on the doctor table (see Figure 5.3.1.1).

2. Take off the micromotor from the II - IV workplace of the doctor table.

3. By means of buttons \oplus and \ominus the doctor table control panel set a maximum speed of the micromotor.


Button \oplus increases the rotation frequency, and button \ominus decreases the rotation frequency.

Each indicator of doctor table displays a certain gradation and corresponds to the specified frequency of rotation of the micromotor (in accordance with table 5.3.1.).

For example, I-gradation – one indicator is on - revolutions of the micromotor ~ 3700 rpm.

VIII-gradation – eight indicators are on - revolutions of the micromotor ~ 42000 rpm.

4.a – for pneumatic foot control

Set a knob of one or the both potentiometers  of doctor table to the extreme right position corresponding to maximum rotation frequency of the micromotor and smoothly change the rotation frequency from zero to the maximum value for this value gradation.

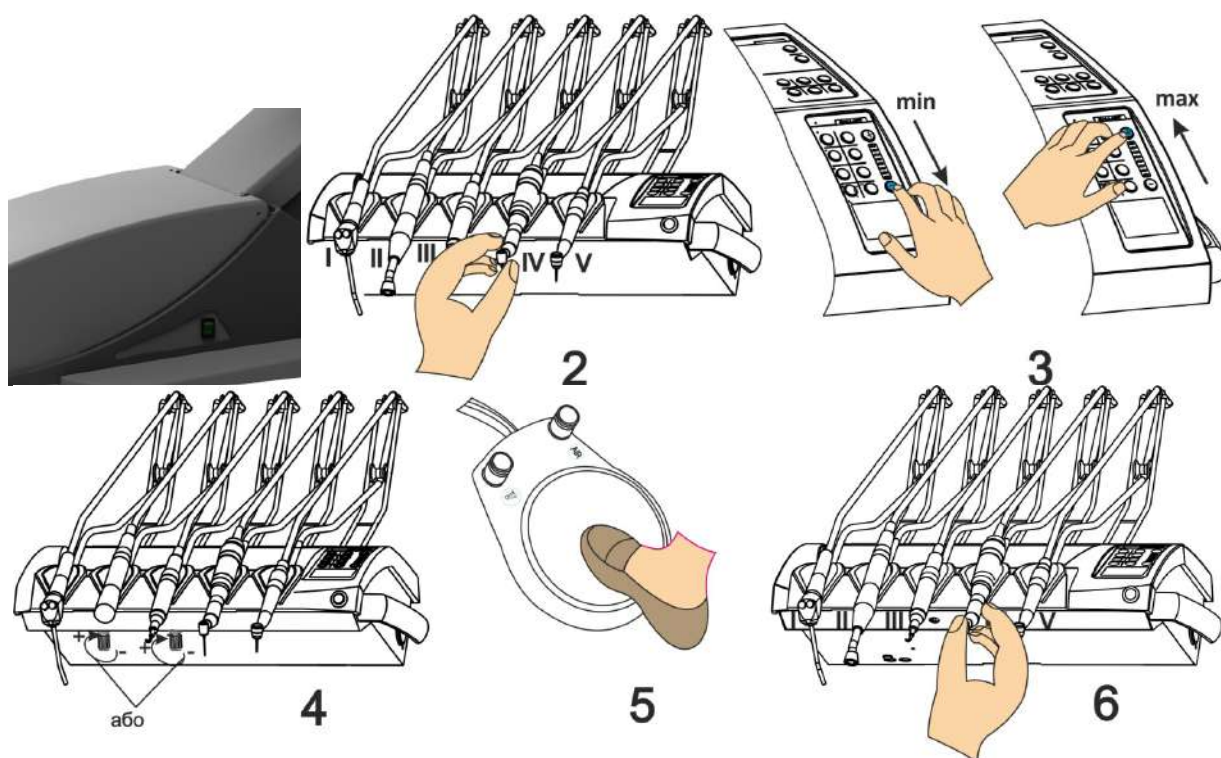


Figure 5.3.1.1 Adjusting the frequency of rotation of the micromotor in normal mode

4.6 – for multifunctional foot control

Set the foot control slider to the extreme right position corresponding to the maximum rotation frequency of the micromotor and smoothly change the rotation frequency from zero to the maximum value for this gradation.

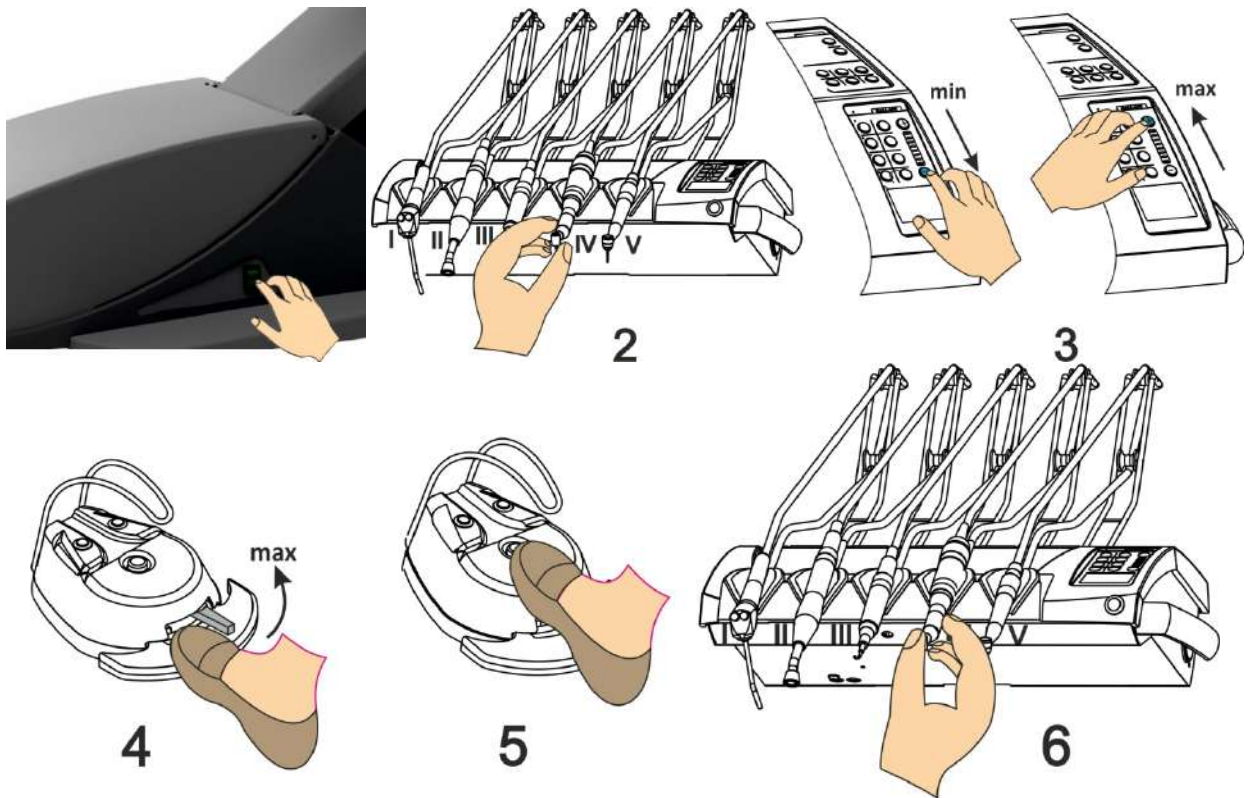


Figure 5.3.1.1 Adjusting the frequency of rotation of the micromotor in normal mode

Figure 5.3.1.2 Adjusting the frequency of rotation of the micromotor in normal mode (multifunctional foot control).

5. Press the foot control and check the set rotation speed of the micromotor.
6. To memorize the set rotation frequency and the corresponding indication, put the instrument down.

5.3.2 Adjusting the rotation frequency of the micromotor in ENDO mode


1. Take off the micromotor from the third workplace of the doctor table (see Figure 5.3.2.1).
2. Press the button to switch on ENDO mode, while the indicator flashes, which means that this mode is set.
3. By means of buttons \oplus and \ominus on the doctor table control panel set frequency of rotation of the micromotor.

Button \oplus increases the rotation frequency, and button \ominus decreases the rotation frequency.

Each indicator of doctor table displays a certain gradation and corresponds to the specified frequency of rotation of the micromotor.

For example, I-gradation – one indicator is on - revolutions of the micromotor \sim 870 rpm.
VIII-gradation – eight indicators are on - revolutions of the micromotor \sim 2900 rpm.

4.a – for pneumatic foot control

4. Set a knob of one or the both potentiometers  of doctor table to the extreme right position corresponding to maximum rotation frequency of the micromotor and smoothly change the rotation frequency from zero to the maximum value for this value gradation.

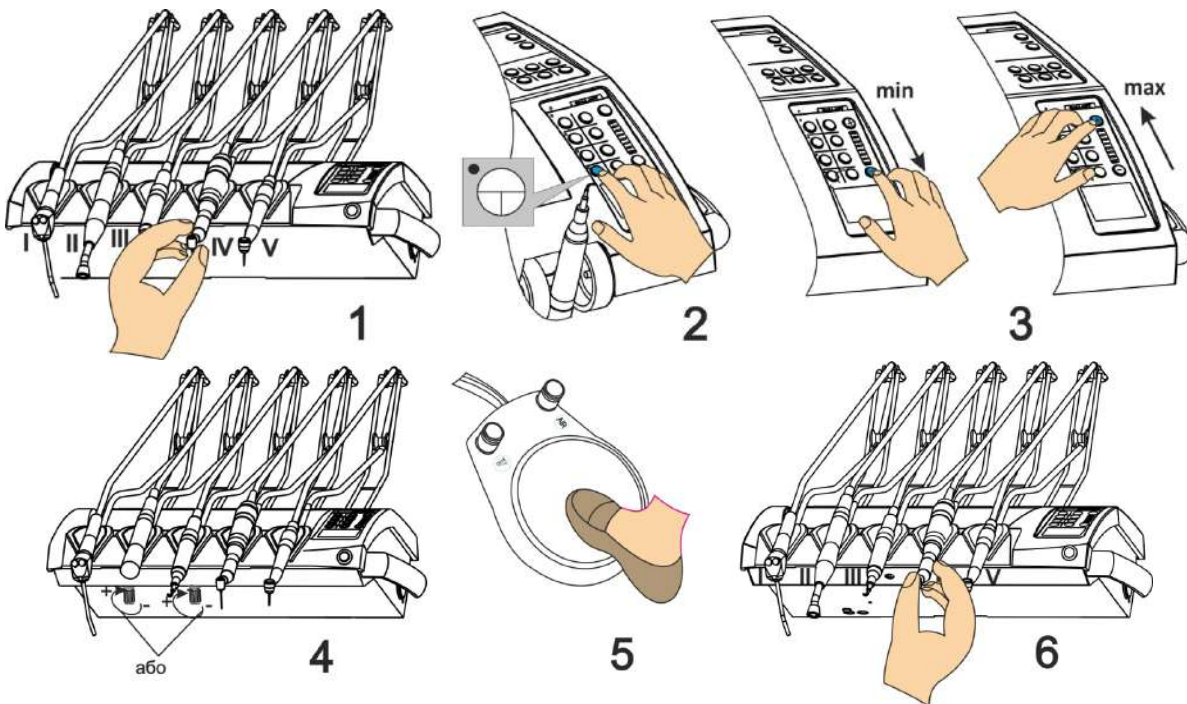


Figure 5.3.2.1 Adjusting the rotation frequency of the micromotor in ENDO mode

4.6 – for multifunctional foot control

Set the foot control slider to the extreme right position corresponding to the maximum rotation frequency of the micromotor and smoothly change the rotation frequency from zero to the maximum value for this gradation.

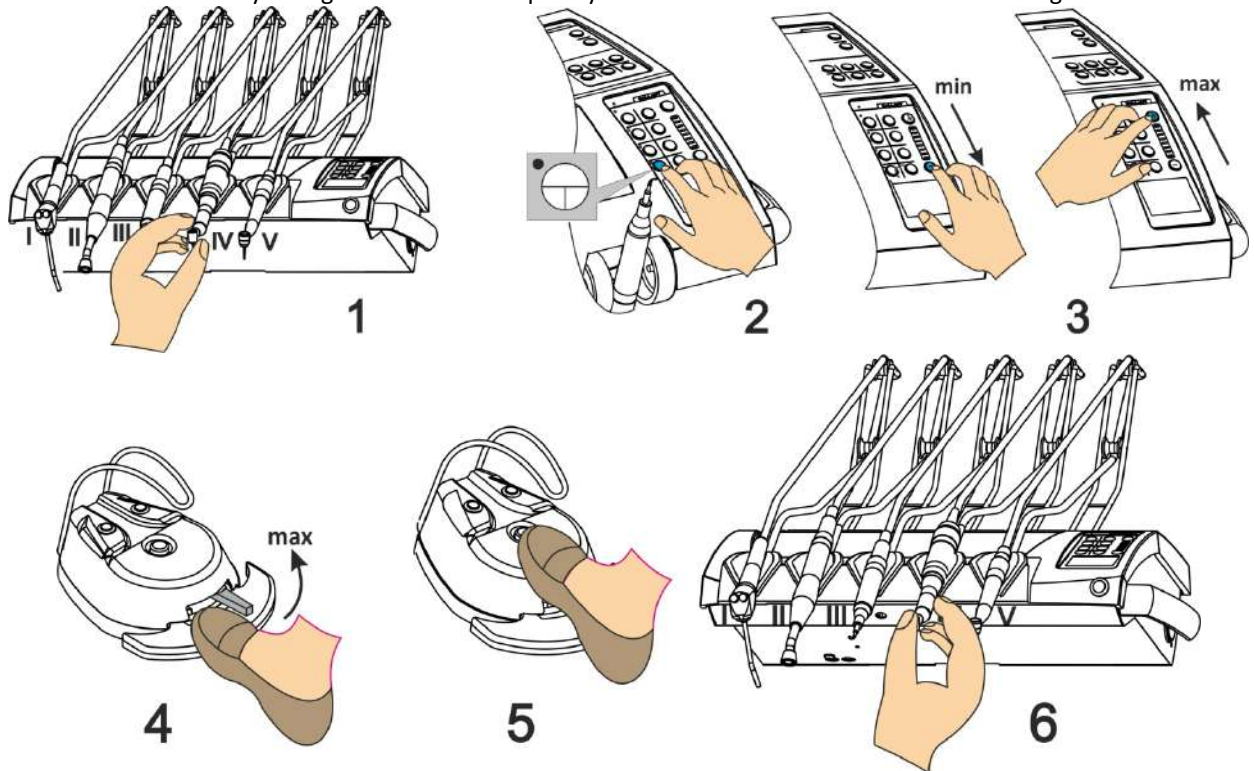



Рисунок 5.3.2.1 Adjusting the rotation frequency of the micromotor in ENDO mode

5. Press the foot control and check the set rotation speed of the micromotor.

6. To memorize the set rotation frequency and the corresponding indication, put the instrument down.

7. ENDO mode is turned off by pressing the button  again.

***Note.**

1. The second micromotor does not work in ENDO mode.
2. Micromotors MX, MX2 in the OPTIMA MX INT or OPTIMA MX2 INT set set are adjustable from the OPTIMA control panel.
3. Micromotors MX2, MCX without the OPTIMA control panel in ENDO mode also do not work.

5.3.3 Adjusting the torque of the micromotor at the III workplace in ENDO mode

1. Press the button to switch on ENDO mode, while the indicator flashes, which means that this mode has been set (see Figure 5.3.3.1).

2. Press the ENDO button again for about 5 seconds and wait for the 8 vertically placed LEDs to blink.

***Note.** If the minimum torque is set, none of the 8 LEDs will blink.

3. By means of buttons \oplus and \ominus on the control panel select a torque value, at which the endofile, encountering a stronger obstacle under real conditions and reaching the selected force, will cause the micromotor to switch from direct to reverse motion.

Removing the obstacle automatically returns the micromotor to direct motion.

Button \oplus increases the torque, and button \ominus decreases the torque.

For normal mode, the maximum torque is 2.3 N·cm.

For the ENDO mode, each indicator of the doctor table displays a certain gradation and corresponds to a fixed torque value.

For example, I-gradation - one indicator lights up - torque \sim 0.3 N·cm.

VIII-gradation - eight indicators light up - torque \sim 2.3 N·cm.

***Note.** Any other operations at the dental unit are not possible at this time. The micromotor also does not rotate.

4. Press the ENDO button again to memorize the torque value. At the same time, the normal mode of operation of the dental facility is established. The ENDO indicator does not flash.

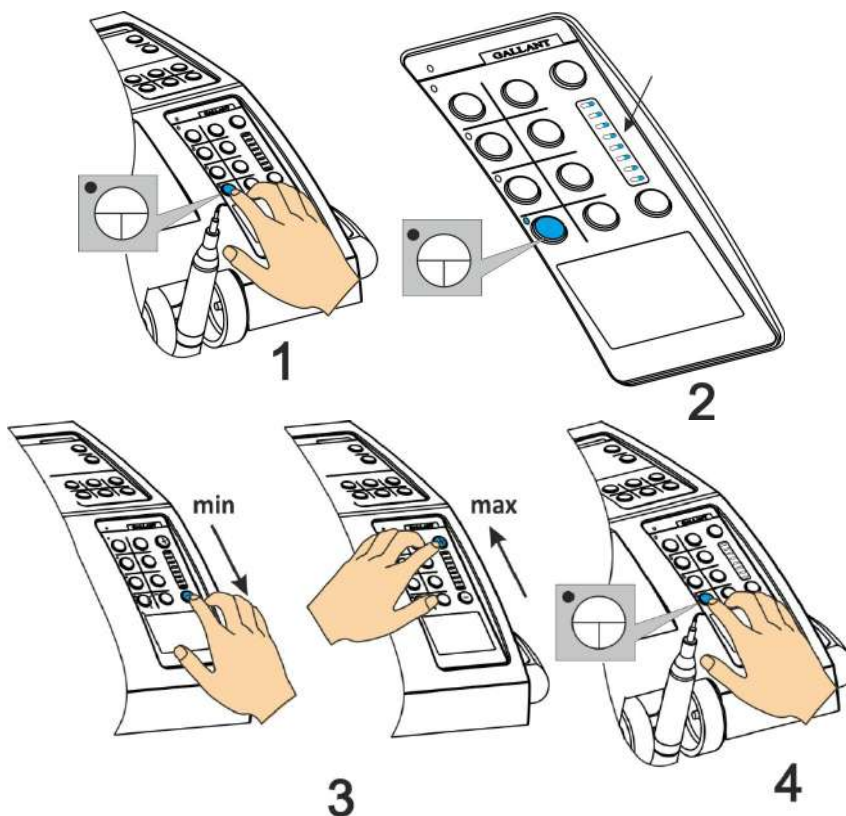


Figure 5.3.3.1 Adjusting the torque of the micromotor in the ENDO mode

6 Assistant Table

On the assistant table there are: water and air saliva extractors, syringe, curing lamp.

To turn on the saliva ejector, you need to remove the instrument from the holder. Disposable saliva ejector tips are not included in the set.

The dust extractor and saliva ejector unit work only with high-speed suction aggregate.

For productive operation of the water saliva extractor, the pressure in the water supply network is not less than 3 bar.



Figure 6.1

6.1 Control panel of the assistant table

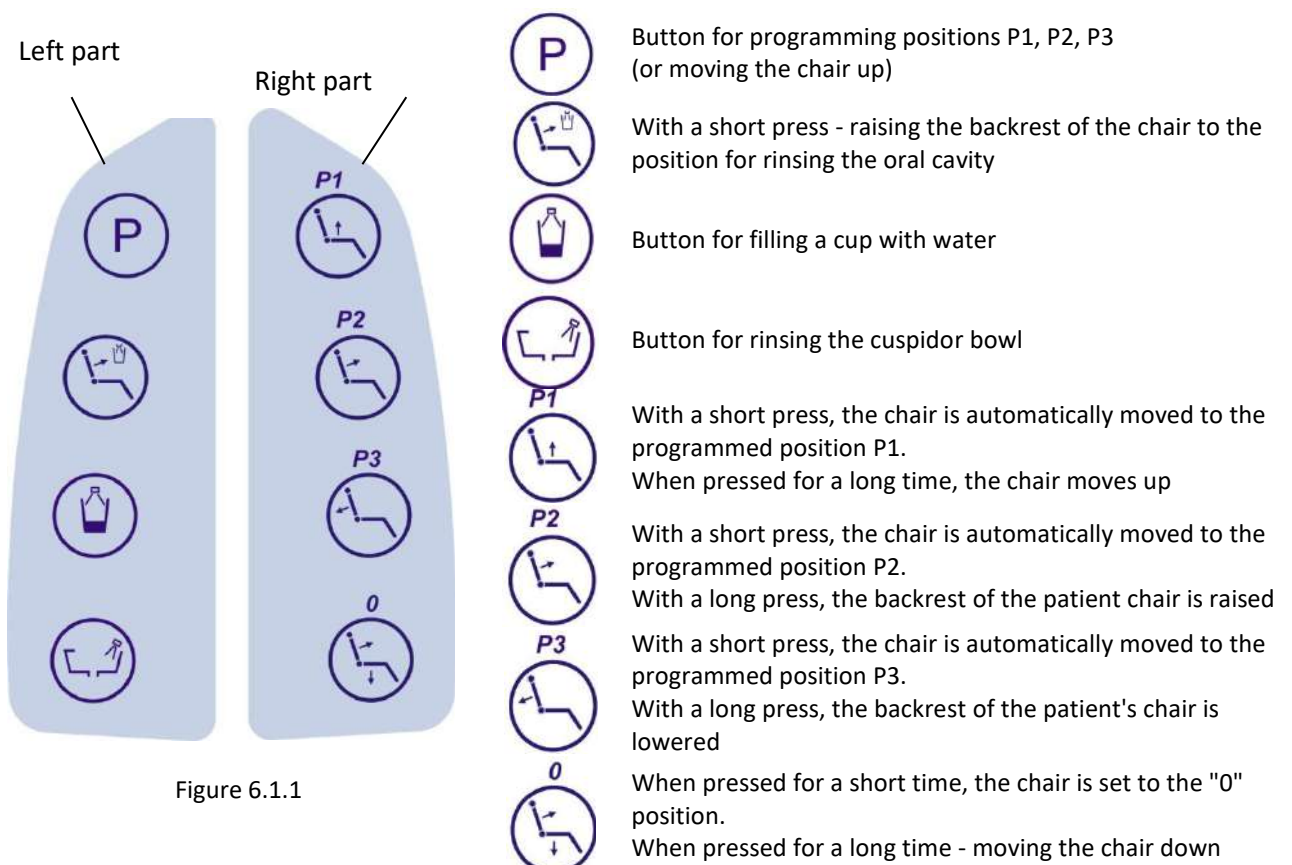


Figure 6.1.1

6.2 Adjusting working modes of instruments on the assistant table

If there are working instruments (diathermocoagulator, curing lamp, scaler, etc.) on the assistant table, the working modes for them are set similarly to clause 5.2. "Regulation of the working modes of instruments on the doctor table".

6.3 Programming working positions of the dental chair




1. Move the chair to the zero position by briefly pressing button .
2. Select the desired position of the chair, which must be assigned, for example, to the P1 program.
3. After that, while holding down the P button, briefly press the P1 button. A sound signal will confirm that the working position is entered into the memory.
4. Later, by briefly pressing the P1 button, the chair will automatically move to the programmed position.
5. In the same way, the working positions for buttons P2, P3 are programmed.
6. Functions of buttons on the control panel of the assistant table correspond to functions of the joystick of the patient chair. The P button on the control panel of the assistant table corresponds to M button on the side of the chair (see Figure 6.2.1).



Figure 6.3.1a- ECO NEXT.

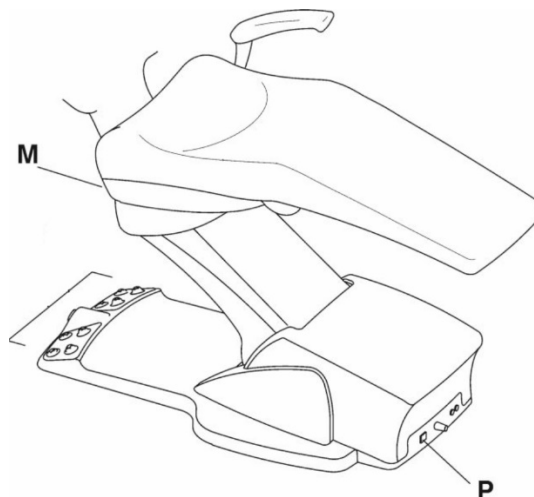


Figure 6.3.16- ECO 19.

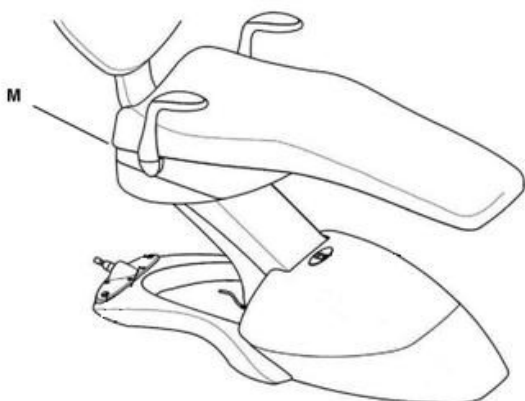
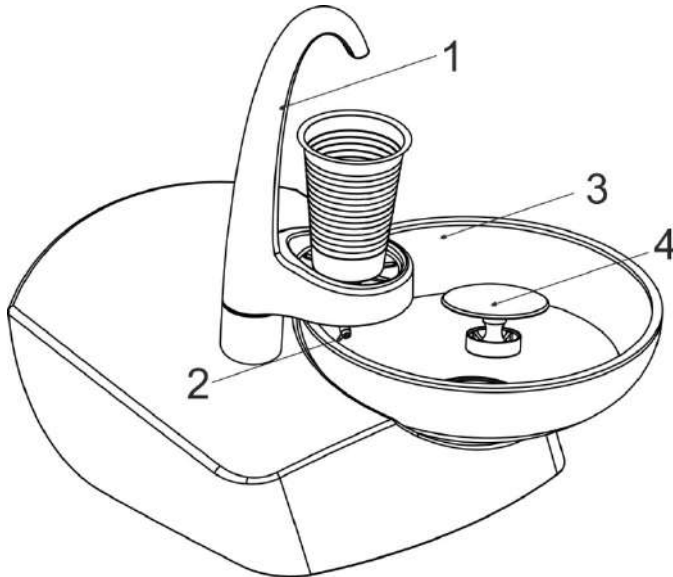


Figure 6.3.1B- STING

***Note.** Programs P1, P2, P3 work only with STING, ECO NEXT, ECO 19 chairs (with programs) and other chairs in which the T2000 control board is installed.

7 Water Unit



7.1 Functions of filling the cup and rinsing the cuspidor



- 1- Cup filling;
- 2- Cuspidor bowl rinsing;
- 3- Cuspidor;
- 4- Filter.

Figure7.1.1

Functions of filling the cup with water and rinsing the cuspidor bowl are activated by pressing the corresponding buttons on the control panel of doctor or assistant:

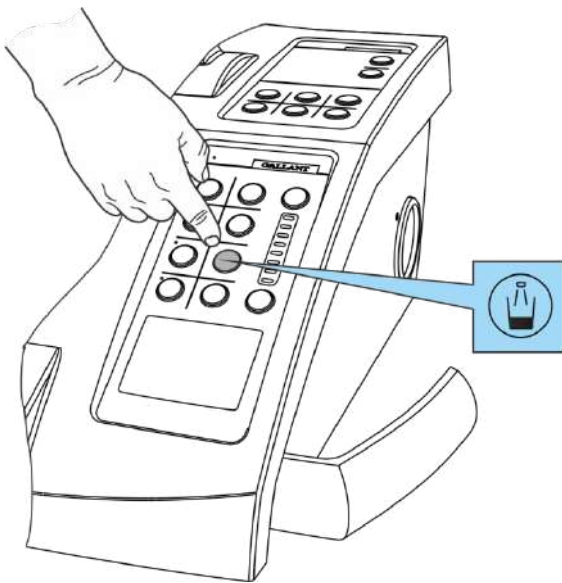
- when pressing the **cup filling button**  on the control panel of doctor table or on the assistant table control panel (for versions with the assistant table control panel) - water enters the cup within 3 seconds or as long as the control button is pressed. If you press the control panel button again before 3 seconds, water supply to the cup stops;
- **in case of need, the cup filling time can be increased (see Section 7.2 Programming the glass filling time);**
- when pressing the **bowl rinsing button**  on the control panel of doctor table or on the assistant table control panel (for versions with the assistant table control panel) – the bowl is being rinsed for approximately 10÷12 seconds. or as long as the control button is pressed. If you press the remote control button again before (10-12) seconds, the bowl rinse stops.
- **In case of need, the cuspidor rinsing time can be increased (see Section 7.2 Programming the cuspidor rinsing time).**



Do not pour liquids into the cuspidor when the unit is switched off.

7.2 Programming time of filling cup and rinsing cuspidor

Cup filling programming time



1. Time of filling the cup is remembered when the cup button is pressed for a long time (more than 3 sec).



>3 sec.

2. When pressing the button for a short time (less than 3 seconds), the cup activates the last memorized time value. **By default**, time for filling the cup is 3 seconds.



<3 sec.

3. If the button is briefly pressed again before the memorized time, filling stops.

4. All settings are saved in the energy independent memory of the microcontroller after the unit is turned off.

Bowl rinsing programming time

5. Rinsing time of the cuspidor is memorized when the rinsing button is pressed for a long time (more than 3 seconds).

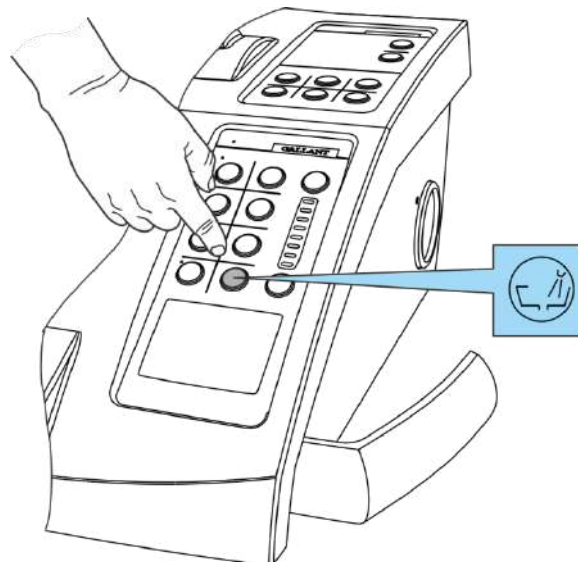


>3 sec.

6. When the button is pressed for a short time (less than 3 seconds), the last memorized time value is activated. **By default**, the time for rinsing the cuspidor is 10 seconds.

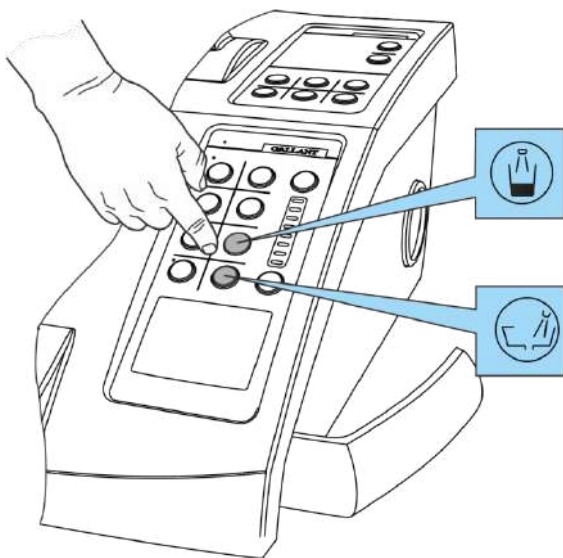


<3 sec.



7. If the button is briefly pressed again before the memorized time, rinsing stops.

8. All settings are saved in the energy independent memory of the microcontroller after the unit is turned off.



9. За потреби можна відновити початкові (“заводські”) значення часу наповнення склянки **3 сек** і часу змиву плювальниці **10 сек**.

Для цього потрібно виконати наступну **послідовність** дій:

- натиснути **одночасно** кнопки змиву і наповнення склянки;
- ввімкнути стоматологічну установку.



10. **Максимальне** програмоване значення часу змиву або наповнення – **33 сек**.

7.3 Memorization of "spray" and "illumination" modes for I-IV instruments

For I-IV instruments, the "spray" and "illumination" modes are memorized for each instrument separately. All settings are stored in the energy independent memory of the microcontroller.

Adjustment of "spray" and "illumination" modes for I-IV instruments:

1. Take off the instrument from the holder.
2. Switch on (or switch off) "illumination" of the instrument. Indicator is on – "illumination" is on.
3. Switch on (or switch off) "spray" for instruments cooling. Indicator is on – "spray" is on.
4. Insert the instrument in the holder.
5. **When the instrument is taken off from the holder again, the "spray" and "illumination" mode will be the same as when the instrument was last used.**

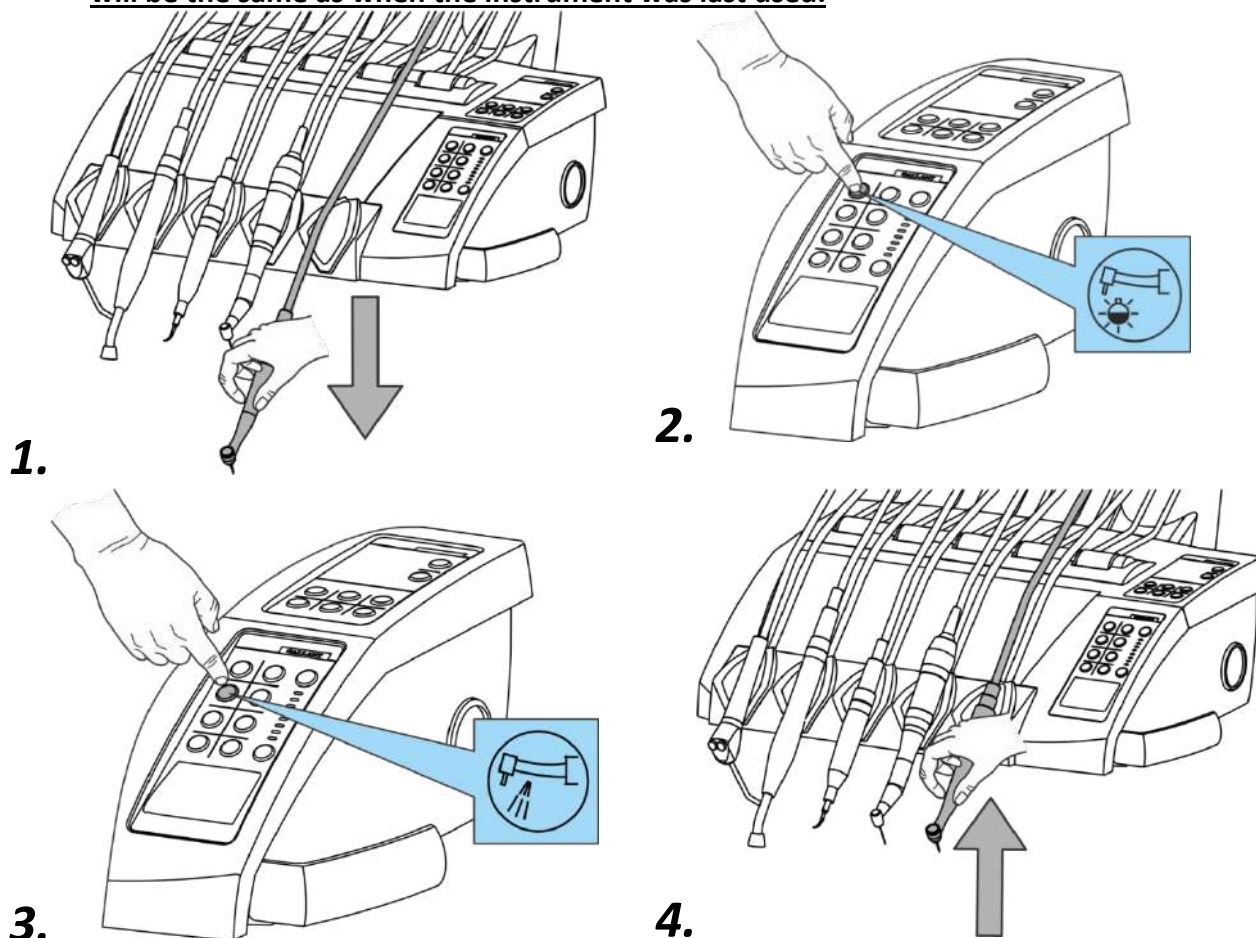


Figure 7.3.1

When the instrument is operating in "SPRAY" mode, after releasing the foot control, the water-air mixture stops being supplied to the instrument. Then, with a pause of 0.5 seconds, water is blown out from the "spray" channel for 1 second.



ATTENTION! Function of blowing out water after releasing the foot control can be disabled or re-enabled. It is recommended to configure this function with the involvement of a qualified technician or a representative of the PC Galit service department.

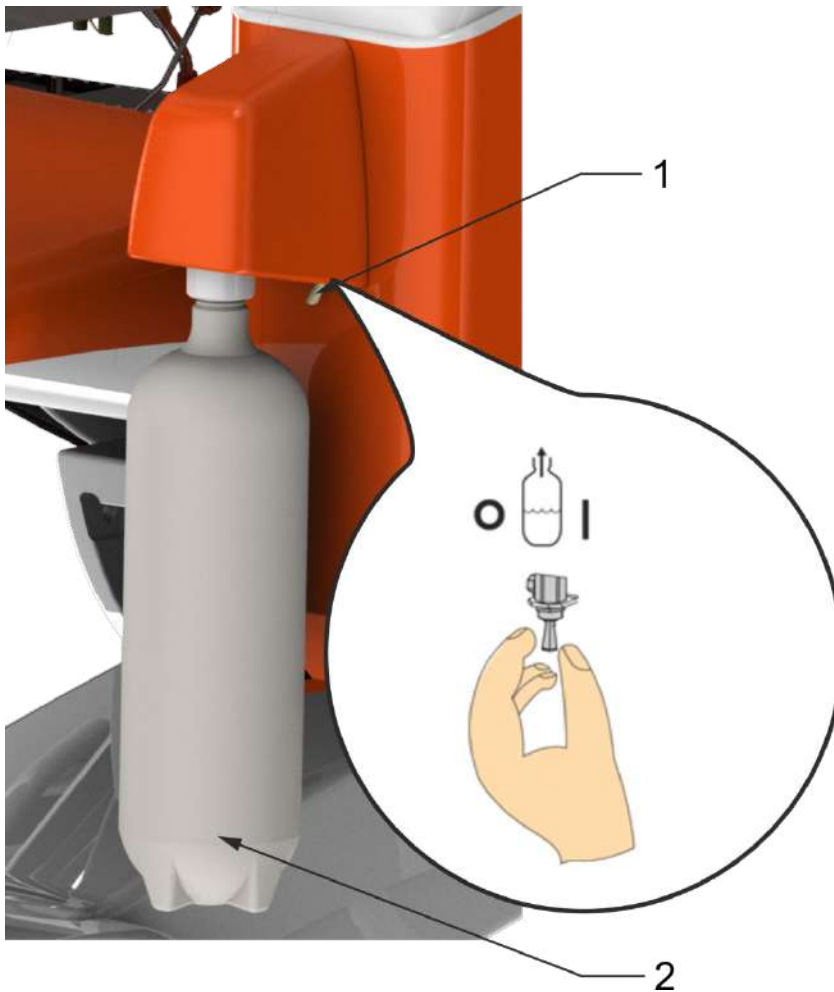
Notes.

1. The "illumination" memory function is **turned on** by DIP switch 4 to ON position.
2. The "illumination" memory function is **turned off** by DIP switch 4 to OFF position in case of using micromotors MCX and MX2 of "Bien Air" company.
3. Regardless of DIP switch 4 position, the function is disabled for scaler at IV.

7.4 Distilled Water System (DWS)

Filling the distilled water system with a bayonet connection:

- turn off the air supply switch **pos. 1** into the distilled water system (Fig.7.4.1);
- unscrew the water container **pos. 2**. **To do this, turn the water container to stop and pull it down (Fig.7.4.2);**
- pour distilled water into the container;
- install the container with water in the holder. **To do this, install the filled water container on the upper part of the bayonet connection and rotate until it is fully fixed;**
- turn on the air supply switch to the distilled water system (top position of the switch).



1 – the switch to supply air into the distilled water system,
2 – container for water with bayonet connection.

Figure 7.4.1

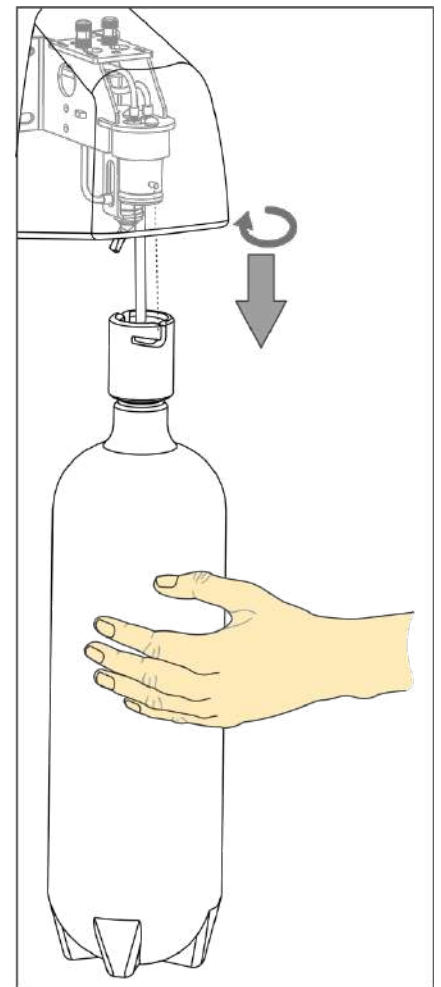


Figure 7.4.2

ATTENTION! In order to prevent contamination of channels of hydraulic system of the unit and the hydraulic system of the instruments, fill the container only with distilled water. Presence of continuous hissing around the neck of the container with water indicates a leak. To eliminate leakage, tighten the container or replace the gasket.



Use the water bottle carefully. Always check the bottle for damage before filling it and every time it is dropped. If cracks or other signs of damage are found, stop using the bottle immediately and replace it with a new one.



To disinfect the distilled water system, use FD 322 from Durr Dental GmbH & Co. KG", or use disposable bottles.

8 Maintenance

8.1 Recommended products for care, cleaning and disinfection

ATTENTION! It is **STRICTLY** forbidden to use solutions containing **CHLORINE** for disinfection of dental equipment!

It is **RECOMMENDED** to use disinfectants of Durr Dental, Orochemie and METASYS companies.

ATTENTION! Perform maintenance work only after turning off the equipment.



ATTENTION! It is forbidden to pour or spray solutions directly on the surface of the unit to prevent them from getting inside.

Before processing sensitive surfaces, check compatibility of materials with disinfectants in an inconspicuous place.

ATTENTION! Before use, be sure to read the labelling and information about the product that will be used for cleaning and disinfection.

The materials of which the unit is made provide convenient and easy cleaning and disinfection.

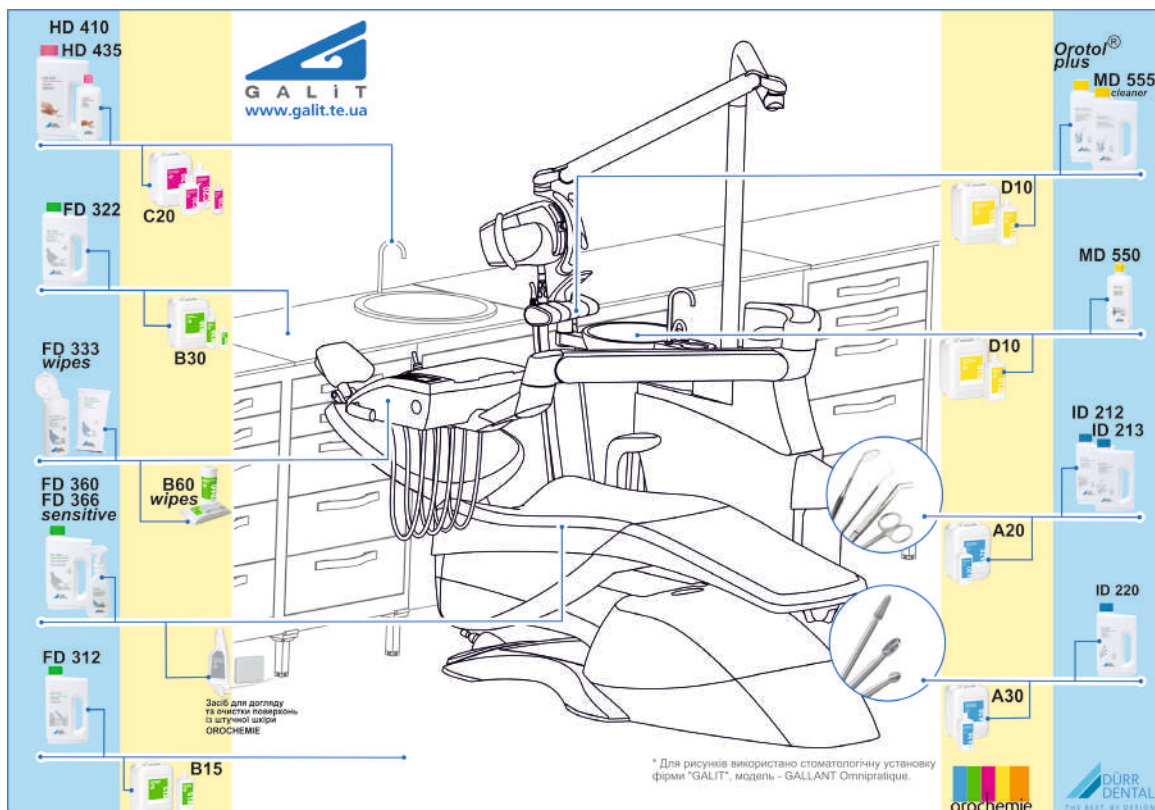
Use only a soft cloth moistened with a cleaning or disinfecting solution.

Use disinfectants only as intended, in accordance with the recommendations provided by manufacturers of disinfectants and dental equipment.




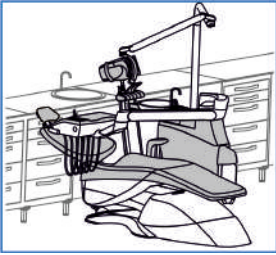

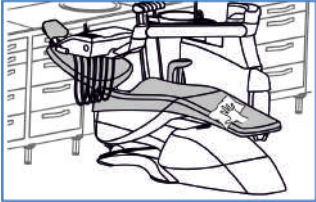


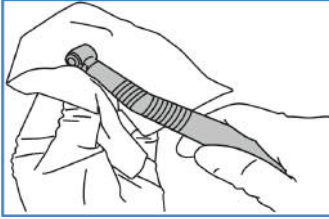























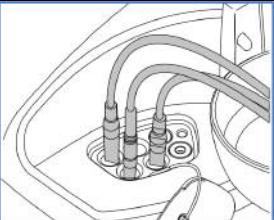

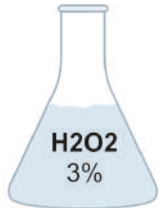
National hygiene and disinfection requirements and recommendations must be followed, e.g. B. Robert Koch Institute (RKI), American Dental Association (ADA), Centers for Disease Control and Prevention (CDC), etc.

Scheme of disinfection with the use of means "Durr Dental GmbH & Co. KG" and "Orochemie GmbH + Co. KG"
(only for Ukraine);



Products recommended for cleaning and disinfection care (*only for Ukraine*)

		Durr Dental GmbH & Co. KG	Orochemie GmbH + Co. KG
	Quick disinfection of surfaces	 FD322	 B30
	Disinfection of delicate surfaces, for example, plastic, vinyl upholstery, displays, acrylic glass	 FD366	
	Cleaning and care of vinyl upholstery	 FD360	 Facility for cleaning and care of artificial leather products Orochemie * <small>* Do not use special sponges to clean the skin.</small>
	Disinfection of dental handpieces	 FD333 wipes	 B60
	Disinfection of intraoral camera	 FD350 wipes	
	For disinfection and cleaning of instruments	 ID212 ID213	 A20

	<p>For disinfection and cleaning of rotating instruments (including burs, cutters and drills)</p>	 <p>ID220</p>	 <p>A30</p>
	<p>For disinfection and cleaning of suction systems and cuspidors</p>	 <p>Orotol® plus MD555</p>	 <p>D10</p>
	<p>For disinfection and cleaning of cuspidors</p>	 <p>MD550</p>	
	<p>For disinfection of surfaces (floors, walls, etc.)</p>	 <p>FD 312</p>	 <p>B15</p>
	<p>Hand disinfection and cleaning</p>	 <p>HD 410 HD435</p>	 <p>C20</p>
		<p>METASYS Medizintechnik GmbH</p>	<p>Hydrogen peroxide 3%</p>
	<p>For internal hose channels and unit water ways</p>	 <p>GREEN&CLEAN WK</p>	 <p>H2O2 3%</p>

Detailed information on these disinfectants can be obtained from the website of the product manufacturers:

- 1) www.duerrdental.com - site of company Durr Dental GmbH & Co.;
- 2) www.orochemie.de/ - site of company "Orochemie GmbH + Co. KG";
- 3) www.metasys.com - site of company Metasys.

8.2 Care of instruments

Constant care is necessary for the perfect functioning of each instrument. This is simple care and is provided by special means. Lubrication and maintenance of instruments should be carried out together with cleaning, disinfection and sterilization.



For each specific instrument, it is necessary to use means and recommendations that are indicated in the passport (instructions) for this instrument. Use of other means, not specified in the passport (instructions) or not agreed with the Galit company, voids the warranty for this instrument.

Bien-Air instruments care products:

Cleaning

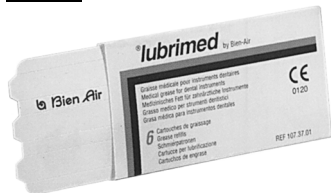


Spraynet (order code REF 1600036-006) aerosol with cleaning agent for instruments and devices. It is recommended to use before sterilization. Dissolves and rinses even heavy pollution.

For cleaning and maintenance of hoses, cables and surfaces of devices, as well as electric micromotors, it is recommended to use a napkin well moistened with Spraynet cleaning agent. Spraynet aerosol is suitable for cleaning all turbines, straight and angular handpieces, as well as air motors and electric micromotors without angular brushes.

All instruments cleaned from the inside with Spraynet must be lubricated before sterilization and storage.

Grease



Lubrimed (order code REF 1600037-006) medical consistency grease for bearing turbines. Greasing of the turbine head is carried out with Lubrimed greasing instrument (order code REF 1000003-001). Instruments must be greased before each sterilization or at least twice a day.

Lubrication



Lubrifluid (order code REF 1600064-006) is an aerosol for lubricating contra angles, air motors and electric micromotors.

Sterilization

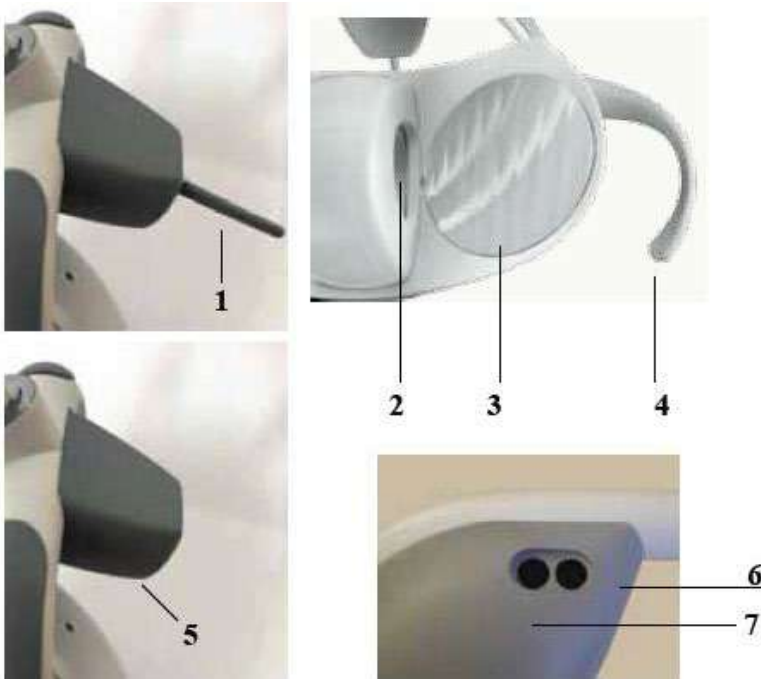
- in an autoclave up to 136 °C / 2.2 bar for 10-30 minutes;
- by ethylene oxide at 60°C;
- drying cycle: maximum 136 °C for a maximum of 30 minutes

Detailed recommendations and rules for the care of instruments are presented in the passport (instructions) for this instrument.

Detailed recommendations for use of instruments care products are presented in the instructions for using these instruments.

8.3 Lamp (dental)

8.3.1 Lamp (dental) MAIA



- 1- Switch
- 2- Lens
- 3- Parabolic mirror
- 4- Handle
- 5- Contactless switch
- 6- Fuses
- 7- Transformer

Each time the lamp is turned on, the light intensity will be at the level that was set before the lamp was turned off.

Lighting intensity is regulated using a switch or a contactless switch (depending on the design of the lamp) .

The contactless switch allows you to turn on or off the lamp without direct contact, thus eliminating possibility of cross-contamination (depending on the design of the lamp).

1. Lamp "MAIA", version with joystick

- To turn the lamp on and off, press and release the regulator lever on the left or right side.
- Light intensity adjustment:

The lamp is switched on at maximum intensity.

To decrease the light intensity, press and hold the control lever on the left side (rear view of the lamp) until the desired light intensity is reached. This control switch does not allow you to increase the intensity of the light.

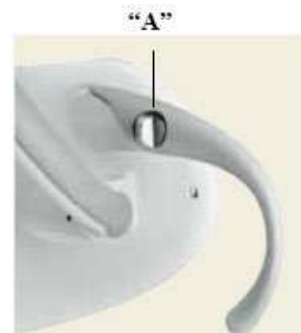
2. Lamp "MAIA", version with contactless sensor

- To turn on or off the lamp, approach the sensor at a maximum distance of 3 cm.
- To adjust the light intensity, stay close to the sensor.

3. Sterilization of lamp handles

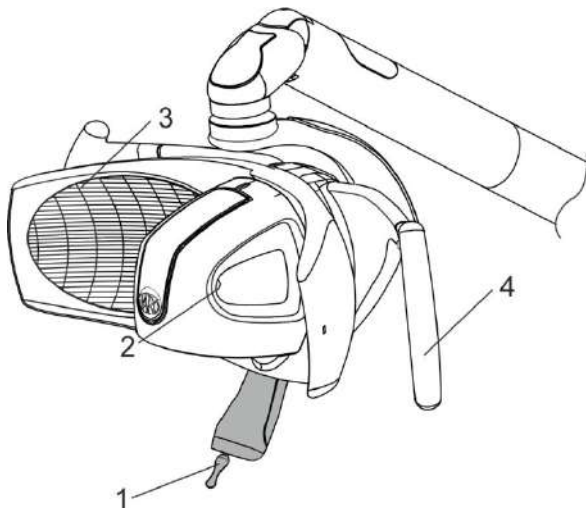
Press "A" button and remove the handle. When installing the handles back, press them as far as they will go.

Handles are delivered in a non-sterile state, the handles must be sterilized before use.



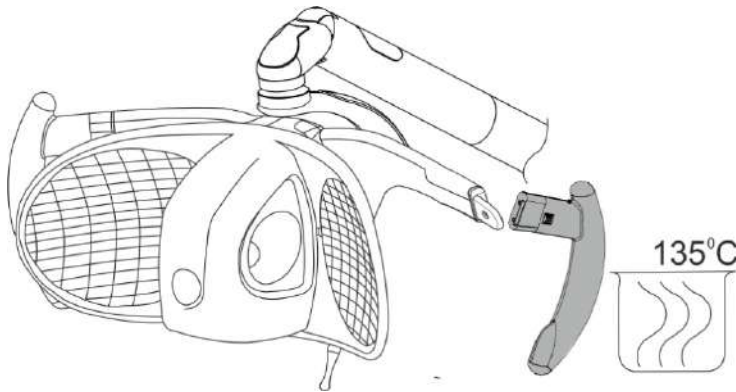
Detailed information on the operation and maintenance of the lamp is given in the "Instructions for the dental lamp", which is included in the delivery set of the unit.

8.3.2 Lamp (dental) ALYA



- 1 – Switch
- 2 - LED
- 3 - Parabola
- 4 – Handle

Sterilization of lamp handles Press «A» button and remove the handle. When installing the handles back, press them as far as they will go.



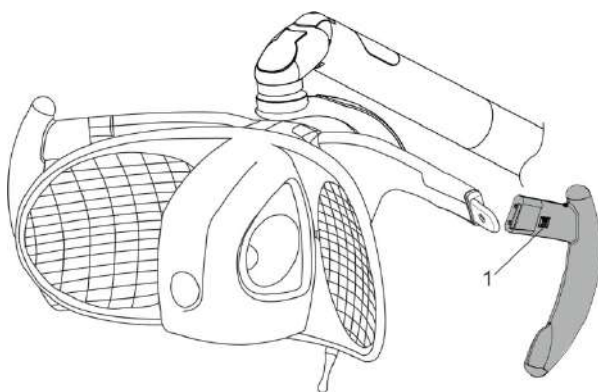
Handles can be sterilized at a standard cycle of 121° / 134° maximum 200 times.

Cleaning of parabolas (pos. 3).

Clean with cotton wool and ethyl alcohol. Do not use detergents that contain surfactants or water repellents that can leave stains.

ON/OFF:

- To turn on and off, press and release the button. Hold this button to adjust the intensity.



Handles removal

- Put your hands on the buttons.
- Press the buttons simultaneously and disconnect the handles.
- Install the handles on both sides at the same time and press them.



Detailed information on the operation and maintenance of the lamp is given in the "Instructions for the dental lamp", which is included in the delivery set of the installation.

8.3.3 Lamp (dental) EVA



- 1- the handles are removable and autoclavable.
- 2- a bright diode on the lamp immediately shows the level of illumination and colour temperature.
- 3- 3D rotation of the lamp > 360° to illuminate every part of the mouth.
- 4- safe and comfortable to hold.

Lighting intensity is regulated using a switch or a contactless switch (depending on the design of the lamp).

The contactless switch allows you to turn on or off the lamp without direct contact, thus eliminating the possibility of cross-contamination (depending on the design of the lamp).

1. Lamp "EVA", version with joystick

- To turn the lamp on and off, press and release the regulator lever on the left or right side.
- Light intensity adjustment:

The lamp is switched on at maximum intensity.

To decrease the light intensity, press and hold the control lever on the left side (rear view of the lamp) until the desired light intensity is reached. This control switch does not allow you to increase the intensity of the light.

2. Lamp "EVA", version with contactless sensor

- To turn on or off the lamp, approach the sensor at a maximum distance of 3 cm.
- To adjust the light intensity, stay close to the sensor.

3. Sterilization of lamp handles

Press the button and remove the handle. When installing the handles back, press them as far as they will go.

Handles are delivered in a non-sterile state, the handles must be sterilized before use.



Detailed information on the operation and maintenance of the lamp is given in the "Instructions for the dental lamp", which is included in the delivery set of the installation.

8.4 Cleaning the cuspidor filter

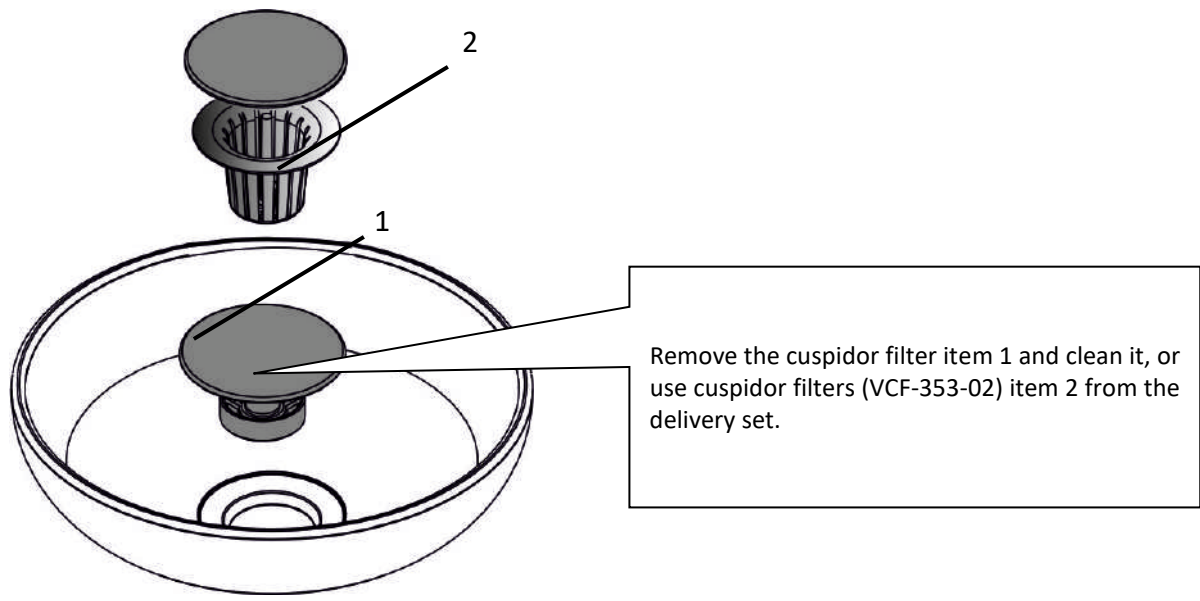


Figure 8.3.1

8.5 Cleaning the exhaust air filter of pneumatic outlets

It is necessary to do the following to clean the exhaust air filter: unscrew and remove the cover; if necessary, replace the paralon disc.

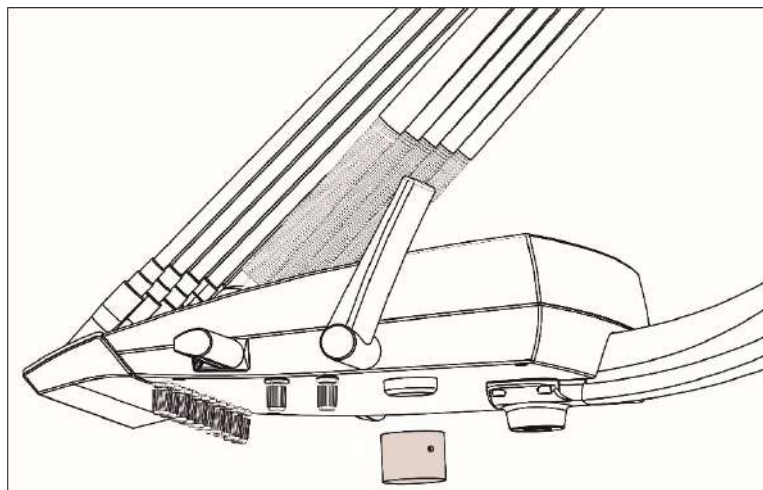


Figure 8.5.1

8.6 Draining condensate from the unit

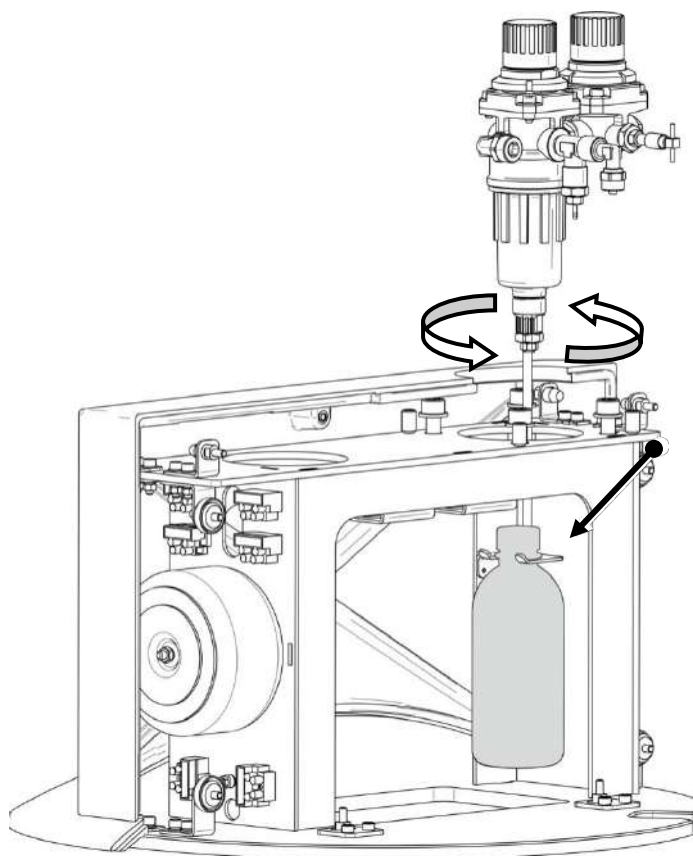


Figure 8.4.1

When the air pressure in the unit system decreases to less than 1 bar - the fine air filter valve opens and the condensate that collects in the filter is automatically drained into the container.

If necessary, draining of condensate is allowed to be carried out forcibly, for this purpose:

- lift the filter valve up;
- completely drain the condensate;
- turn the filter valve (Figure 8.4.1).

Periodically when filling the collection container - drain the condensate.

Codes of filtering elements for ordering:

Fineness of filtration	Code
25 microns	C104-F20/3 Camozzi
5 microns	C104-F21/3 Camozzi
0,01 microns	C104-F26 Camozzi

8.7 Cleaning the exhaust air filter of pneumatic outlets

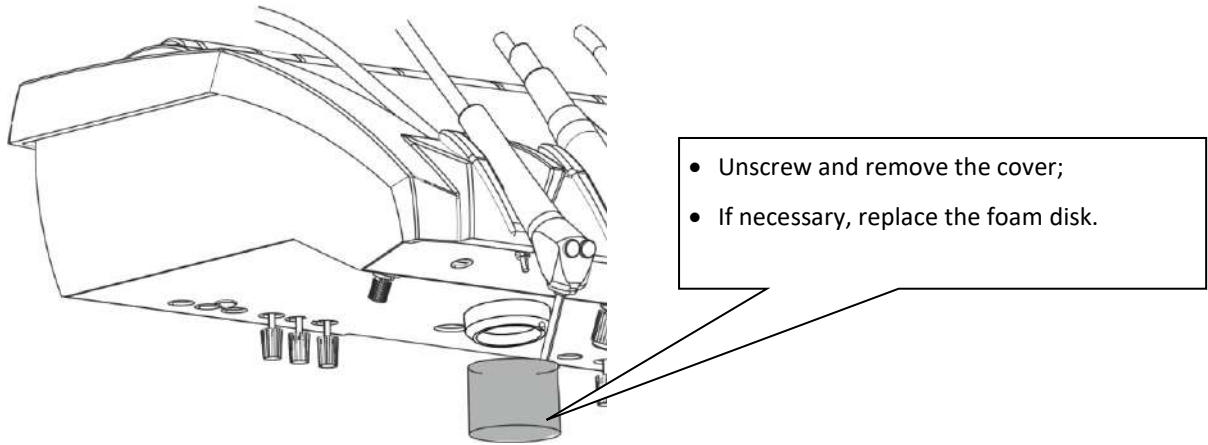


Figure 8.5.1

8.8 Coarse cleaning filter

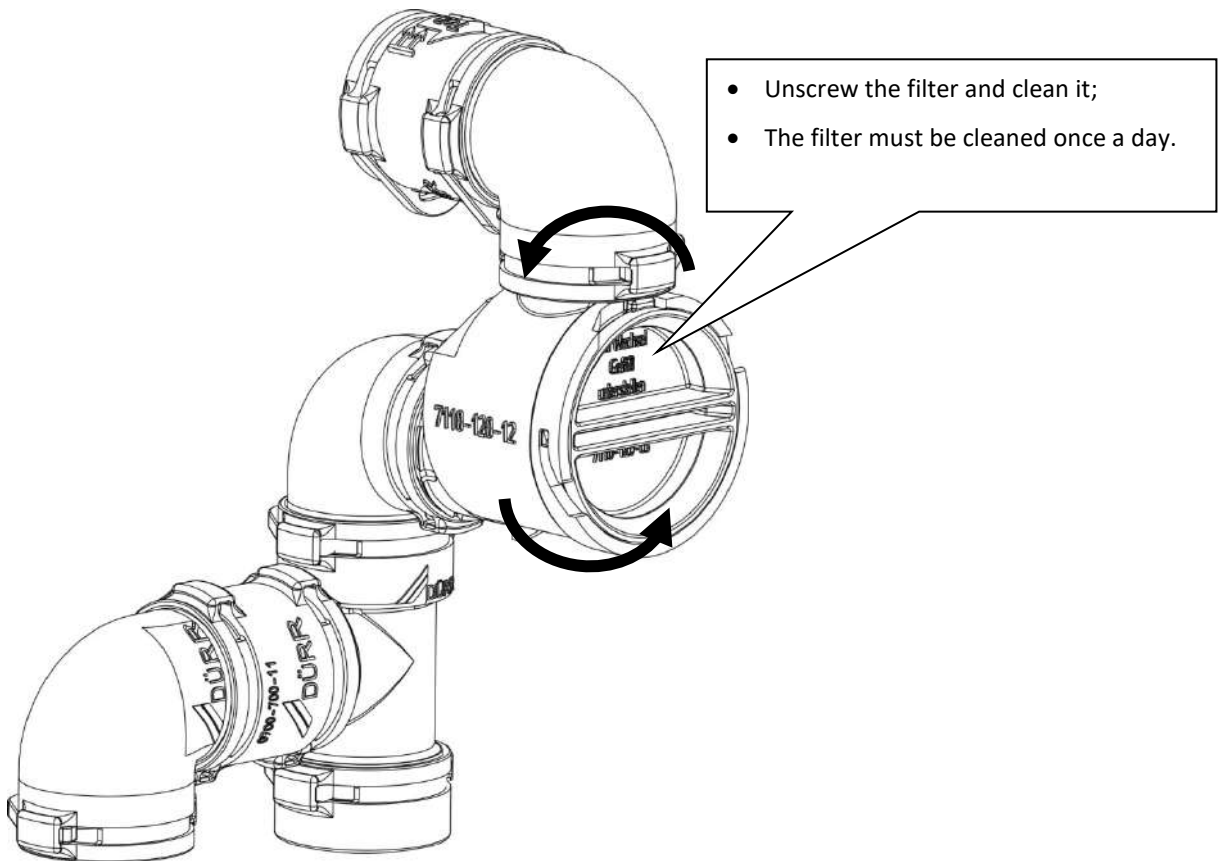


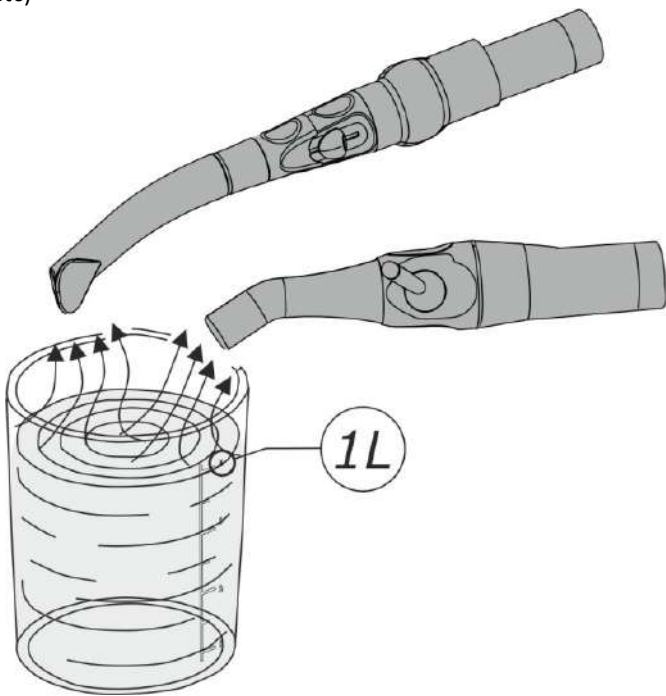
Figure 8.6.1

8.8.1 Maintenance of the aspiration system

The aspiration system includes:

- terminals of saliva ejector and dust extractor (the parts where the saliva ejector and dust extractor disposable pipes are installed);
- hoses of saliva ejector and dust instructor;
- the system connecting hoses;
- selection valve;
- cuspidor valve;
- filter (point 8.8.1) in housing;
- separator.

For simultaneous disinfection, cleaning, deodorization and care of suction dental systems, it is necessary to use means "Durr Dental GmbH & Co. KG" Orotol-Plus. Working solutions of these preparations carry out automatic long-term and safe cleaning. With daily use, they ensure the technical and hygienic level of operation of suction dental systems even in the presence of high contamination with microbes and significant contamination (saliva, amalgam and dental dust, blood, etc)



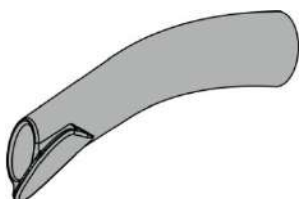
In accordance with the intensity of work of the suction dental system, disinfection and cleaning are carried out **1-2 times a day**. Mandatory disinfection and flushing of the system is carried out **at the end of the work shift**.

1. After receiving **each patient**, draw 1 litre of clean tap water by immersing the saliva ejector and dust extractor cannulas in the container with water.



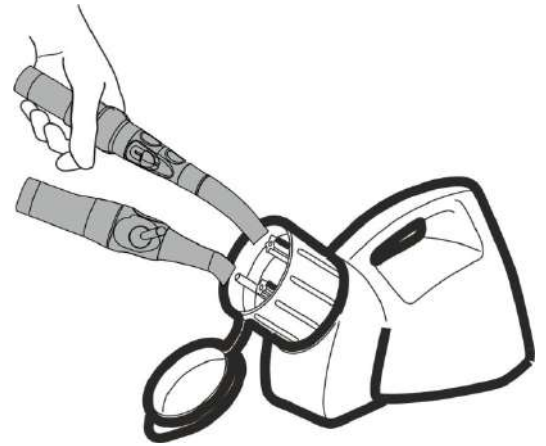
2. Prepare solution of Orotol-Plus by diluting 20 ml of the concentrate in 1 litre of cold water.

Detailed instructions for use of the means "Durr Dental GmbH & Co. KG" are given in the methodical instructions for these products.

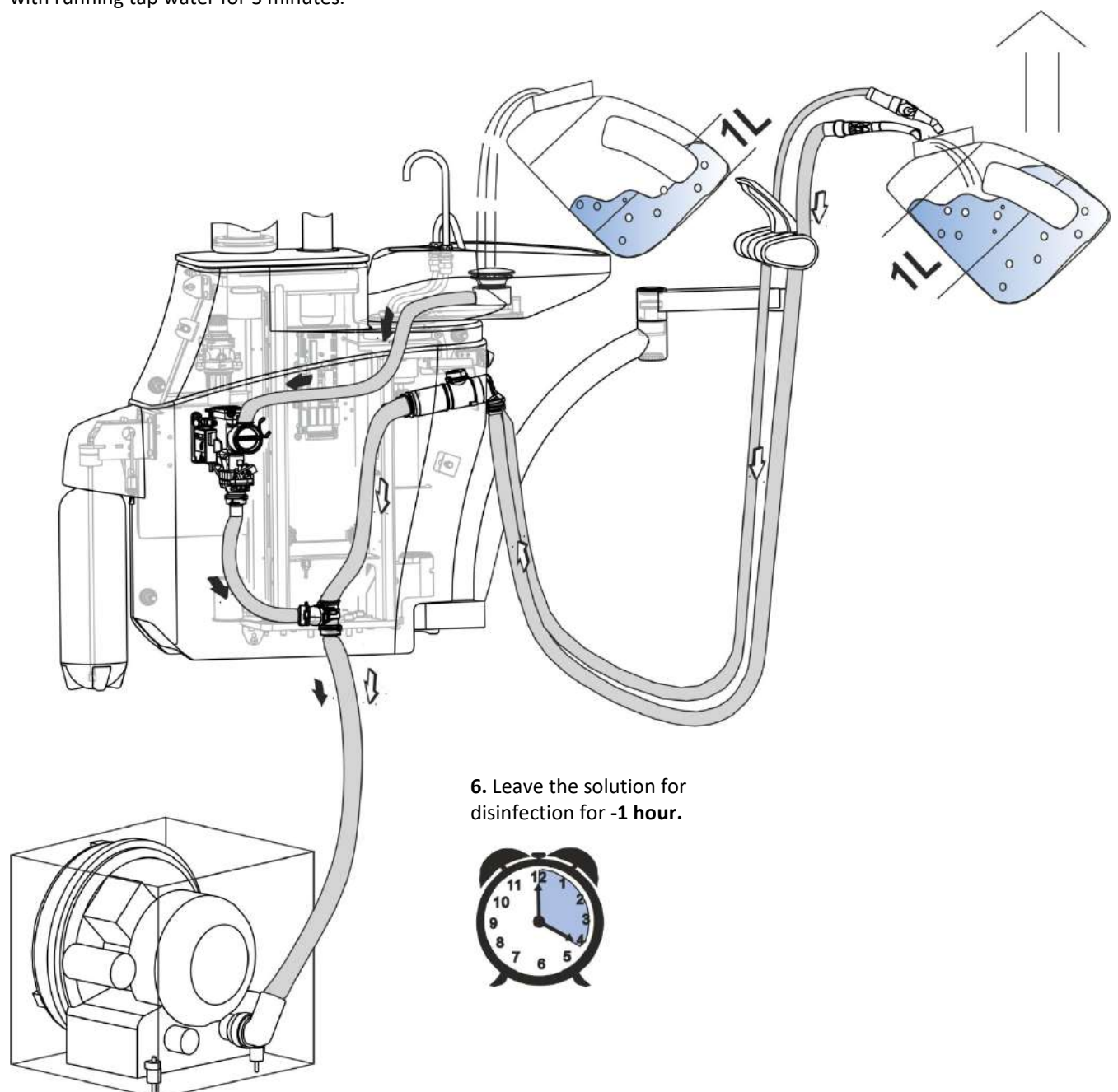


3. Remove the cannulas from the terminals of the handpieces.
Install the handpieces in the "OroCup" container.

4. When using the "OroCup" container of "Durr Dental GmbH & Co. KG" (order code 0780-350-00) the disinfection procedure lasts 4 minutes.

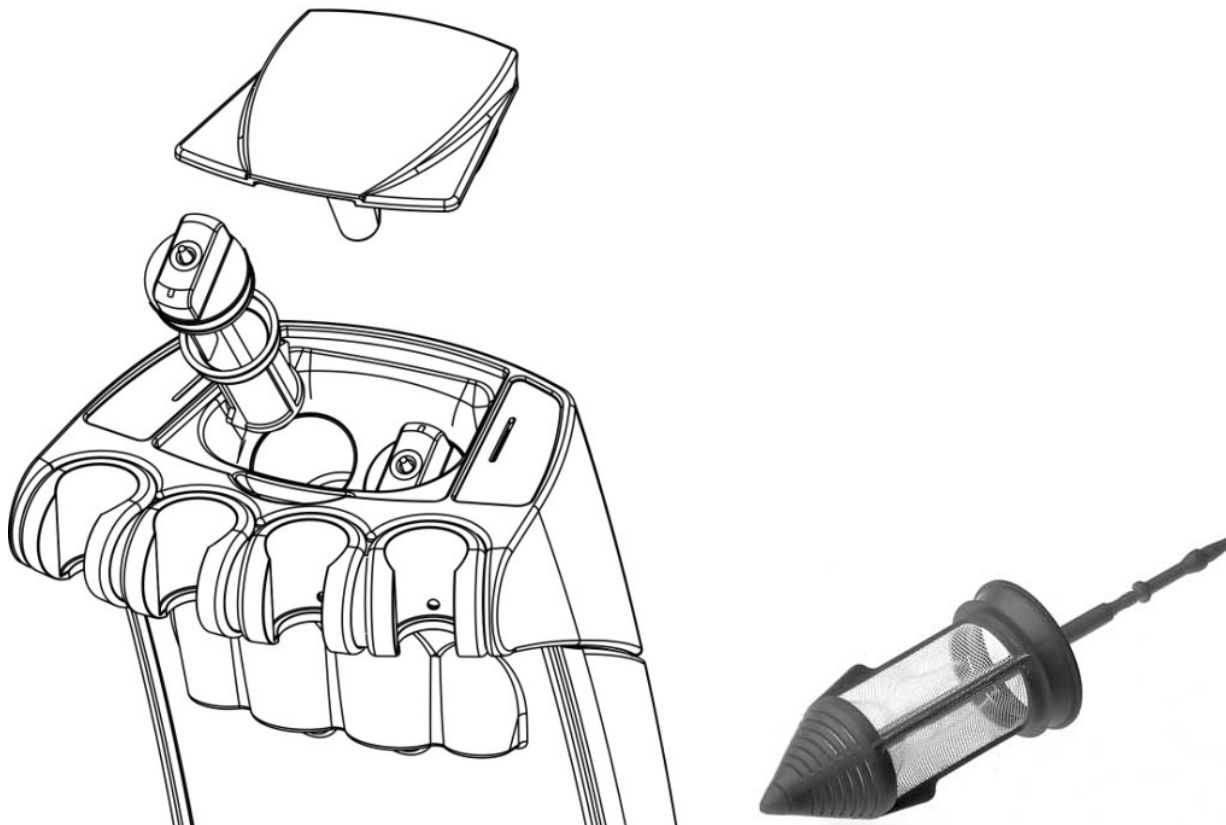


5. Pour the diluted solution of OROTOL into the cuspidor - 1 litre, pass through the cannulas of saliva ejector and dust extractor - 1 litre, fill the separator or valve of the cuspidor with the solution (depending on the unit version). Leave the product to act for 1 hour. Rinse the unit with running tap water for 3 minutes.



7. After the end of disinfection, dry the hoses, for this, remove the handpieces from the holders of the assistant table.

8.8.2 Cleaning the filter of aspiration unit



Once a day is necessary to do the following:

- open the filter cover of the aspiration unit by pulling it towards you;
- pull out the aspiration block filter;
- wash the filter using Durr Dental GmbH & Co. KG" OROTOL-Plus or neutral detergents;
- assemble the filter of the aspiration unit in the reverse order.

ATTENTION The manufacturer guarantees reliable operation of suction dental systems only when using Durr Dental GmbH & Co. KG" OROTOL-Plus.



The use of foaming detergents for cleaning and disinfection of suction dental systems is strictly prohibited.

8.9 Separator

8.9.1 Separator "CS1"

Separator CS1 of company "Durr Dental" is a fully automatic device, non-disassembleable. Flushing and cleaning is carried out during cleaning of the entire aspiration system.



Figure 8.9.2.

VARIO

Vario Durr Dental rinsing device is intended for use in an aspiration system. The device is connected to the water supply system, which allows you to constantly add water to the aspiration system (0.1-0.2 l/min). The constant supply of water prevents any formation of highly soluble plaque and occurrence of blood coagulation in the system.

8.9.2 Maintenance of separator CS1 of the aspiration system with collector of solid particles

1. **Separator CS1** of company "Durr Dental" is a fully automatic device, non-disassembleable. Rinsing and cleaning is carried out during cleaning of the entire aspiration system.

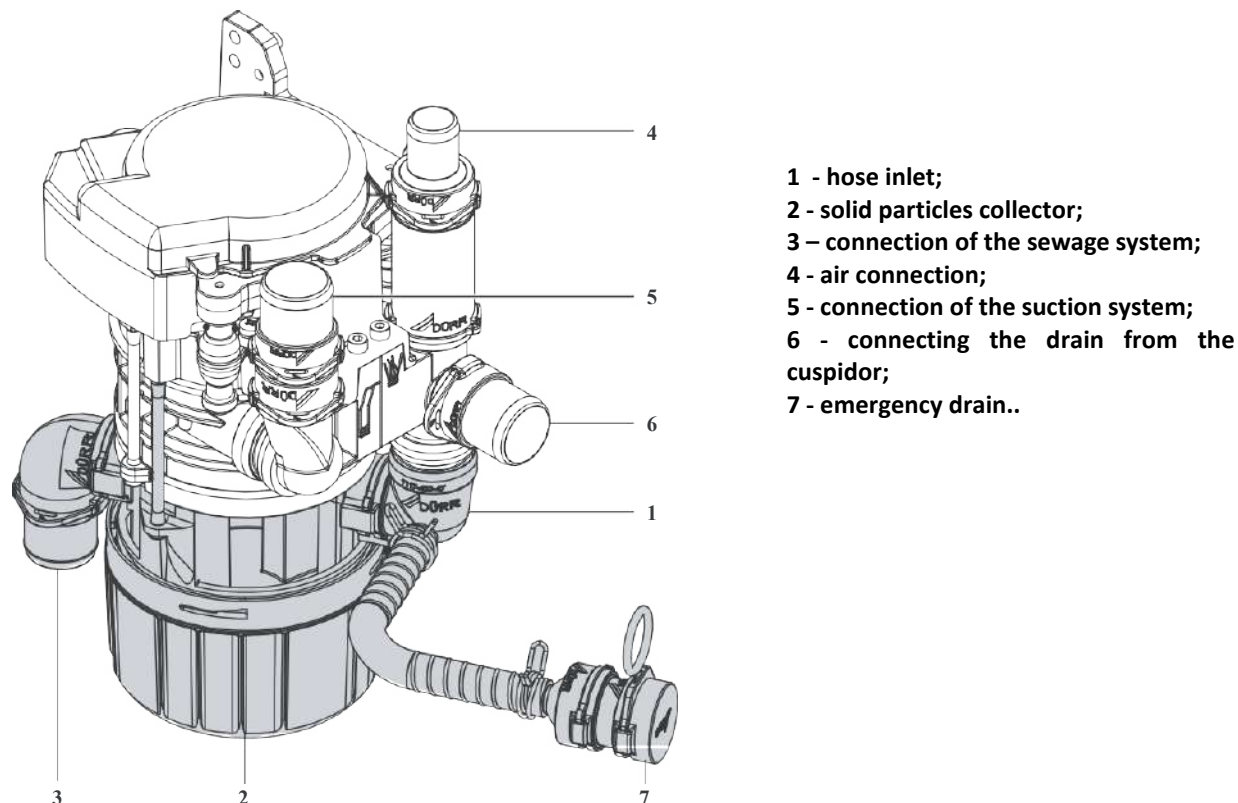


Figure 8.9.1.

2. Maintenance of the solid parts collector.



ATTENTION! It is recommended to use waterproof gloves when replacing the solid parts collector, in order to avoid risk of contamination.

Maintenance consists of checking the solids collector at least once a week, followed by replacement or cleaning of the collector.

When cleaning the solid parts collector, replace the filter with a new one.

Wear of the O-ring in the manifold can lead to leaks, so the O-ring must be replaced when necessary.

Consumables:

Solid particles collector with backing ring, with 5 filter cartridges - order number: 7117-034-00

Backing ring for solid particles collector, with 10 filter cartridges – order number: 7117-035-00

3. Faults.

If the solids collector is not cleaned or replaced in a timely manner, it will overflow, which can cause system blockage. When the collector is full, a noise can be heard in the separator or there will be a return of the flow of liquid to the cuspidor. If this situation occurs, use the emergency drain and then replace the manifold without risk of spillage or overflow.



Detailed instructions for operation and maintenance are given in the operational documentation for the separator.

8.9.3 Separator of “Cattani” company

It is necessary once a week:

- disconnect nozzles with hoses from the cover **1** of the separator;
- disconnect the electrical cable of the separator from A120M water unit board;
- remove separator cover **1** from the separator housing **2**, having previously released the rubber fasteners **3**;
- pull out the separator housing from the holder **5**;
- clean and rinse the cover **1** of separator with electrodes and separator housing;
- make assembly of the separator in reverse order.

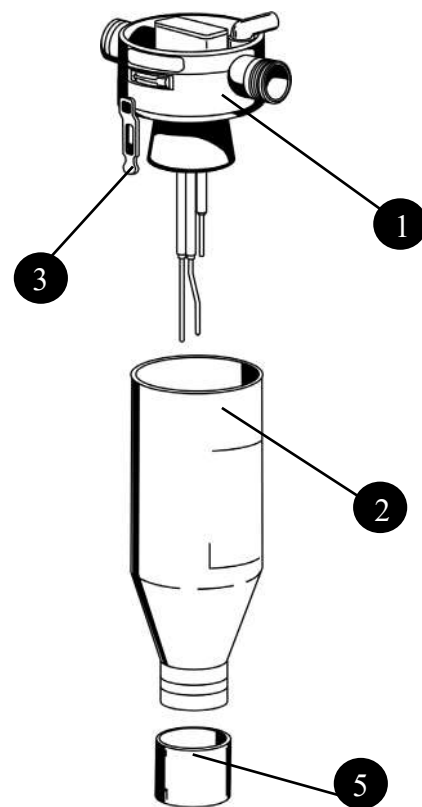
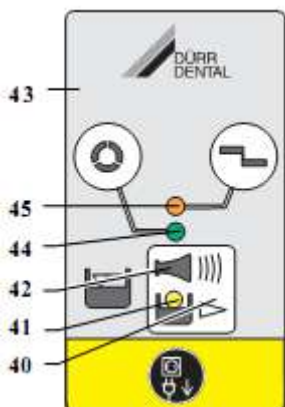


Figure 8.9.3.1.

8.9.4 Separator “CAS1”

8.9.4.1. Indication of Separator CAS1



Procedure of operation

Ready for operation

- GREEN indicator (44) is on

Amalgam container is filled up to 95%


- YELLOW indicator (41) is on
- GREEN indicator (44) is on and beep sounds.

At 95% filling, the sound signal can be switched off with the button (44). At the same time, the GREEN indicator (44) lights up and the separator is ready for further work. The YELLOW indicator is on to remind you to replace the amalgam container. Each time the main switch is switched on, indication of the filling level is repeated.



It is recommended to replace the amalgam container when it is 95% full.

Amalgam container is 100% full

- YELLOW indicator (41) is on
- ORANGE indicator (45) flashes and beeps 


At **100% filling level**, the sound signal can no longer be switched off by pressing the button (40). Replace the container.



In order to avoid infection, it is recommended to use waterproof gloves when changing the amalgam container.

Only after replacing the amalgam container the amalgam separator is “Ready to operation” again.

Container is not installed

- ORANGE indicator (45) flashes and beeps. 

By briefly pressing the button (40), you can switch off the sound signal.

Switch Off (ВІКЛЮЧИТИ) the device.


Insert the container.

Switch On (ВКЛЮЧИТИ) the device.

The green indicator lights up "Ready to operation"

If, after installing the container, the orange indicator continues to light, there is a malfunction of the equipment - **notify the technician for troubleshooting.**

Engine failure

- ORANGE indicator (45)
- GREEN indicator (44) flashes from time to time
- Beep sounds. 

By briefly pressing the button (40), you can switch off the sound signal.

When the button (40) is pressed for more than 2 seconds, the separator can be started again.

The green indicator lights up "Ready to operation".

If after repeatedly pressing the button (40) the signal is still lit, then there is a malfunction - notify the technician.

8.9.4.2. Coarse cleaning filter

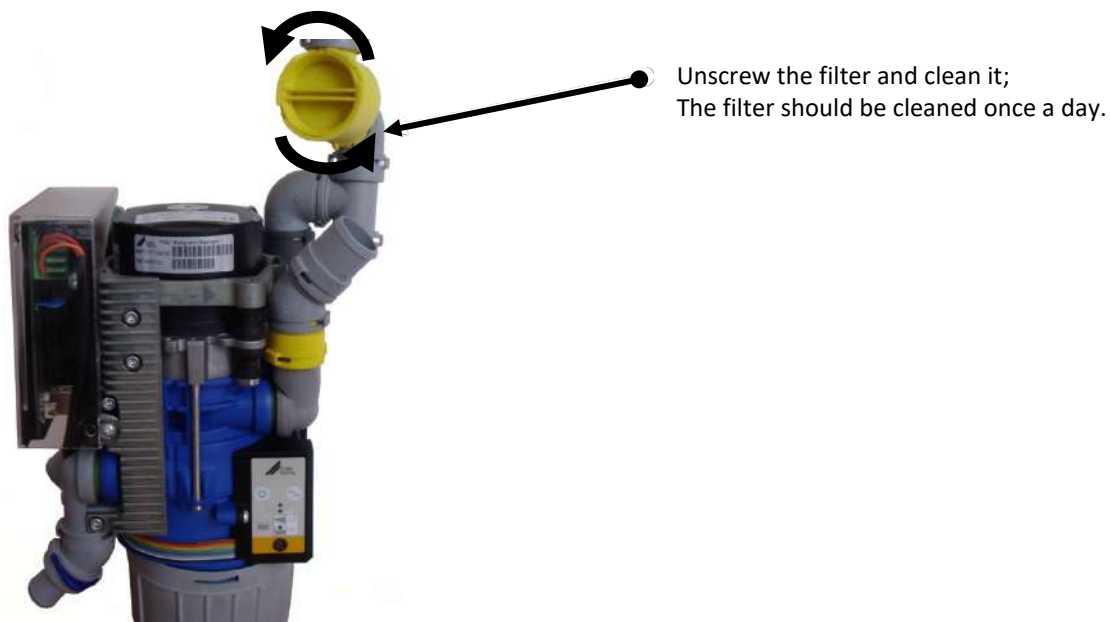


Figure 8.9.4.2.1

8.9.4.3. Maintenance of separator CAS1. Replacing the container for collecting amalgam.

1. Cleaning of filter 0700-700-18.

To do this, you need to remove the fasteners and clean the inlet filter (replace if necessary).

2. Replacing the container for collecting amalgam.

- Switch off the "GALLANT-Console" main switch. (If you unscrew the container with amalgam and do not switch off the unit, the indicator flashes and the sound signal sounds);

- Turn the full container for amalgam over and take it down. Remove the contents of the container and wash with a detergent;

- Put the container in place, screw it tightly to stop. Switch on the main switch, the device is "Ready for operation".

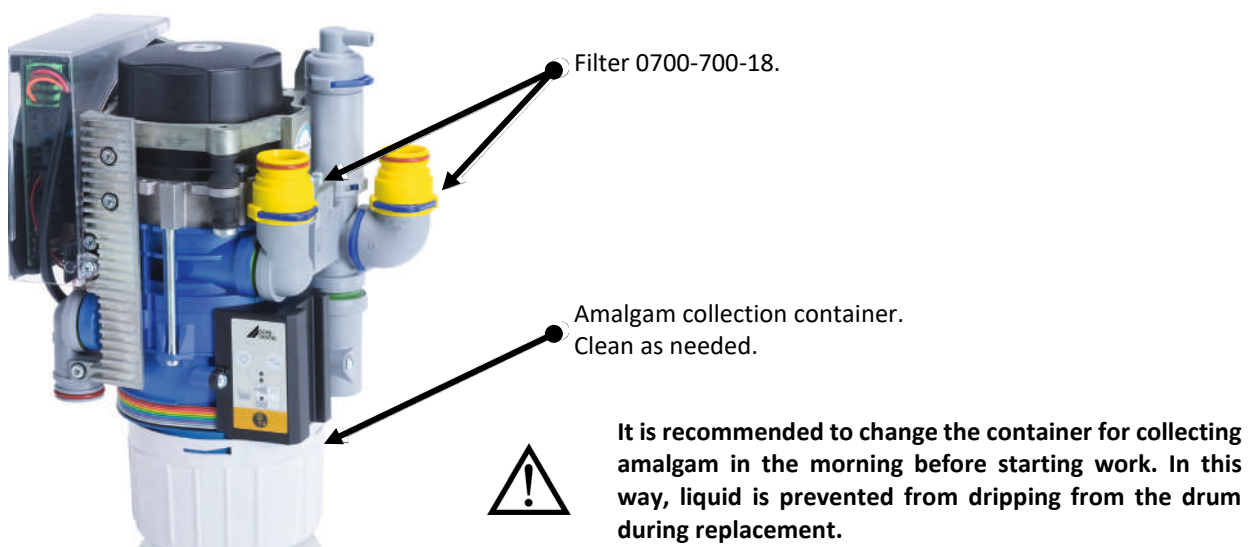


Figure 8.9.4.3.1

8.10 Replacement of fuse links



ATTENTION! Before replacing the fuse links, switch off the unit - for this, switch off the main switch and pull out the plug of the unit power cable from the power outlet ~220V 50Hz.

1. Replacement of the network fuse links placed in the water unit, input block.

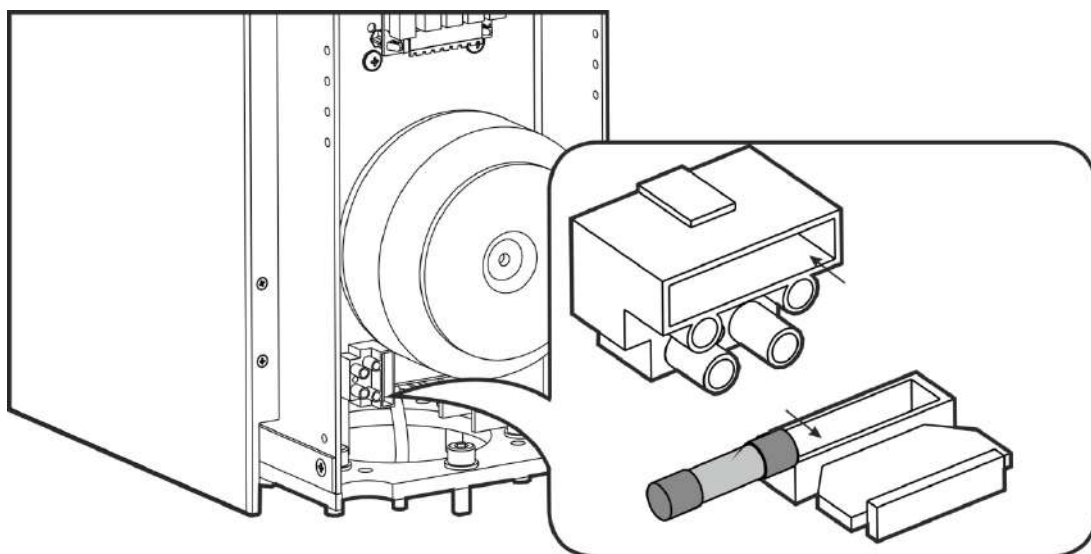


Figure 8.10.1

2. Replacement of fuse links of board A120/6.1.

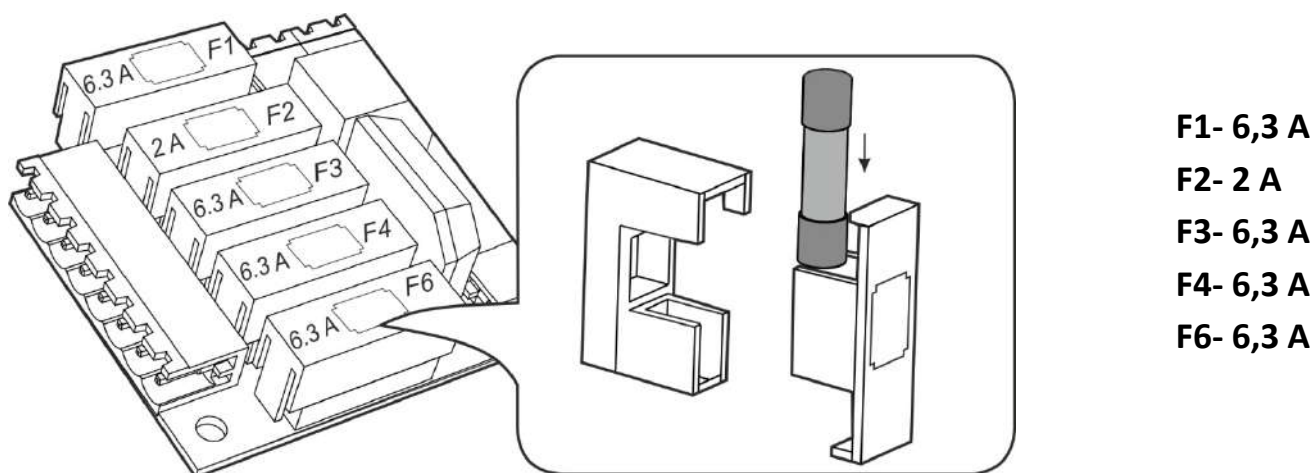


Figure 8.10.2

Designation and technical characteristics of fuse links

Designation	Value	Operating current	Protection	Location in the unit
Fuse link F1	T 6,3 AL	17A / 100mC	Common bus (0V) for the lamp	Water unit. Board A120/6.1
Fuse link F2	T 2 AL	5,4A / 100mC	~18V (powering the valves of the water unit)	Water unit. Board A120/6.1
Fuse link F3	T 6,3 AL	17A / 100mC	~27V (powering the doctor table)	Water unit. Board A120/6.1
Fuse link F4	T 6,3 AL	17A / 100mC	~24V (powering the doctor table)	Water unit. Board A120/6.1
Fuse link F6	T 6,3 AL	17A / 100mC	~24V (for additional devices)	Water unit. Board A120/6.1
Fuse link F1 (X1)	T 4 AL	10,8A / 100mC	Network ~220V	Water unit
Fuse link F2 (X2)	T 4 AL	10,8A / 100mC	Network ~220V	Water unit
Fuse link	2 x T 6,3A	17A / 100mC		At the base of the chair (see the instructions for operating the chair ECO19/STING.)

Appearance and designation of board connectors A120/6.1.

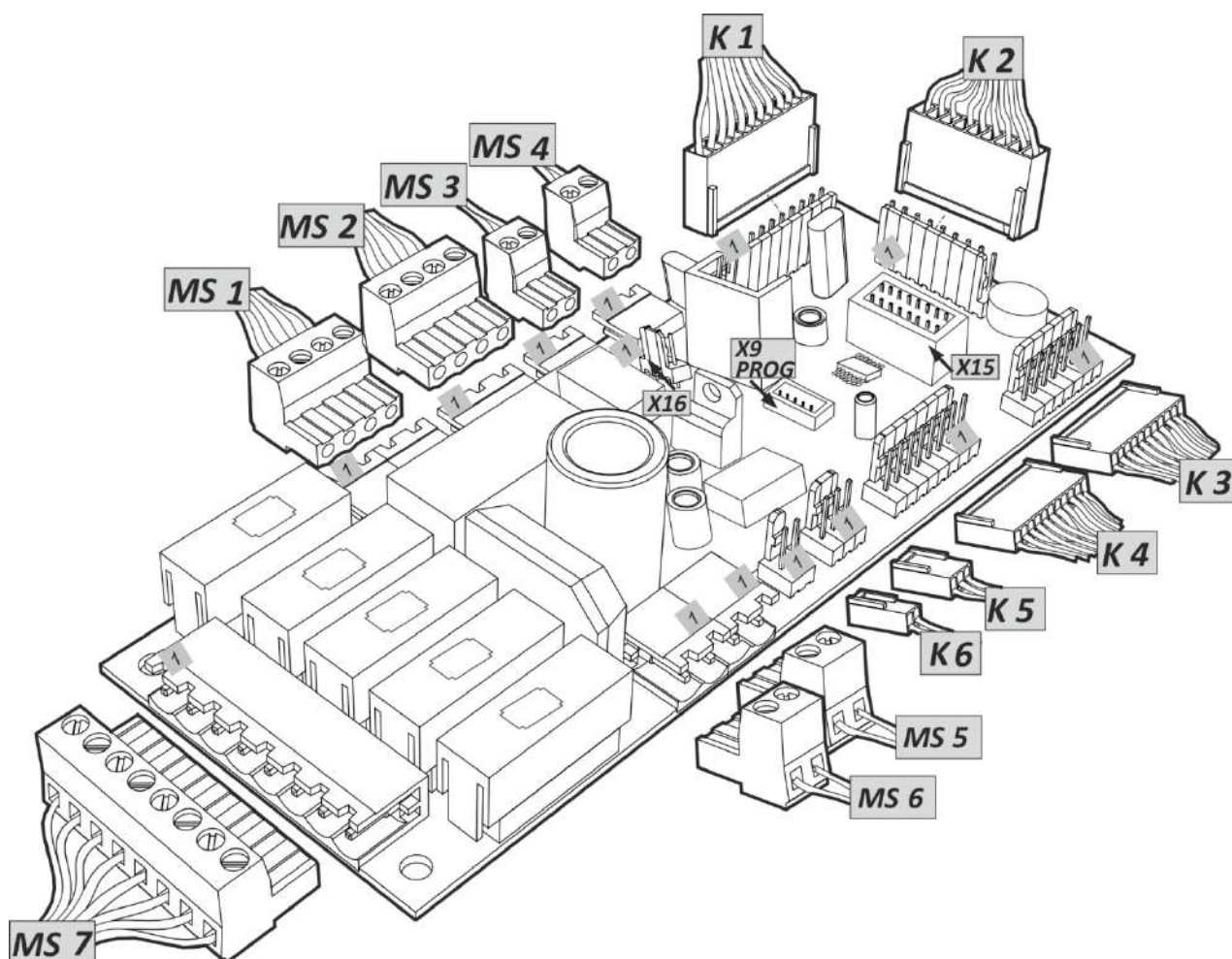


Figure 8.10.3

Functional assignment of contacts for socket connectors MS1-MS7, socket K1-K6, - board A120/6.1.

MS1 (for lamp)		K2 (for foot control)		X9 "PROG"	
1	AC 0V	1	0V (com.)	Connector for programming PIC 16F 886 microcontroller	
2	AC 10V	2	Foot control	X15 (for orthodontic unit)	
3	AC 13V	3	Blowing	1	24V DC
4	AC 18V	4	Spray	2	Proportional valve of the main pneumatic outlet channel
MS2 (for doctor table)		5	Potentiometer (+5V)	3	Pneumatic outlet spray valve
1	AC 24V	6	Potentiometer (ser)	4	Pneumatic outlet blowing valve
2	AC 0V	7	Reverse	5	Micromotor cooling valve
3	AC 27V	8	On	6	Micromotor spray valve
MS3 (for aggregate control)		K3 (solenoid valve of water unit)		7	Micromotor blowing valve
1	Aggregate control AC 24V	1	DC 24V	8	Pneumatic outlet holder
2	Aggregate control AC 24V	2	Valve of saliva ejector	9	Button for illumination of pneumatic outlet
MS4 (for aggregate control)		3	Valve of bowl rinsing	10	Common bus (0V)
1	Aggregate control Short Circuit	4	Valve of cup	11-	Micromotor reverse On/Off
2	Aggregate control Short Circuit	5	Valve of separator rinsing	12	Micromotor reverse On/Off
MS5		6	DC 24V	13-	Pneumatic outlet illumination On/Off
1	AC 24V On/Off	7	Valve of unit selection	14	On/Off
2	AC 24V On/Off	K4 (control from the assistant table)		X16 for powering the proportional valve of the pneumatic outlet in the orthodontic unit	
MS6		1	0V (com.)	1	(7÷21)V DC – smoothly adjustable with a foot control
1	AC 24V	2	Saliva ejector control	2-3	multi-function foot control potentiometer
2	AC 24V	3	Rinsing control		
MS7 (from the power transformer)		4	Cup control		
1	AC 0V	5	Aggregate control		
2	AC 10V	6	Aggregate control		
3	AC 13V	7	Coagulator control		
4	AC 18V	8	Coagulator control		
5	AC 3V	K5 (separator sensors)			
6	AC 3Vcom	1	Sensor 3		
7	AC 24V	2	Sensor 2		
8	AC 24Vcom	3	Sensor 1		
K1 (signals of interaction with the doctor table)		K6 (for coagulator and others)			
1	0V (com.)	1	Control Short Circuit		
2	Foot control	2	Control Short Circuit		
3	Rinsing				
4	Cup				
5	Reverse				
6	Blowing				
7	Spray				
8	Potentiometer (+5V)				
9	Potentiometer (ser.)				
10	Light				
11	Potentiometer (com.)				

8.11 Recommended maintenance frequency

Subassemblies	Periodicity
• Cuspidor bowl filter of the water unit.	after receiving the patient.
• Exhaust air filter of the pneumatic outlet.	Once a month.
• Dust extractor filter CATTANI.	at the end of the work.
• Saliva ejector filter.	at the end of the work.
• Hoses of dust extractor and saliva ejector.	at the end of the work.
• Condensate drain.	at the end of the work.
• Curing lamp (sterilization of the optical fibre, disinfection of external surfaces).	after receiving the patient.
• Turbine handpieces (sterilization, cleaning and lubrication)	after receiving the patient.
• Electric micromotor handpieces (sterilization, cleaning and lubrication).	after receiving the patient.
• Electric micromotor (disinfection of external surfaces).	after receiving the patient.
• Piezoscaler (sterilization or disinfection of external surfaces).	after receiving the patient
• Dental syringe (sterilization or disinfection of external surfaces).	after receiving the patient.
• Cleaning and disinfection of external surfaces of the unit, cleaning of the cuspidor bowl, cleaning of the dental lamp.	at the end of the work.
• Disinfection. Flushing the internal channels of the hoses of the dental unit.	after receiving the patient.
• Cuspidor bowl filter of the water unit.	after receiving the patient.

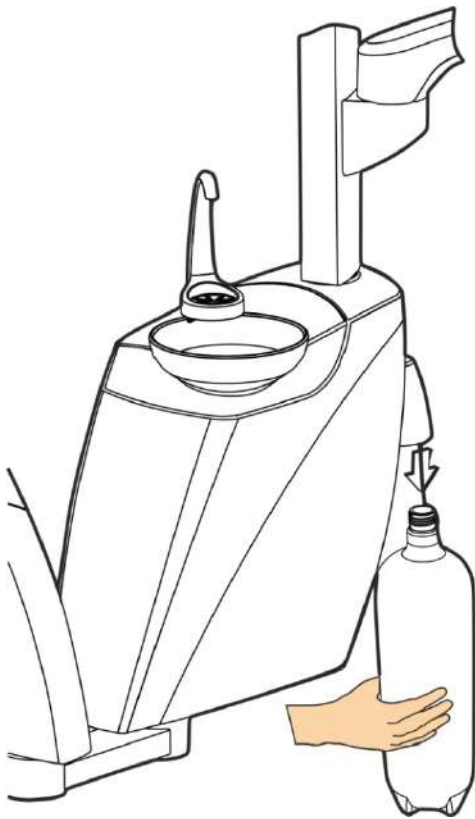
8.12 Technical malfunctions and methods of their elimination



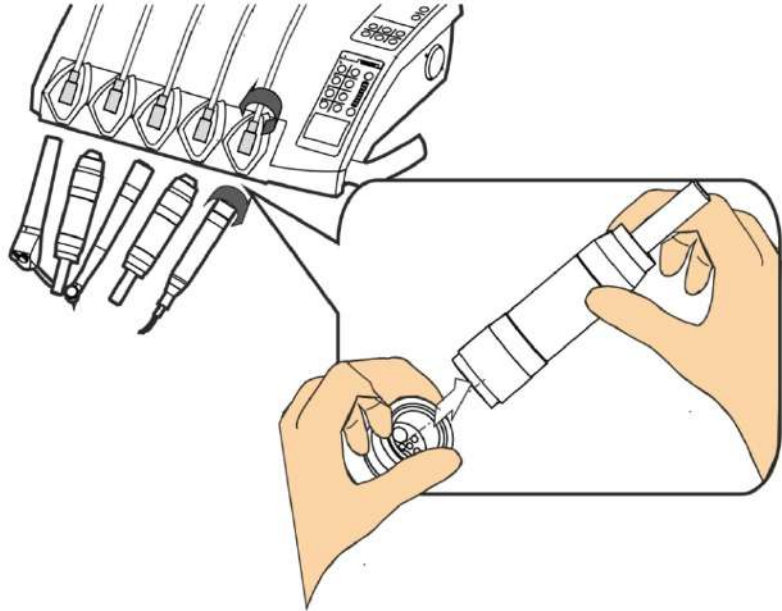
ATTENTION! Before carrying out troubleshooting work, disconnect the unit from the power network: turn off the main switch, turn the handles of the water and air supply taps to the CLOSED position.

Malfunction	Reason	Method of elimination
There is no light indication when the switch is in the on position.	There is no voltage in the power network.	Check presence of voltage in the electrical network.
	Burned fuse links.	Replace the fuse links with serviceable ones from the delivery set.
There is no regulation of the water-air mixture.	Defective water-air mixture adjustment block.	Repair the block.
The lamp does not work when the switch is on.	The lamp bulb has burned out.	Replace the lamp.
The saliva extractor (water) does not work.	Insufficient pressure in the water supply system.	Check pressure in the water supply system.
	Clogged external water filter.	Rinse the external water filter.
Leakage of air or water.	The tightness of the joints is broken.	Eliminate leaks.
There is no water supply through the dental syringe.	Clogged syringe tip channel.	Clean the water supply channel of the handpiece with a mandrel from the turbine handpiece delivery kit.

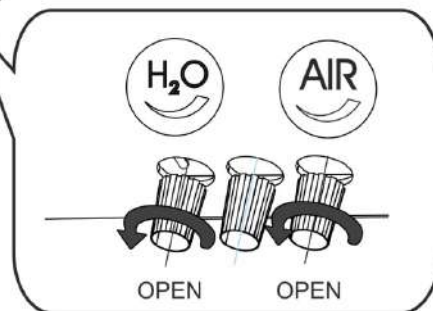
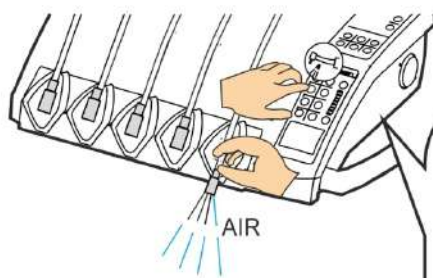
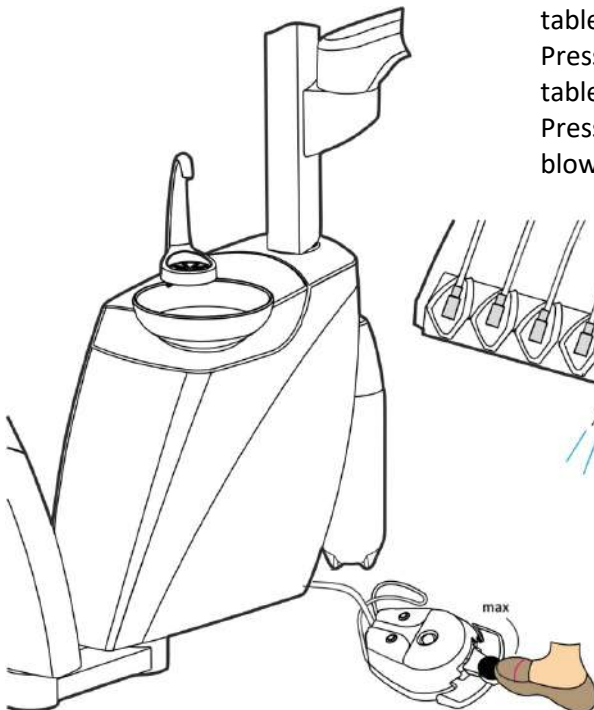
8.13 Disinfection. Flushing the internal channels of the hoses of the dental unit



1. Disconnect the container of the distilled water system DWS. Drain the water. Screw the empty container.
2. Remove the handpieces from the instrument holders.



3. By the regulator located at the bottom of the doctor table unscrew the air supply AIR. Press the SPRAY button on the control panel of the doctor table. Press the foot control so that the water comes out and blow air channels of hoses.

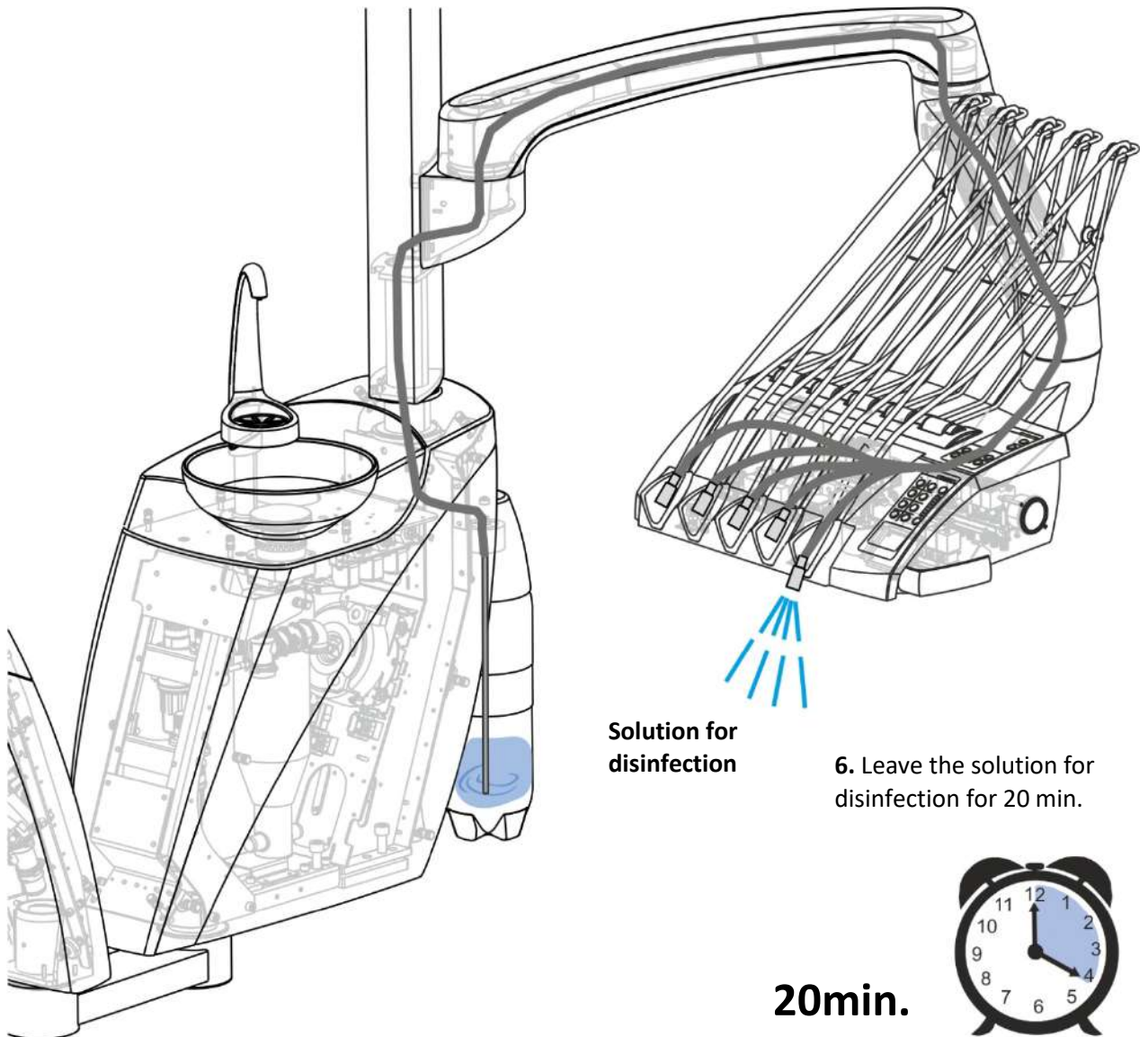


WARNING! The DWS/water pipe switch (if present in the unit) must be in the DWS position during disinfection!



4. In the distilled water system container pour 20 ml of a 3% solution of hydrogen peroxide per 1 litre of the distilled water.

5. Fill all instruments with hydrogen peroxide solution. Press the foot control. Press the button on the control panel of the doctor unit. So that the solution reaches the instruments.



Solution for disinfection

6. Leave the solution for disinfection for 20 min.

20min.



7. Blow out the air channels of the hoses again to clean them from the disinfectant solution according to point 3.



ATTENTION!
month.

Do not leave the hydrogen peroxide solution in the unit for more than 1

9 Electromagnetic Compatibility (EMC) (MEK 60601-1-2)

Important operating characteristics during EMC testing

No	Function check	Normative data
1.	Checking the adjustment of rotation frequency of the instrument with a micromotor, rpm.	The function is being tested "regulated / not regulated"
2.	Checking the adjustment of rotation frequency of the air turbine instrument, rpm.	The function is being tested "regulated / not regulated"
3.	Switching on reverse, spray, negatoscope, lamp	The function is being tested "switches on / does not switch on"
4.	Checking operation of the dental syringe	The function is being tested "switches on / does not switch on"

"Gallant DU/DL" installation locations sensitive to electrostatic discharge are marked with warning symbols and inscriptions:




It is forbidden to touch the contacts of the connections that have a warning symbol on the marking about sensitivity to electrostatic discharge.

Precautions must be taken before connecting to these connections.

Manufacturer's manual and declaration (electromagnetic radiation)			
The dental unit "Gallant DU/DL" is intended for operation in the following electromagnetic environment. The customer or user is obliged to ensure operation under the following environmental conditions.			
	Radiation test	Conformity	Electromagnetic environment (recommendations)
	RF radiation CISPR 11	Group 1	The dental unit "Gallant DU/DL" uses high-frequency energy only for its internal functioning. Therefore, its high-frequency radiation is insignificant and is unlikely to cause any interference in the electrical equipment located nearby. The dental unit "Gallant DU/DL" is intended for use in residential and non-residential premises, as well as in premises connected to the low-voltage power network, which is supplied to the premises for domestic use.
	RF radiation CISPR 11	Class B	
	Harmonic radiation MEK 61000-3-2	Class A	
	Voltage fluctuations/ flicker MEK 61000-3-3	Conforms	

Керівництво і декларація виробника. Електромагнітна завадостійкість			
Dental unit "Gallant DU/DL" is intended for use in the following electromagnetic environment. The user of the dental unit "Gallant DU/DL" is obliged to ensure operation in the same electromagnetic environment.			
Immunity test	Test level MEK 60601	Compatibility level	Electromagnetic environment (recommendations)
Electrostatic discharge (ECP) MEK 61000-4-2	±6 кV, contact discharge ±8 кV, air discharge	±6 кV, contact discharge ±8 кV, air discharge	The floor should be made of wood, concrete or ceramic tiles. If the floor is covered with a synthetic coating, then the relative humidity should be at least 30%.
Short-term impulse disturbances MEK 61000-4-4	±2 кV for the power line ±1 кV for line in/out	±2 кВ for the power line ±1 кV for line in/out	Requirements for the electrical network as a power source are the same as for medical premises.
Impulse disturbances of great energy MEK 61000-4-5	±1 кV between lines ±2 кV between lines and ground	±1 кV between lines ±2 кV between lines and ground	Requirements for the electrical network as a power source are the same as for medical premises.
High-energy impulse disturbances Voltage dips, short-term voltage interruptions and changes in the mains supply voltage MEK 61000-4-11	<5% UT (voltage drop UT >95%) for 0.5 period 40% UT (voltage drop UT 60%) for 5 periods 70% UT (30% UT voltage drop) for 25 periods <5% UT (UT voltage drop >95%) for 5 seconds	<5% UT (voltage drop UT >95%) for 0.5 period 40% UT (voltage drop UT 60%) for 5 periods 70% UT (30% UT voltage drop) for 25 periods <5% UT (UT voltage drop >95%) for 5 seconds	Requirements for the electrical network as a power source are the same as for medical premises. If uninterrupted operation of the " Gallant DU/DL " dental unit is required, in case of interruptions in the power supply network, it is recommended to power the " Gallant DU/DL " dental unit from an uninterruptible power source or batteries.
Magnetic fields with the frequency of the network MEK 61000-4-8	3 A/m	3 A/m	Requirements for the magnetic field of the industrial frequency must correspond to the values established for medical premises.
*Note. U_T – change in network voltage before applying the test level.			

Manufacturer's manual and declaration. Electromagnetic immunity			
Dental unit "Gallant DU/DL" is intended for use in the following electromagnetic environment. The user of the " Gallant DU/DL " unit is obliged to ensure operation in the same electromagnetic environment.			
Immunity test	Test level MEK 60601	Compliance level	Electromagnetic environment (recommendations)
Conductive radio interference MEK 61000-4-6	3 V (root mean square value) 150 kHz to 80 MHz, excluding bands ПНМ ^a	3 V	The distance between the used portable or mobile RF communication equipment and any part of the "GALLANT DU/DL" dental unit, including cables, must be at least the recommended minimum distance, which is calculated from the formula for the corresponding part of the transmitter. Recommended distance: $d = 1,2\sqrt{P}$ $d = 1,2\sqrt{P}$ (from 80 MHz to 800 MHz) $d = 2,3\sqrt{P}$ (from 800 MHz to 2.5 GHz) where P is the maximum output power of the transmitter in watts (W) according to the data of the transmitter manufacturer, and d is the recommended distance of the equipment in meters (m).b The strength of the field created by stationary radio transmitters is determined by electromagnetic research, ^a must be less than the compatibility level in each frequency range. ^b Interference may appear near equipment marked with the following symbol: 
Radiated radio interference MEK 61000-4-3	3 V/m from 80 MHz to 2.5 GHz	3 V/m	
<p>*Note 1. At 80 MHz and 800 MHz, the value for the upper frequency range applies.</p> <p>*Note 2. These recommendations do not apply to all situations. The propagation of electromagnetic waves is affected by absorption and reflection caused by structures, objects and people.</p>			
<p>^a The field strength generated by fixed transmitters, such as radiotelephone (mobile/wireless) base stations, land mobile radio stations, amateur radio stations, AM and FM radio broadcast transmitters, and television broadcast transmitters cannot be theoretically predicted with accuracy. In order to assess the electromagnetic environment affected by fixed radio transmitters, an on-site electromagnetic immunity study should be provided.</p> <p>If the measured values of the field strength at the place of operation of the "GALLANT OMNIPRATIQUE" dental unit exceed the compatibility level indicated above for this case, then the normal functioning of the "GALLANT OMNIPRATIQUE" dental unit should be checked for some time. If there are deviations from normal functioning, additional measures should be taken, for example, changing the placement of the dental unit "Gallant DU/DL".</p> <p>^b In the entire frequency range from 150 kHz to 80 MHz, the field strength must be at least 3 V/m..</p>			

Recommended safe distance between portable and portable radio communication devices and the equipment or system

The dental unit "Gallant DU/DL" " is intended for use in an electromagnetic environment in which radiated radio interference is controlled. The user of the "GALLANT OMNIPRATIQUE" dental unit can ignore electromagnetic interference if he observes the minimum distance between portable and mobile radio communication devices (radio transmitters) and the recommendations below, in accordance with the maximum output power of the radio communication equipment.

Standardized maximum output power of the transmitter, W	Distance depending on the frequency of the transmitter, m		
	From 150 kHz to 80 MHz $d = 1,2\sqrt{P}$	From 80 MHz to 800 MHz $d = 1,2\sqrt{P}$	From 800 MHz to 2.5 GHz $d = 2,3\sqrt{P}$
0,01	0,12	0,12	0,24
0,1	0,37	0,37	0,74
1	1,17	1,17	2,34
10	3,69	3,69	7,38
100	11,67	11,67	23,34

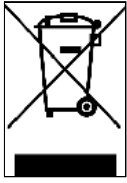
For transmitters whose maximum output power is not listed above, the recommended distance in meters (m) can be calculated using the formula applied to the frequency of the transmitter, where P is the maximum rated output power of the transmitter in watts (W) as specified by the manufacturer of that radio transmitter.

***Note 1.** At 80 MHz and 800 MHz, a higher frequency range is used.

***Note 2.** These recommendations do not apply to all situations. The propagation of electromagnetic waves is affected by their absorption and reflection from premises, objects and people.

10 Disposal

Disposal of dental units



According to directive 2002/96/EC, to prevent environmental pollution and injury during disposal, please follow the disposal laws.

It is possible that the dental unit is infected. Be sure to report this to the company so that appropriate security measures can be taken.

Uncontaminated plastic parts can be sent for plastic renewal.



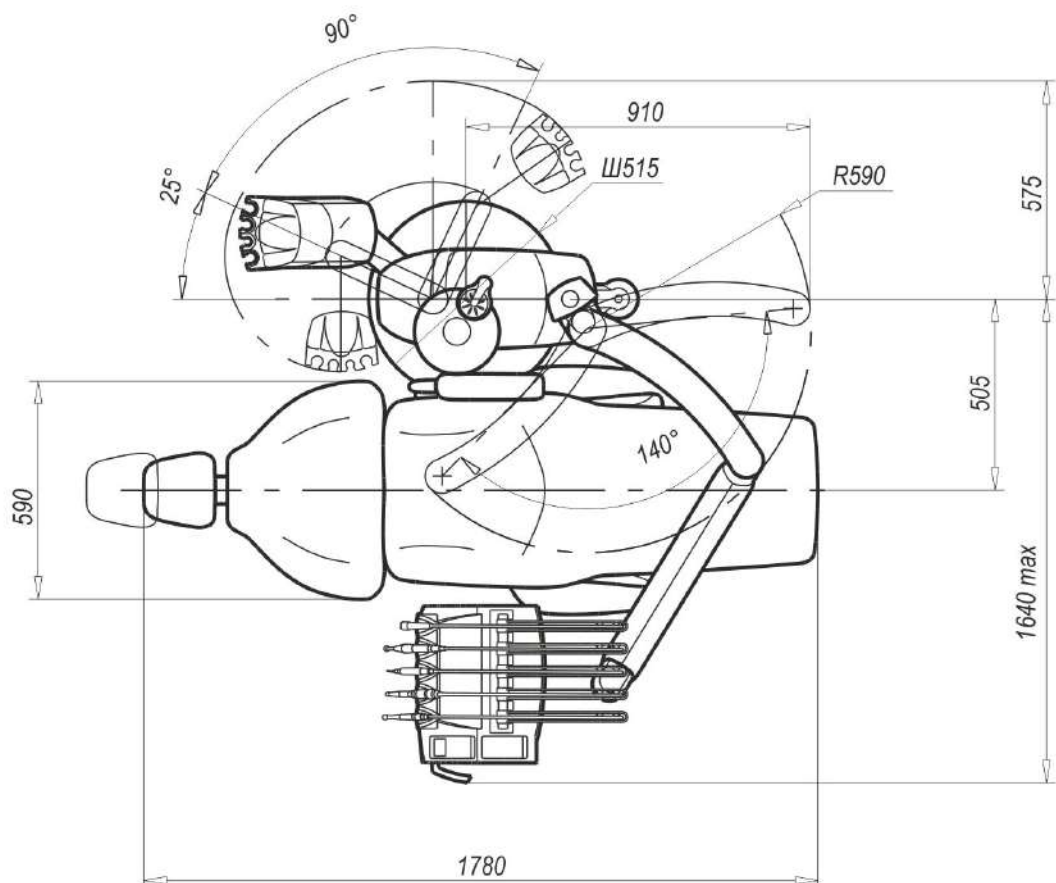
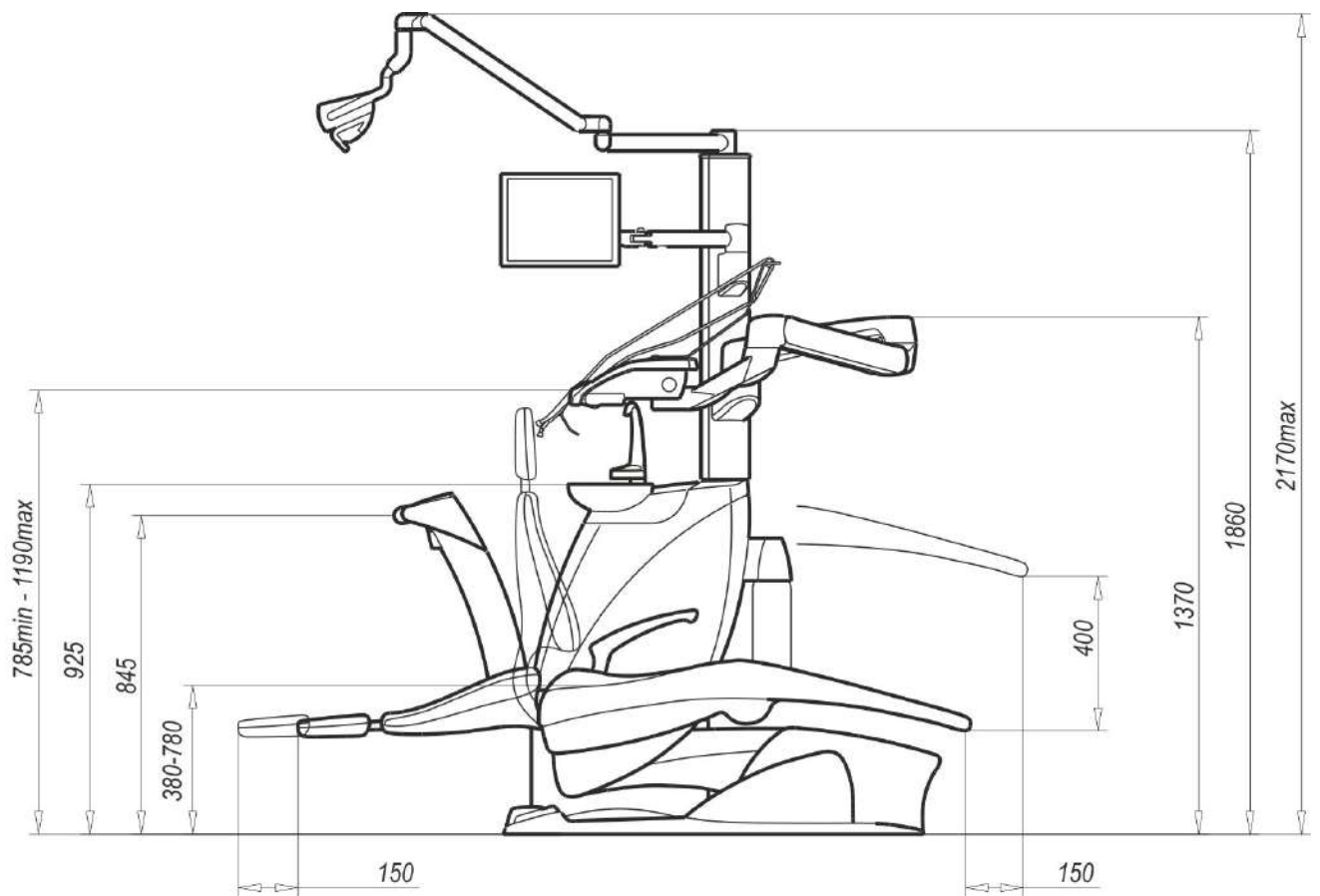
Electronic boards and electronic components must be disposed of as electronic scrap.

Other metal parts (for example, the housing) must be disposed of as scrap metal.

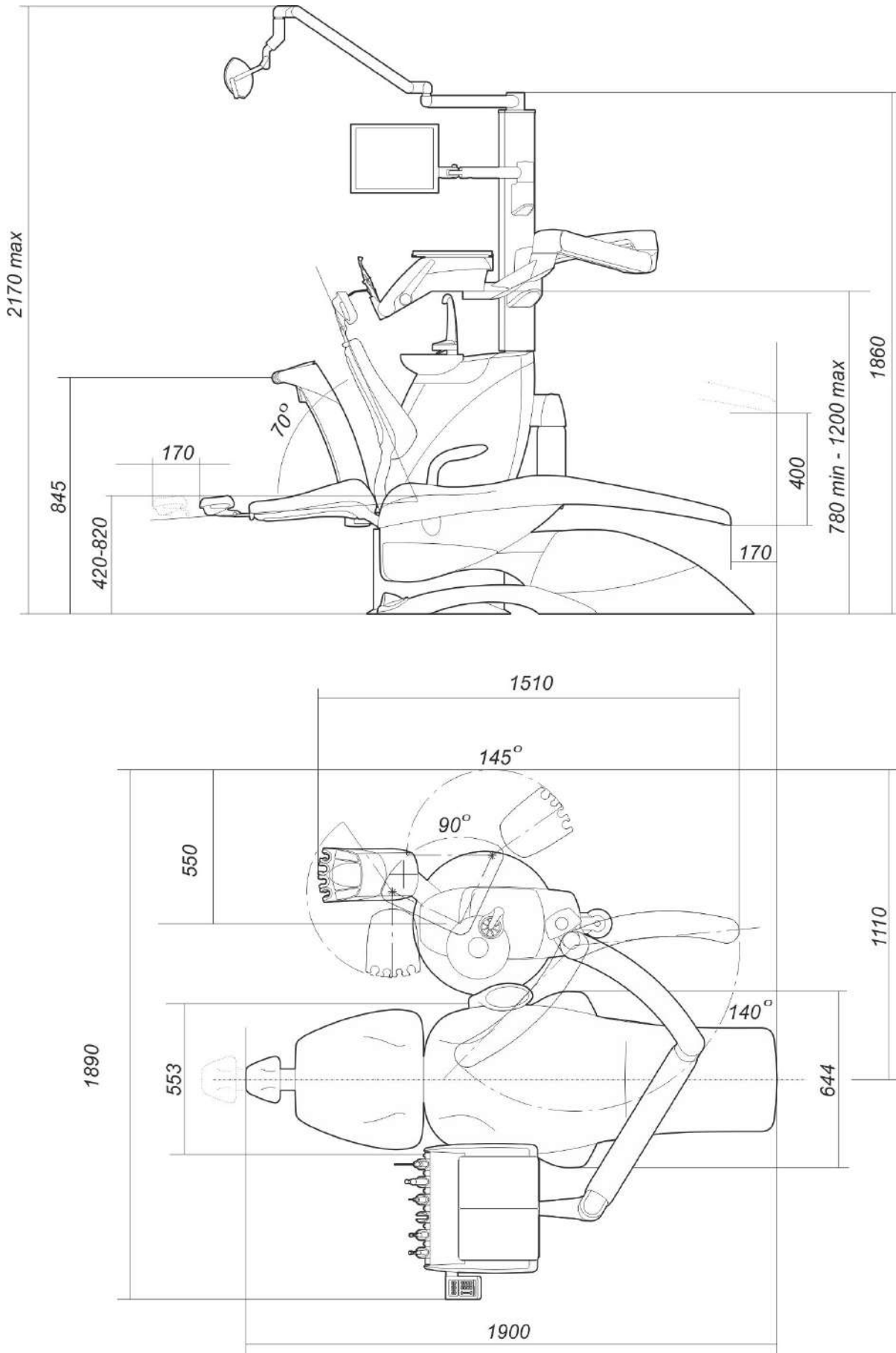
Other components of the dental unit can be disposed of in accordance with the applicable local disposal instructions.

If the dental unit is not completely decommissioned, contact the manufacturer or seller of this dental unit.

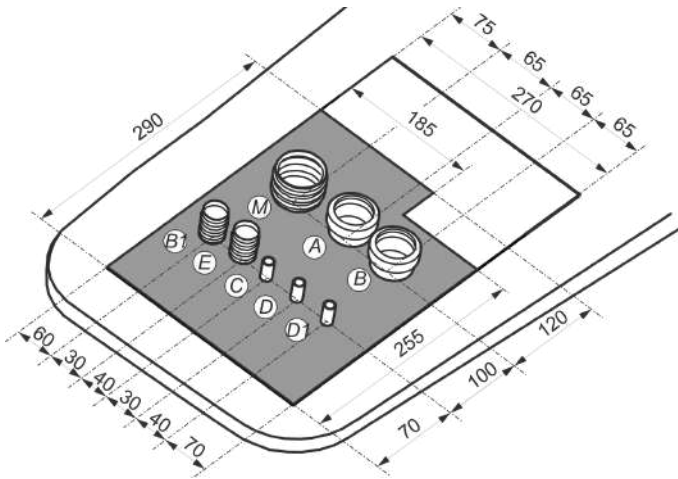
Appendix A1. Overall dimensions of dental unit "Gallant DU".



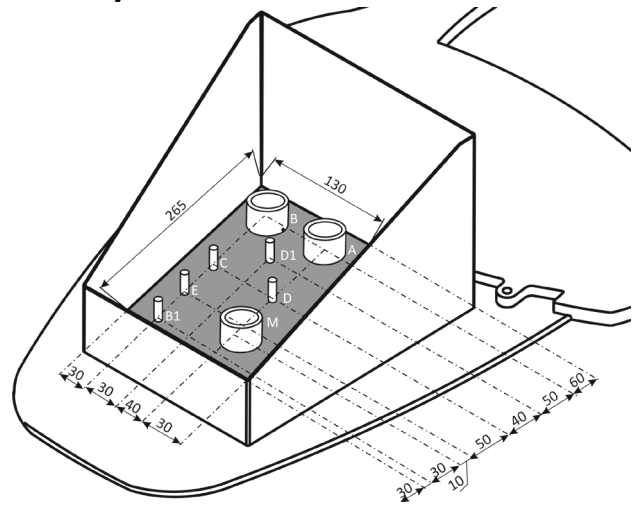
Appendix A2. Overall dimensions of dental unit "Gallant DL".



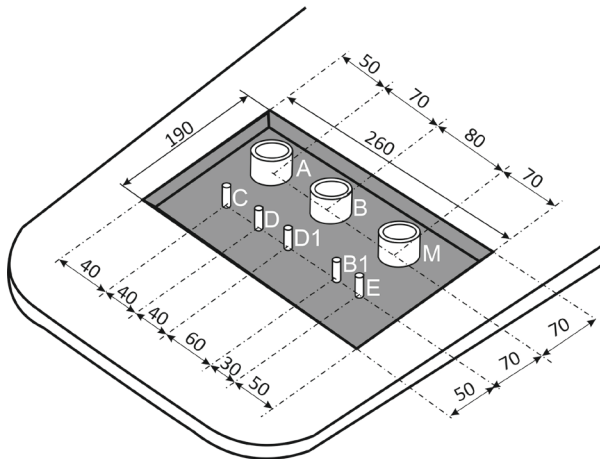
Appendix B. Recommended plan for supply of service lines for dental unit "GALLANT DU/DL".



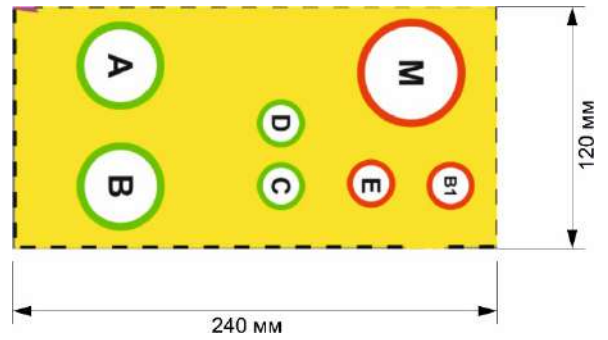
with chair ECO NEXT



with chair STING



with chair ECO 19



with chair 2009 NEXT

A	Connection to the sewage system	Plastic pipe $\varnothing=50$ mm (internal) (DIN 50), height at floor level or maximum (30÷50) mm.
B	Connection to the exhaust unit	Reinforced hose or plastic pipe $\varnothing=40$ mm (internal) (DN40), height at floor level or maximum (30÷50) mm, slope at least 2%. At the place of installation of the aggregate, provide a channel for exhaust air. For detailed recommendations on the design of the suction system, see "Design Guide" 61703-1206_ru. firm DURR DENTAL.
B1	Control cable of the exhaust unit	Copper cable 2 x 1 mm ² to the place of installation of the aggregate, pulled through a corrugated sleeve: the length of the free ends is 500-1000 mm.
C	Air supply	Copper or plastic pipe, faucet with ½ inch internal thread as close to floor level as possible. The minimum pressure is 8 bar. It is possible to place the faucet in another place, while finishing the line with a ½ inch internal thread .
D	Water supply	Copper or plastic pipe, faucet with ½ inch internal thread as close to floor level as possible. It is possible to place the faucet in another place, while finishing the line with a ½ inch internal thread .
D1	Water supply is a centralized system of clean water of the Distilled Water System (if necessary)	Copper or plastic pipe, faucet with ½ inch internal thread as close to floor level as possible. It is possible to place the faucet in another place, while finishing the line with a ½ inch internal thread .
E	Connection to the power supply network	Network requirements: 220÷230/~50Hz, 900VA copper cable, 3x1.5mm ² circuit breaker 10A. Be sure to ground the network cable. The length of the free ends is 500 mm. It is recommended to install a device for protective disconnection from the network (difrel), for example, 5SM 1312 from the company "Siemens".
M	Multimedia (if necessary)	Plastic pipe or cable channel $\varnothing=50$ mm (internal) (DIN50), with a smooth internal surface to the place of installation of the computer, which is laid with minimal bends. Bending more than 45° is not allowed. Free routing of the VGA cable together with the connector should be ensured.

The leads location sequence is not of importance. Do not place leads close to each other, it is necessary to take into account execution of their connections during installation. If the installer attempts to change the dimensions (diameters), consultation with the supplier is necessary, as this may lead to incorrect operation of the equipment.

Appendix B. Checking parameters of dental equipment

product	Dental unit "GALLANT DU/DL"
Serial number	
date	

In the interests of personnel safety and the proper functioning of the equipment, it is necessary to conduct an electrical safety inspection of the dental unit every year in accordance with the IEC 60601-1-1 standard

It is the owner's responsibility to organize this inspection, as well as to ensure that the technicians who carry out the inspection of electrical safety equipment are highly qualified specialists.

Table 1

No	Electrical safety parameter	Standard item IEC 60601-1-1	Normative index	Available Index (Filled in by a representative of the QD)	Available Index (Filled in by the person responsible for installing the dental unit)
1.	Checking the protective grounding, Ohm	i. 8.6	< 0,2		
2.	Checking the leakage current to the ground, μA	i. 8.7.4.5	< 500		
3.	Checking the leakage current to patient, μA	i. 8.7.4.7	< 100		

Representative of Quality Department _____ (_____)

Person responsible for installing the dental unit _____ (_____)

For your convenience, the form of the electrical safety equipment inspection report is provided below:

after 1 year

Check date	No	Electrical safety parameter	Normative index	Available index	Signature
	1	Checking the protective grounding, Ohm	< 0,2		
	2	Checking the leakage current to ground, μA	< 500		
	3	Checking the leakage current to patient, μA	< 100		

after 2 years

Check date	No	Electrical safety parameter	Normative index	Available index	Signature
	1	Checking the protective grounding, Ohm	< 0,2		
	2	Checking the leakage current to ground, μA	< 500		
	3	Checking the leakage current to patient, μA	< 100		

after 3 years

Check date	No	Electrical safety parameter	Normative index	Available index	Signature
	1	Checking the protective grounding, Ohm	< 0,2		
	2	Checking the leakage current to ground, μA	< 500		
	3	Checking the leakage current to patient, μA	< 100		

after 4 years

Check date	No	Electrical safety parameter	Normative index	Available index	Signature
	1	Checking the protective grounding, Ohm	< 0,2		
	2	Checking the leakage current to ground, μA	< 500		
	3	Checking the leakage current to patient, μA	< 100		

after 5 years

Check date	№	Electrical safety parameter	Normative index	Available index	Signature
	1	Checking the protective grounding, Ohm	< 0,2		
	2	Checking the leakage current to ground, μA	< 500		
	3	Checking the leakage current to patient, μA	< 100		

after 6 years

Check date	№	Electrical safety parameter	Normative index	Available index	Signature
	1	Checking the protective grounding, Ohm	< 0,2		
	2	Checking the leakage current to ground, μA	< 500		
	3	Checking the leakage current to patient, μA	< 100		

after 7 years

Check date	№	Electrical safety parameter	Normative index	Available index	Signature
	1	Checking the protective grounding, Ohm	< 0,2		
	2	Checking the leakage current to ground, μA	< 500		
	3	Checking the leakage current to patient, μA	< 100		

after 8 years

Check date	№	Electrical safety parameter	Normative index	Available index	Signature
	1	Checking the protective grounding, Ohm	< 0,2		
	2	Checking the leakage current to ground, μA	< 500		
	3	Checking the leakage current to patient, μA	< 100		

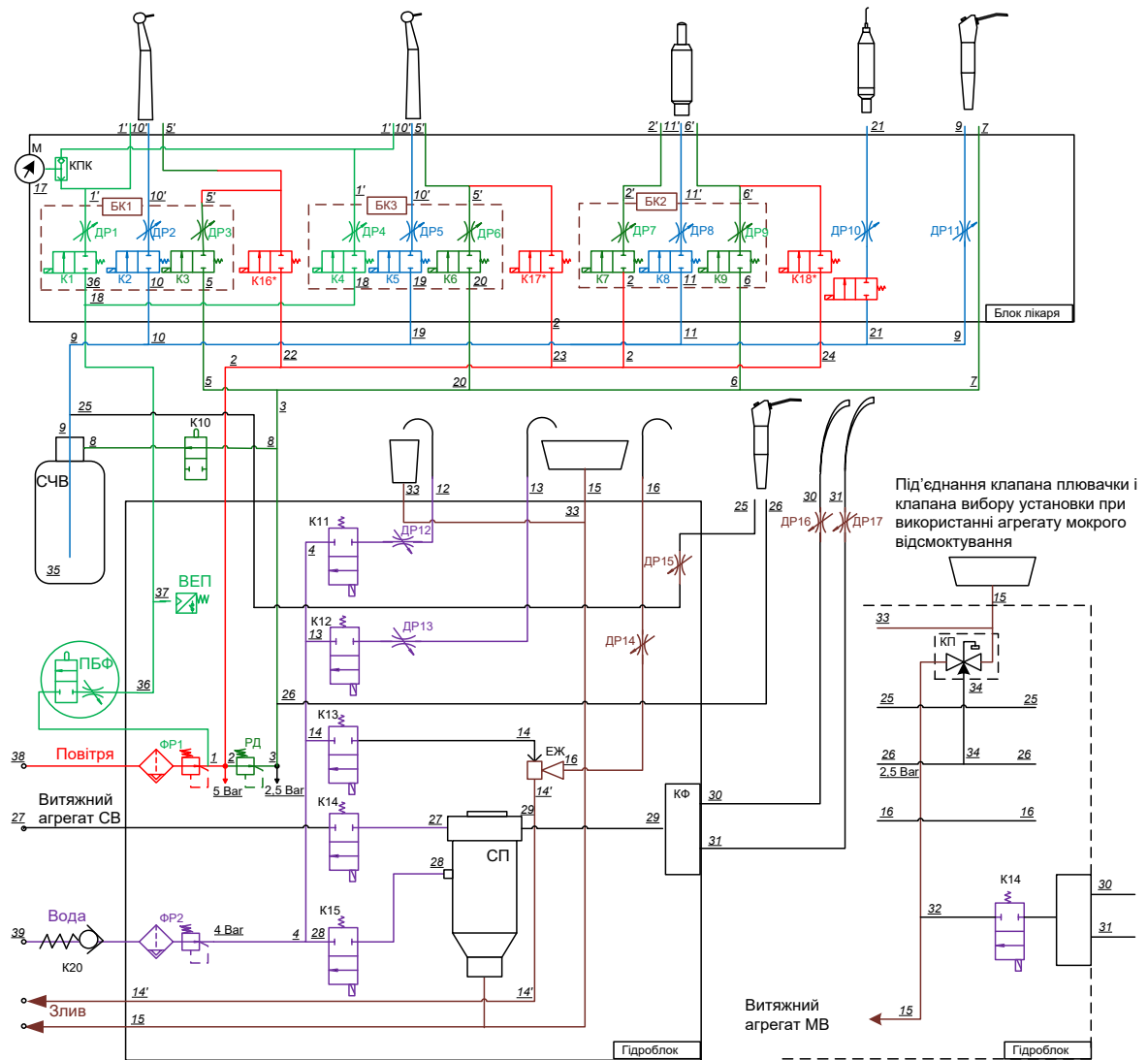
after 9 years

Check date	№	Electrical safety parameter	Normative index	Available index	Signature
	1	Checking the protective grounding, Ohm	< 0,2		
	2	Checking the leakage current to ground, μA	< 500		
	3	Checking the leakage current to patient, μA	< 100		

after 10 years

Check date	№	Electrical safety parameter	Normative index	Available index	Signature
	1	Checking the protective grounding, Ohm	< 0,2		
	2	Checking the leakage current to ground, μA	< 500		
	3	Checking the leakage current to patient, μA	< 100		

Appendix Г. Dental unit “GALLANT OMNIPRATIQUE”. Pneumatic diagram (with additional options).



Dental unit “GALLANT OMNIPRATIQUE”. Pneumatic diagram (with additional options). Designations.

Design.	Name	Code	Supplier
	Air		
	Suction aggregate of dry suction BA-CB		
	Suction aggregate pf wet suction BA-MB		
	Water		
	Drain		
	Water unit		
	Doctor table		
ПП	Pneumatic foot control	FCF-251-03	US. MEDLINK
ПБФ	Multifunctional foot control	P2L1	FARO
ФР1	Adjusting filter	N108-D00	CAMOZZI
ФР2	Adjusting filter	N108-D01-C01	CAMOZZI
РД	Reducer	M008-R00	CAMOZZI
ВЕР	Electropneumatic switch		FARO
СВЧ	Distilled Water System container	P-1811/T	G.COMM S.r.e
СП	Separator	029973	CATTANI
БК1	Block of valves	01-211P204-HO	US. MEDLINK
БК2	Block of valves	01-211P204-HO	US. MEDLINK
БК3	Block of valves	01-211P204-HO	US. MEDLINK

K1	Valve of the main channel of the 1- st pneumatic outlet		
K2	Instrument cooling water valve of the 1st pneumatic outlet		
K3	Instrument cooling air valve of the 1st pneumatic outlet		
K4	Valve of main channel of the 2nd pneumatic outlet		
K5	Instrument cooling water valve of the 2nd pneumatic outlet		
K6	Instrument cooling air valve of the 2nd pneumatic outlet		
K7	El. Micromotor cooling valve		
K8	Water valve (spray) of el. Micromotor handpiece		
K9	Air valve (spray) of el. Micromotor handpiece		
K10	Air switch to Distilled Water System	VAF-451-01	US. MEDLINK
K11	Cup filling valve	RPE2105NC24	R.P.E. S.r.e.
K12	Bowl filling valve	RPE2105NC24	R.P.E. S.r.e.
K13	Water suction valve	V165B01	Sirai
K14	Unit selections valve	7560-500-60	DURR
K15	Separator flushing valve	RPE210SNC24	R.P.E. S.r.e.
K16	Blowing valve (CHIP)	V165B01	Sirai
K17	Blowing valve (CHIP)	V165B01	Sirai
K18	Blowing valve (CHIP)	V165B01	Sirai
K20	Return valve	VNR-210-1/8	Camozzi
КПК	Reversible valve SHUTTLE	VAF-474-01	US. MEDLINK
КП	Cuspidor valve	7560-500-52	DURR
ДР1	Flow regulator		
ДР2	Flow regulator		
ДР3	Flow regulator		
ДР4	Flow regulator		
ДР5	Flow regulator		
ДР6	Flow regulator		
ДР7	Flow regulator		
ДР8	Flow regulator		
ДР9	Flow regulator		
ДР10	Flow regulator of scaler		
ДР11	Water flow regulator of scaler		
ДР12	Water flow regulator		
ДР13	Water flow regulator		
ДР14	Flow regulators of saliva ejector		
ДР15	Water flow regulator of syringe		
ДР16	Flow regulators of saliva ejector		
ДР17	Flow regulators of saliva ejector		
ЕЖ	Ejector		
М	Manometer	M043-R06	CAMOZZI
КФ	Housing with filter	0725-040-00	DURR

11. General warranty terms and conditions

1. PC "GALIT" provides a guarantee for products of its own production and products of other manufacturers, sold by the company, within 12 months from the date of sale, unless other terms are specified in the accompanying documentation for the products.

2. Warranty services are performed by free repair or replacement of a defective part (subassembly).

Cost of arrival of a service employee (or a technical specialist of a sales representative) to fulfil warranty obligations is a paid service according to the approved rates of the Service Center of PC "GALIT". Decision on the method of repair is made by the service department of PC "GALIT", provided that the defects are caused by poor-quality assembly, or poor-quality materials and components within no more than 10 working days from the receipt of the malfunction registration sheet. The term can be extended up to 30 working days if the malfunction requires sending the product for repair or analysis of the occurrence of the malfunction to a foreign company of the manufacturer.

3. A necessary condition for provision of warranty services is presence of the following documents:

- 1) this duly completed Warranty card, which must be kept;
- 2) a completed and registered Tear-off coupon, which must be sent to the manufacturer;
- 3) a completed and certified Record of Warranty Repair, which must be sent during the repair;

4. Acceptance of equipment for performance of warranty services is carried out by GALIT company at the address:

PC GALIT, 6 E, 15 Kvitnya str., v. Baikivtsi, Ternopil region, 47711, Ukraine.

5. The buyer, on his own or through regional representatives of PC GALIT, at his own expense, ensures delivery of defective parts (assemblies) with the Failure Registration Sheet to the above address. Defective parts (assemblies) delivered to PC GALIT must be disinfected and sterilized (for products subject to autoclaving). Defective parts (assemblies) must have original packaging that guarantees safe delivery to the Service Centre.

6. The decision whether a defective component is covered by the warranty is up to PC Galit.

7. Performance of warranty services for overall equipment at the place of installation is provided by regional representatives of the service department of PC GALIT, or technical specialists of sales representatives through whom the equipment was purchased. The condition for the technician's visit to the place of installation of the equipment is a properly filled out and certified malfunction registration sheet and sent to the address of the regional representative of PC "Galit".

8. The warranty does not apply to:

- products with damaged control seals that prevent unauthorized intervention,
- products damaged during transportation or storage;
- products in which arbitrary intervention or arbitrary modifications have been carried out;
- products with defects caused by violation of operating instructions;
- products, in case of non-fulfilment of the requirements for care and maintenance according to the operating instructions (including the materials used and the periodicity of routine work), or other accompanying documents;
- defects in the operation of products and defects caused by non-compliance with the requirements of accompanying documents regarding networks of compressed air, drainage (sewage), electricity and water supply;
- parts and assemblies, the defects of which are caused by natural wear, mechanical damage or the action of chemicals not provided for in the accompanying documents, during operation;
- light bulbs, micromotors, tips, turbines and other tools.
- bulbs of shadowless and surgical lamps.
- all types of electric fuse links.
- nozzles of pneumatic and ultrasonic scalers.
- LEDs of photopolymerization lamps and lights.

9. The warranty conditions do not provide for periodic maintenance and routine work, which the user of the equipment must perform independently in accordance with the operating instructions for the products

10. In the case of an unjustified request for warranty service, the Buyer is obliged to compensate for all expenses of PC "Galit" (or a sales representative) related to the arrival of a technician, according to the approved prices of the Service Centre. In the event of the Buyer's refusal of compensation, the warranty for this product is removed. The decision on the validity of the appeal is taken by PC "Galit" (or its sales representative).

LOG BOOK of accounting for warranty repair (maintenance)

The number under which the product is registered under warranty	Registration date	Full name, address, phone number of the consumer	Product name and factory number. Factory number of the component product, component part	Nature of the shortcomings	Remarks of the performer during the acceptance of the goods for repair	Repair deadline	Date and signature of the consumer on receipt of the goods after repair

The number under which the product is registered under warranty	Registration date	Full name, address, phone number of the consumer	Product name and factory number. Factory number of the component product, component part	Nature of the shortcomings	Remarks of the performer during the acceptance of the goods for repair	Repair deadline	Date and signature of the consumer on receipt of the goods after repair

COUPON for putting into operation within 12 months of the warranty period of operation

Valid after filling

COUPON for putting the GALLANT DU/DL dental unit into operation must be sent to the address of the company "Galit" within 10 days from the moment of installation.

=====

Regional Representative	
Dental Unit User	
Dental Unit GALLANT DU/DL	
Model	
Factory №	
Date of Manufacture	
Date of putting the dental unit into operation	
Address of the Dental Unit location:	
Postal code of the city	
City	
Street	
Building	
Apartment (Office)	
Signature and full name of the person or service department that installed and connected the dental unit	
Contact telephone	
Signature and full name of the unit owner to confirm the commissioning of the dental unit	
Contact Telephone №	

 COUPON for putting into operation GALLANT DU/DL DENTAL UNIT
 (reverse side)

Composition of the dental unit

NAME OF COMPONENT	FACTORY NUMBER
Foot control	
Lamp	
Micromotor	
Micromotor	
Micromotor	
Syringe	
Curing lamp	
Coagulator	
Scaler	
Separator	
Water unit heater	
Doctor table heater	
Monitor	
Camera	
Cuspidor valve	

The person responsible for packing _____ (_____)

Representative of Quality Dpt. _____ (_____)